

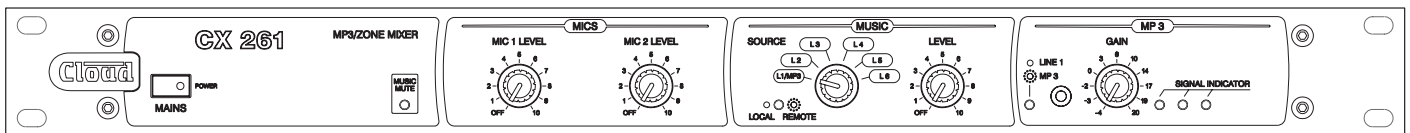

CX261 MP3/ZONE MIXER



Installation and User Guide

Contents

Contents

Safety Information	4
Safety Notes Regarding Installation	4
Conformities	4
Safety Considerations and Information	4
General Description	5
Schematic Diagram	5
Front Panel Description	6
Rear Panel Description	6
Music Inputs	7
Sensitivity and Gain Control	7
Music Source Select and Level.....	7
Remote Control of Music Source and Level	7
Mono Operation.....	7
Music Equalisation.....	7
Music Limiter	8
Music Priority	8
Front panel MP3 input	8
Microphone Inputs	9
Connectivity.....	9
Microphone Level Controls.....	9
Gain Control.....	9
Microphone Equalisation.....	9
Microphone Limiter	9
Microphone Access Input.....	9
Microphone Priorities.....	10
Microphone Over Music Priority.....	10
Mic 1 Over Mic 2 Priority	10
Use of Mic 1 input with telephone system	10
Main Outputs	11
Connectivity.....	11
Auxiliary/MOH Output	11
Source Selection.....	11
Music Mute (Fire Alarm Interface)	12
Bose® Equalisation Modules	12
Installation Instructions	12
General Notes	13
EMC Considerations.....	13
Earthing.....	13
Ventilation.....	13

Technical Specifications	14
General Specifications	15
Location of Internal Jumpers and Connectors	15
Factory Default Jumper Settings.....	16
Notes	17

Safety Information

Safety Notes Regarding Installation

- Do not expose the unit to water or moisture.
- Do not expose the unit to naked flames.
- Do not block or restrict any air vent.
- Do not operate the unit in ambient temperatures above 35 °C.
- Do not touch any part or terminal carrying the hazardous live symbol (⚡) while power is supplied to the unit.
- Do not perform any internal adjustments unless you are qualified to do so and fully understand the hazards associated with mains-operated equipment.
- The unit has no user-serviceable parts. Refer servicing to qualified service personnel.
- If the moulded plug is cut off the AC power lead for any reason, the discarded plug is a potential hazard and should be disposed of in a responsible manner.

Conformities

This product conforms to the following European EMC Standards:

BS EN 55103-1:1997

BS EN 55103-2:1997



This product has been tested for use in commercial and light industrial environments. If the unit is used in controlled EMC environments, the urban outdoors, heavy industrial environments or close to railways, transmitters, overhead power lines, etc., the performance of the unit may be degraded.

The product conforms to the following European electrical safety standard:

BS EN 60065:2002

The CX range was developed and manufactured with high quality materials and components, which can be recycled and/or reused.

Safety Considerations and Information

The unit must be earthed. Ensure that the mains power supply provides an effective earth connection using a three-wire termination.

When the mains switch is in the off position the live and neutral conductors of the mains transformer are disconnected.

Caution - High Voltages

Do not touch any part or terminal carrying the hazardous live symbol (⚡) while power is supplied to the unit.

Terminals to which the hazardous live symbol refers require installation by a qualified person.

Caution - Mains Fuse

Replace the mains fuse only with the same type and rating as marked on the rear panel.

The fuse body size is 20 mm x 5 mm.

Caution - Servicing

The unit contains no user-serviceable parts. Refer servicing to qualified service personnel. Do not perform servicing unless you are qualified to do so.

Disconnect the power cable from the unit before removing the top panel and do not make any internal adjustments with the unit switched on.

Only reassemble the unit using bolts/screws identical to the original parts.

General Description

The Cloud CX261 is a 1U rack-mounting stereo audio mixer intended for use in multi-use areas where simple control of high-quality background music needs to be combined with a flexible range of paging options.

The CX261 mixes any one of six stereo line inputs with one or two microphone inputs. Separate controls for music and mic levels are provided, and music source selection and level may be controlled remotely if wished. As well as the main output, there is a transformer-isolated mono auxiliary output which is suitable for providing a MOH (Music On Hold) output to a telephone system.

The mixer may be configured to operate with most paging systems: either mic input may be activated by voice (VOX) or short-to-ground access connections, MIC 1 may have priority over MIC 2, one line input may have priority over any other selected to facilitate connection of a digital sound store or similar device.

A front-panel 3.5 mm jack input permits easy connection of a portable MP3 player, laptop or similar, with independent level control.

A switchable isolating transformer configures MIC 1 input for direct connection to a telephone system, enabling paging messages to originate from an extension.

Bose® EQ cards may be fitted to either or both channels.

Schematic Diagram

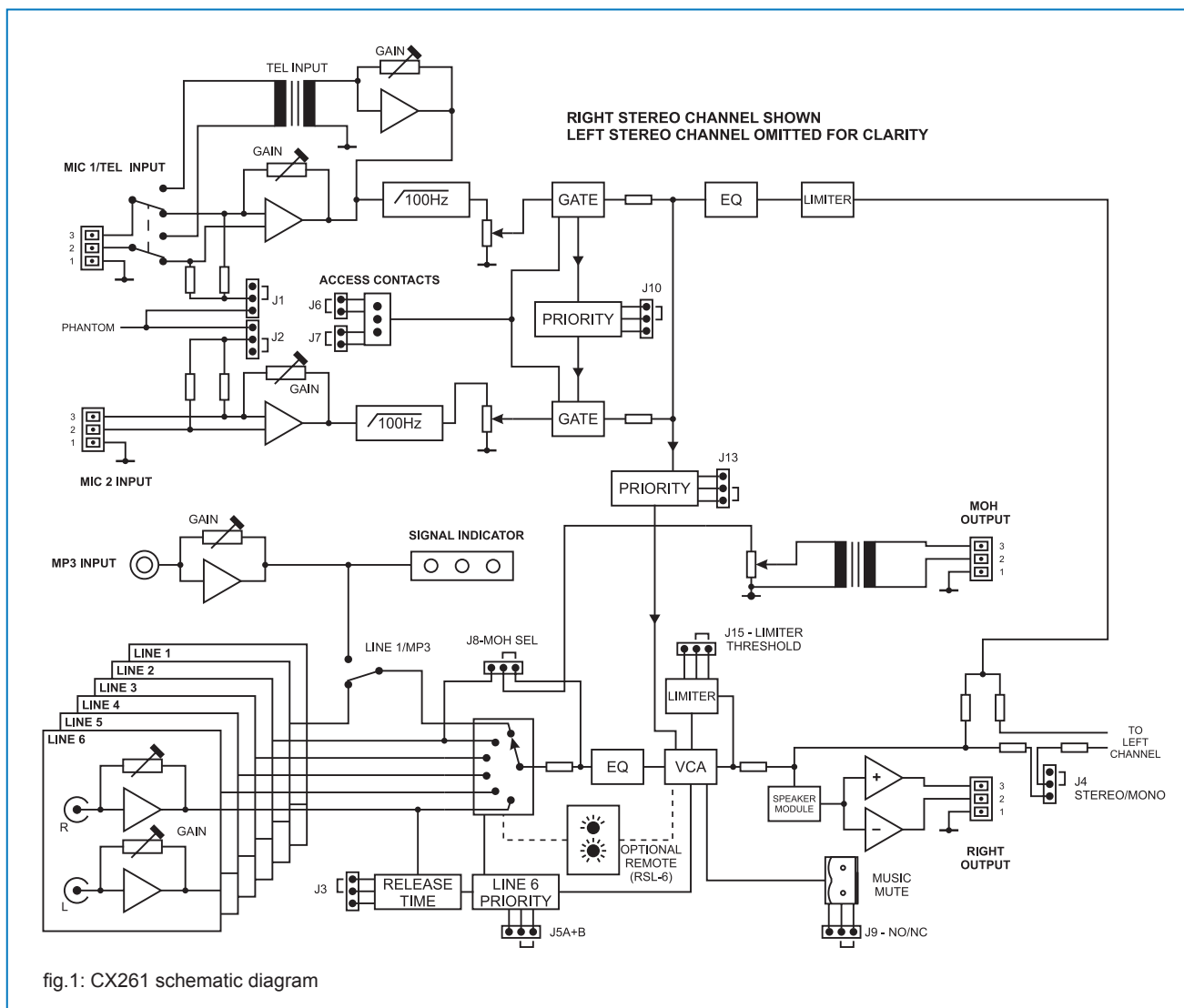

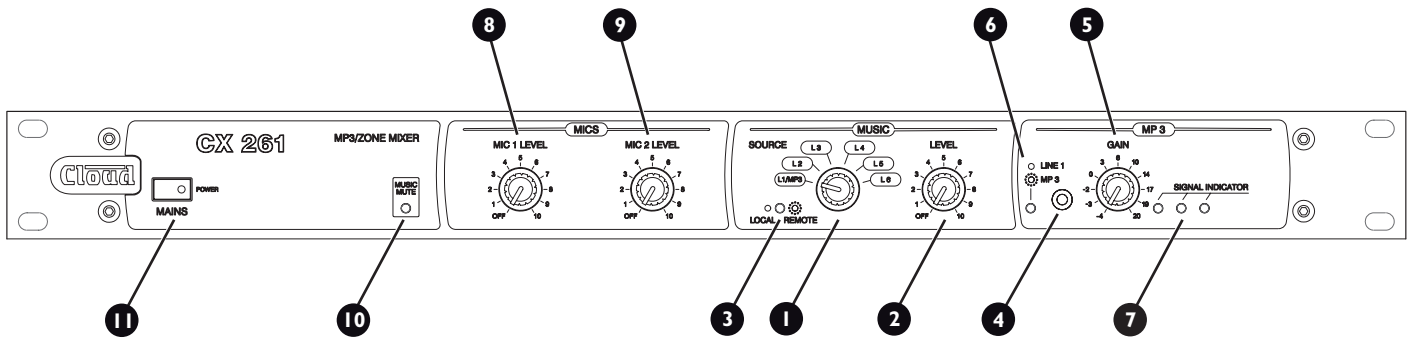

fig.2: CX261 Front panel

Front Panel Description

- 1 MUSIC SOURCE** – selects one of Music inputs L1 to L6
- 2 MUSIC LEVEL** – adjusts level of selected Music input
- 3 LOCAL/REMOTE LED** – indicates (green) when remote source selection is enabled
- 4 MP3 IN** – 3.5 mm stereo jack socket for connection of non-permanent external source
- 5 MP3 GAIN** – adjusts gain of the MP3 input
- 6 LINE 1/MP3 LED** – indicates (green) when the MP3 input is enabled
- 7 SIGNAL INDICATOR** – 3 LEDs (green/yellow/red) indicating level of MP3 input
- 8 MIC 1 LEVEL** – adjusts level of Mic input 1
- 9 MIC 2 LEVEL** – adjusts level of Mic input 2
- 10 MUSIC MUTE** – indicates (red) when external Music Mute is active
- 11 POWER** – AC mains switch with integral green LED

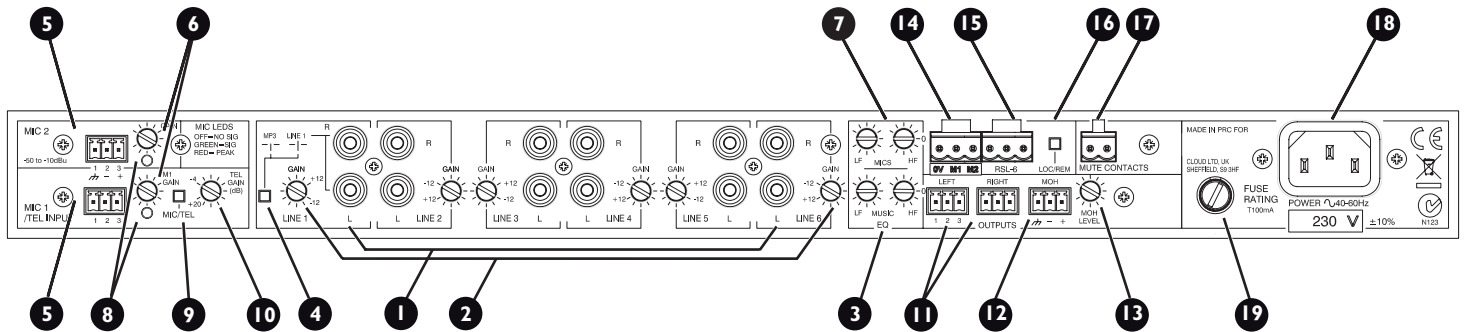

fig.3: CX261 Rear panel

Rear Panel Description

- 1 LINE 1 to LINE 6** – stereo line inputs for music sources
- 2 GAIN 1 to GAIN 6** – gain trims for each line input
- 3 LF & HF MUSIC EQ** – low and high frequency EQ adjustment for music channel
- 4 LINE 1/MP3** – replaces LINE1 RCA connectors with front panel MP3 input
- 5 MIC 1 and MIC 2** – balanced mic inputs
- 6 GAIN 1 and GAIN 2** – gain trims for each mic input
- 7 LF & HF MIC EQ** – low and high frequency EQ adjustment for mic channel
- 8 MIC LEDs** – bicolour LEDs to aid mic level adjustment
- 9 MIC/TEL** – reconfigures MIC 1 input for use with telephone system
- 10 TEL GAIN** – MIC 1 input gain adjustment in TEL mode
- 11 MAIN OUTPUTS** – balanced L & R outputs
- 12 MOH OUTPUT** – balanced auxiliary output for use with MOH systems
- 13 MOH LEVEL** – level control for MOH output
- 14 ACCESS** – external paging control inputs for MIC 1 and MIC 2
- 15 REMOTE MUSIC CONTROL** – for connection of RL-1 or RSL-6 remote control panels
- 16 LOC/REM** – disables front panel controls when remote control is in use
- 17 MUSIC MUTE** – Emergency control input for muting music source
- 18 IEC mains input**
- 19 Mains fuse**

Music Inputs

The unit has six stereo line inputs; these inputs are suitable for most music sources such as compact disc players, tape players, satellite receivers and the like. If connecting a mono music source, both L and R inputs should be wired in parallel (the exception being when using the CX261 in mono mode – see page 7, *Mono Operation*).

All inputs are unbalanced and use RCA phono sockets. The input impedance is 48 kΩ.

Line 6 input can be configured to have priority over any other music source, see *Music Priority* on page 8

Line 1's rear panel input can be disabled in favour of the front panel MP3 input, see *Front panel MP3 input* on page 8.

Sensitivity and Gain Control

All six stereo line inputs have a pre-set gain control on the rear panel adjacent to the respective input sockets. The gain control has a range of 24 dB allowing the input sensitivity to be varied from -12 dBu (200 mV_{rms}) to +12 dBu (3.1 V_{rms}).

The pre-set gain controls should be set so that all the input signals are operating at the same level and that the front panel level control has an optimum range of control.

Music Source Select and Level

Front panel controls are provided for Music source selection and level control. A six-position rotary switch selects one of Line 1 (L1) to Line 6 (L6). The first position will select either the Line 1 RCA socket or the MP3 jack socket depending on the position of the **LINE 1/MP3** switch (rear panel item 4). See *Front panel MP3 input* on page 8 for more details.

The rotary level control adjusts the level of the selected music source. Full anticlockwise rotation reduces the output level to zero.

Remote Control of Music Source and Level

The CX261 is compatible with the Cloud RSL-6 and RL-1 remote control wallplates, permitting control of music level (RL-1) or music level and source selection (RSL-6) from a remote location. The wallplates fit a standard UK single-gang back box of 25 mm depth.

Either type of plate may be connected at the rear panel **RSL-6** 3-pin 5 mm-pitch screw terminal connector (see 15 on fig. 3), using the wiring shown in figs. 4 and 5.

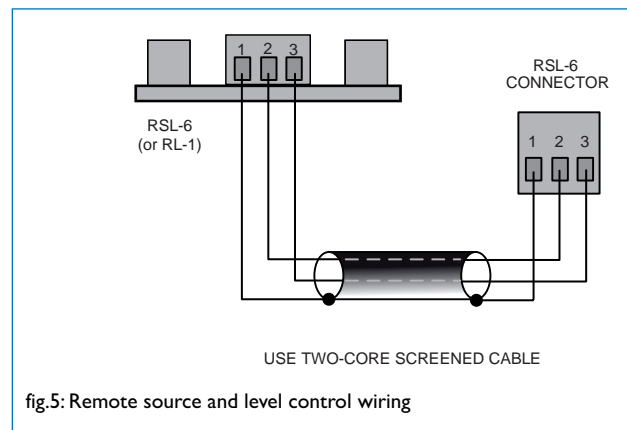
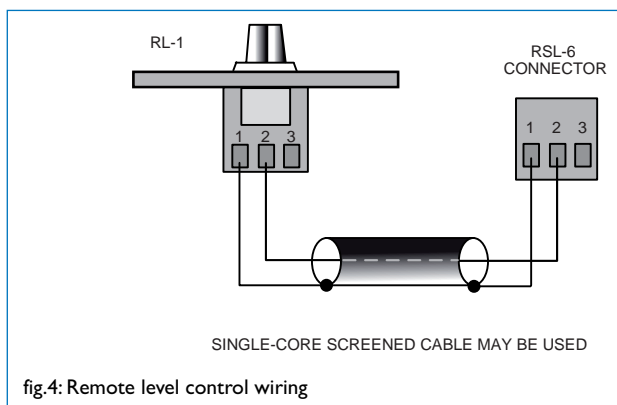

Use two-core (RSL-6 or RL-1) or single-core (RL-1 only) screened cable to connect the remote level plate (max length 100 metres).

Pressing the **LOC/REM** button adjacent to the rear panel connector activates the remote control plate and disables both the front panel level and source select controls. Confirmation of REM selection is given by a green front panel LED (3 on fig. 2). If an RL-1 is being used, the internal jumper J14 should be moved from its default 'SW' setting to 'FR', to override the disabling of the front panel source select switch. See page 15 for location of jumpers.

Versions of the remote control wallplates suitable for single gang US electrical outlet boxes are also available, designated RSL-6A and RL-1A. Front panel dimensions are 4½" x 2¾". Their operation is identical to that of the European versions.

Mono Operation

The CX261 is a 2-channel device, and is intended to be used where full stereo reproduction of music sources is desirable. If the installation does not require full stereo operation (which will generally be dictated by room layout and loudspeaker placement), mono mode should be selected. Mono mode is enabled by moving internal jumper J4 from 'STEREO' to 'MONO'.

In mono mode, the two LEFT and RIGHT main outputs will carry identical programme at the same level. Either or both may be used as wished.

Note that stereo music sources should still be connected to both L and R line inputs in the normal way. However, when mono operation is enabled, any mono music sources may be connected to either L or R only.

Music Equalisation

HF and LF equalisation for the music channel is provided via pre-set controls on the rear panel (3 on fig. 3) This permits the installer to adjust the frequency response to suit the particular acoustics and speaker types in the zone. The EQ adjustment is post the music source selection, and thus is effective on all sources.

The controls are simple shelving filters providing 10 dB of cut or boost above 10 kHz (HF control) and below 50 Hz (LF control). Note that a flat frequency response is obtained when the two controls are in their mid-positions.

Music Limiter

The music channel of the CX261 incorporates a limiter circuit to help prevent inadvertent overloading of subsequent power amplifier input stages and ultimately, the installed loudspeakers. The limiter has no external controls. If the music input gain and level controls are set correctly, the limiter action should be inaudible on normal programme material, with no compression artefacts.

The threshold of the music limiter is factory set at 0 dBu, thus signal peaks above this level will be limited. A higher threshold of +6 dBu can be set by moving internal jumper J15 (see page 15 for jumper location); this will give improved fidelity, and may be appropriate if the installer is confident about the dynamic range of the programme material.

If there is dynamics control elsewhere in the system (e.g. in the form of an external compressor/limiter or within a DSP-based unit), or if limiting is considered undesirable, the limiter may be by-passed by removing J15 from the PCB header and leaving the links open.

Music Priority

Line input 6 can be set to have priority over other music inputs. When set, the CX261 will automatically switch the music source to Line 6 when the signal level at Line 6 input exceeds -30 dBu (approx.) The input set by the source selection switch is temporarily deselected until the signal at Line 6 input stops. Then it resumes, smoothly increasing in level to its former volume. The restoration time is selectable, options are 3, 6 or 12 seconds .

This facility is useful with sources such as spot announcement players, jukeboxes, digital sound stores or similar, as audio from these sources will always automatically replace any previously selected programme for its duration.

Music Priority is set by moving internal jumpers J5A and J5B from OFF to ON. See page 15 for location of internal jumpers.

The factory default restoration time is 3 seconds. This may be too short in some cases; for example, if a jukebox was to take more than 3 seconds between the end of one track and the start of the next. In such a case, longer restoration times of 6 or 12 seconds may be set to ensure that the CX261 does not revert back to the selected music source in between tracks.

Restoration time is set by internal jumper J3. Moving the jumper position on the 3-pin header changes the restoration time from 3 s to 6 s; removing the jumper altogether sets a time of 12 s.

As well as the main outputs, Music Priority also applies to the auxiliary/MOH output when its source is set to follow the front panel selection (see page 11, *Auxiliary/MOH Output*).

Front panel MP3 input

To facilitate easy connection of digital audio devices such as portable MP3 players or laptop computers, a 3.5 mm stereo jack socket is provided on the CX261's front panel (4 on fig. 2)

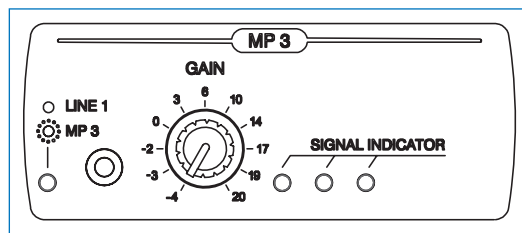

This input replaces Line input 1, and will only operate if the **MUSIC SOURCE** switch is set to **LI/MP3**. The front panel jack socket is selected instead of the LI phono sockets by setting the **LINE 1/MP3** switch on the rear panel (4 on fig. 3) to **MP3**. A green LED on the front panel (6 on fig. 2) illuminates to confirm the selection. When the MP3 input is selected, the music source connected to LI will no longer be available.

To allow for the wide range of signal levels which may be encountered from portable audio devices, the MP3 input is provided with its own level control and signal level LEDs (5 and 7 respectively on fig. 2). The range of sensitivity adjustment is from -20 dBu (with the control fully clockwise, at "20") to +4 dBu (with the control fully anticlockwise, at "-4").

Three LEDs (7 on fig. 2) are fitted to the front panel to aid level adjustment. The LEDs illuminate at the levels shown in the table:

LED	LEVEL
Green	-21 dBu
Yellow	-6 dBu
Red	+1 dBu

With an MP3 player (or other source) connected to the MP3 input and playing, and the MP3 input selected, the level control should be adjusted so that the green and yellow LEDs are on more or less continuously and the red LED only on during the louder passages.

Microphone Inputs

Two microphone inputs are provided; the microphone pre-amplifiers are an electronically balanced, transformer-less design configured for optimum low noise performance. The input impedance is greater than 2 k Ω and is suitable for microphones in the 200 Ω to 600 Ω range.

15V phantom power is available on either or both mic inputs for powering condenser mics, and is activated by setting internal jumpers J1 and J2 (for mic inputs 1 and 2 respectively) to the ON position. See page 15 for location of jumpers. Care should be taken to ensure that phantom power is activated only when the microphone connected to the input requires external phantom power; damage to the microphone may result otherwise.

Mic 1 input may be configured for use with a telephone system. See page 10 for more details.

Connectivity

Inputs are via 3-pin 3.5 mm-pitch screw terminal connectors on the rear panel (5 on fig. 3). Connect microphones as shown below. Note that if using an unbalanced microphone, pins 1 and 2 should be connected together.

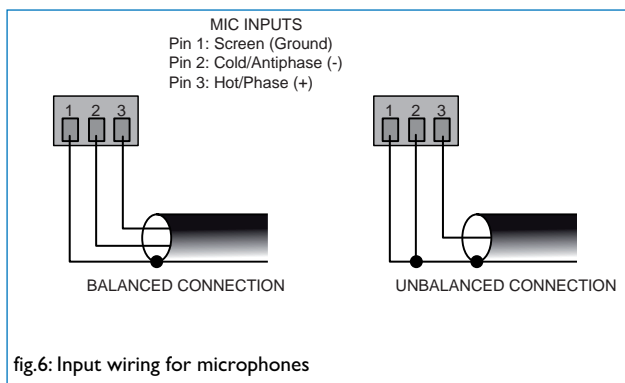

Microphone Level Controls

A separate front panel level control (8 and 9 on fig. 2) is provided for each mic input and these provide the user with a convenient means of adjusting the audio level of the microphones. The mic levels are unaffected by the operation of the music level, music mute and remote music level controls (if fitted).

Gain Control

A preset mic gain control is provided adjacent to each input connector (6 on fig. 3); this adjusts the mic pre-amp gain in the range 10 dB to 50 dB. A high overload margin is maintained at all gain settings, and a limiter circuit is always active (see Microphone Limiter on this page). Nevertheless, the gain controls should be set during installation so that microphone distortion does not occur even when the front panel **MIC LEVEL** controls are fully clockwise.

Microphone Equalisation

The microphone input stages each incorporate a fixed high pass filter. The filter attenuates signals below 100 Hz, which helps to reduce the effects of microphone handling noise. The mic inputs are then summed together and mixed

with the music channel (priority settings permitting) via an adjustable EQ section.

The two pre-set EQ controls (7 on fig. 3) are on the rear panel adjacent to the music EQ controls; the LF and HF controls provide ± 10 dB of adjustment below 100 Hz and above 5 kHz respectively. After installation, some test announcements should be made, ideally by the people who will normally make them. The Mic EQ should be adjusted if necessary to maximise voice clarity.

Microphone Limiter

The microphone channel incorporates a limiter circuit to prevent amplifier and speaker overloading and also to help maintain more constant speech volume when the system is used by different announcers. The limiter is set to restrict the mic signals to a nominal 0 dBu, and if the mic gain and level are set correctly, should be inaudible in operation on normal speech. There are no internal or external controls.

Microphone Access Input

Access control for both microphone inputs is provided to allow the CX261 to be interfaced to single-zone paging mics such as the Cloud PMI. The access contacts work on the short-to-ground system, which is compatible with the majority of paging microphones.

The CX261 is shipped with the access control input disabled for both microphone inputs. This allows immediate use with standard microphones not fitted with PTT (Press-to-Talk) switches. If external access control is required, the internal jumpers J6 (Mic 1) and J7 (Mic 2) must first be removed. See page 15 for location of the jumpers.

The access control input is a 3-pin 5 mm-pitch screw terminal connector on the rear panel (14 on fig. 3). Mic input 1 becomes active when **M1** is connected to **0V**; Mic input 2 becomes active when **M2** is connected to **0V**.

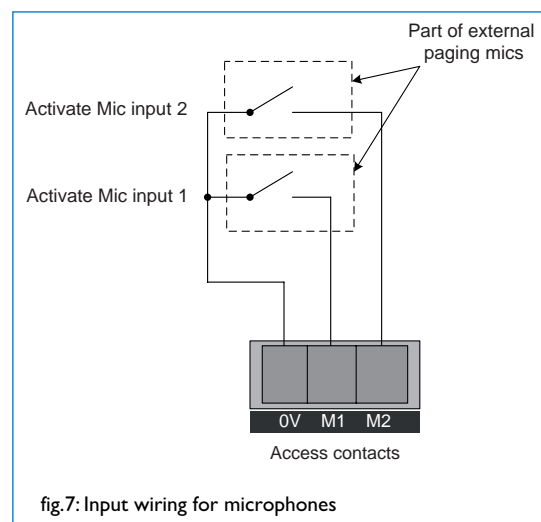

See also the following section “Microphone Priority” for further information on the use of the CX261 with paging microphones.

Microphone Priorities

The microphone inputs on the CX261 may be configured so that when they are in use, they take priority over the music programme; additionally, Mic input 1 may be set to take priority over Mic input 2.

There are two methods of triggering the microphone priority circuitry: signal detection (AVO) or via the zone access contacts on the rear panel (ACC). The choice is made by internal jumpers J11 (Mic input 1) and J12 (Mic input 2); note the two mic inputs may be set differently if wished. See page 15 for location of the jumpers.

The factory default is for both mic inputs to be set to AVO (Automatic Voice-Over). In this mode, the priority circuit is triggered by the presence of a signal at the microphone input. The alternative ACC jumper setting triggers the priority by contact closure when the access contacts are enabled. ACC priority should only be selected when a suitable paging microphone is used.

Note that priority detection may be disabled by removing J11/J12. In this state, the mic channels will still operate normally, but music programme will remain at full level, and the two mic inputs will be mixed together if both are active simultaneously.

Microphone Over Music Priority

The priority circuitry is configured at the factory to duck the music programme (reduce its level) when an announcement is made. At the completion of the announcement, after a delay of 1 second, the music ramps back up to its original level over a period of 1 second. The ducking action can be overridden by moving internal jumper J13 from the ON position to the OFF. See page 15 for location of internal jumpers.

Mic 1 Over Mic 2 Priority

In installations where both mic inputs are being used, it is possible for announcements to clash if the mics are active simultaneously. By default, the CX261 allows both microphones to access the system simultaneously. **Mic 1** may be given priority over **Mic 2** by moving internal jumper J10 from the OFF position to the ON. (See page 15 for location of internal jumpers.) Then, if **Mic 1** is already making an announcement, **Mic 2** will not be able to access the system. Also, if **Mic 2** is making an announcement and **Mic 1** then becomes active, **Mic 2**'s announcement will be curtailed and **Mic 1**'s will take over.

Use of Mic 1 input with telephone system

Mic 1 input on the CX261 may be reconfigured to accept an audio input directly from a compatible telephone system. This permits announcements to be made from some (or any) internal telephone extensions in a building. Not all telephone systems are suitable for this application, and the system documentation should be consulted in detail to ensure compatibility.

The MIC/TEL button on the rear panel (9 on fig. 3) should be in the **TEL** position (in) for this application. This inserts a transformer in series with the input connector to provide

full electrical isolation from the telephone system, together with an independent gain control stage.

The audio (or "paging") output of the phone system should be connected to the MIC 1 input in the normal way. The impedance of the telephone input is 600 Ω; this should be suitable for the majority of telephone systems. If the telephone system requires a high input impedance, internal jumper J16 may be removed to provide an input impedance of 48 kΩ. See page 15 for location of internal jumpers.

The **TEL GAIN** preset gain control (10 on fig. 3) should be adjusted with a test call from the telephone system. Note that the front panel **MIC 1 LEVEL** control is still operational.

Main Outputs

The main LEFT and RIGHT outputs on the CX261 are electronically balanced and can operate into loads down to 1.2 k Ω . The nominal output level is 0 dBu (775 mV_{rms}) but the mixer can drive a maximum output level of +20 dBu (7.75 V_{rms}).

Connectivity

The outputs are on rear panel 3-pin 3.5 mm-pitch screw terminal connectors (11 on fig. 3). For balanced connections, 2-core screened cable should be used. Connect as shown below.

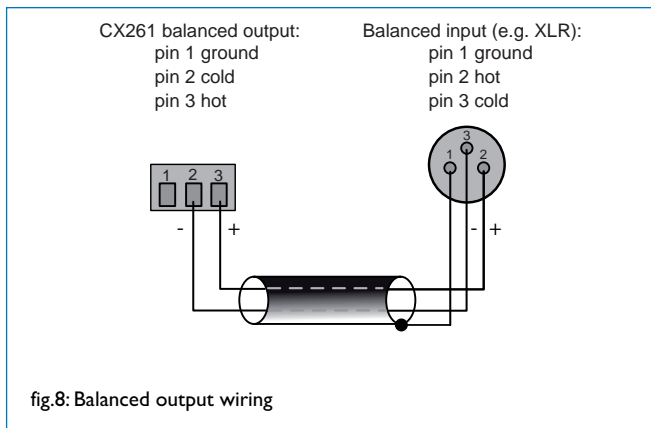

Unbalanced connection may be used if necessary, but its use is recommended only between pieces of equipment in the same rack. Unbalanced signals should not be run over long distances. An unbalanced output connection should be wired as shown below:

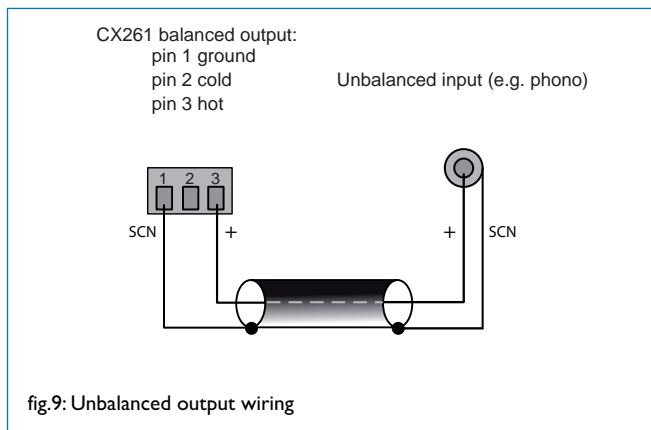

Note that pin 2 of the output connector is not used.

Auxiliary/MOH Output

The MOH (Music On Hold), or auxiliary output, provides a transformer-isolated L+R mono sum of the music channel. This is intended to provide a continuous music feed for use with a telephone system. If it is not required for this, it may be used as an auxiliary mono output for another suitable purpose. However, it should be noted that a fixed LF filter reduces bass frequencies at this output to optimise it for use with telephone systems. The microphone inputs are not mixed into this output, so that internal paging announcements are not heard by telephone callers. This fact should be borne in mind if the output is used for some other purpose.

The output is a 3-pin 3.5 mm-pitch screw terminal connector on the rear panel (12 on fig. 3). The output level is -6 dBu (nominal) and is suitable for driving 600 Ω loads.

The output is transformer-coupled to provide full galvanic isolation from a telephone system. Because of this, pin 2 (cold/-) must always be connected. The wiring convention shown in fig. 8 for connection to a balanced input may be followed, but if wiring to an unbalanced input, the convention shown below should be followed:

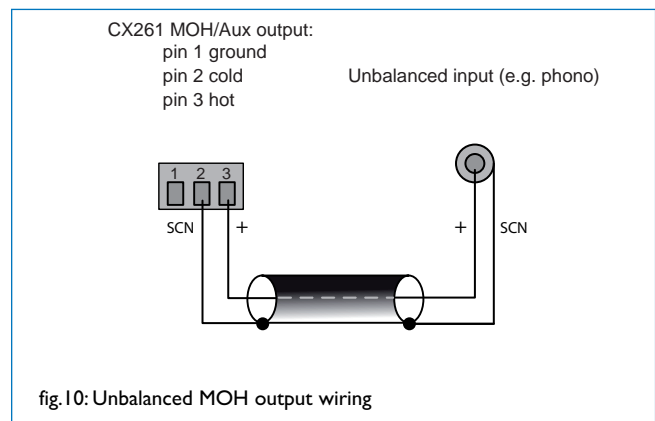

The signal level at the auxiliary/MOH output can be set independently, via the rear panel preset **MOH LEVEL** control (13 on fig. 3.) The output level is zero with the control fully anticlockwise. Note that the signal at this output is NOT altered by the front panel **MUSIC LEVEL** control or the rear panel **MUSIC EQ** preset adjustments.

Source Selection

If the output is to be used as an auxiliary mono feed, it will generally need to follow the normal music source selection. This is the factory default configuration. If Music Priority is enabled (see page 8, *Music Priority*), the auxiliary/MOH output will switch to Line 6 along with the main outputs if the input becomes active.

However, when in use as an MOH source, it is generally more desirable for the music source (typically a CD jukebox or music server) to remain constant, and not vary with the front panel **MUSIC SOURCE** control. For this purpose, the source for the auxiliary/MOH output can be altered, by moving internal jumper J8 from **SEL** to **LINE 2**. The music source that is intended to provide the Music On Hold programme should be connected to **LINE 2**. See page 15 for location of the internal jumper.

In either case no microphone signals are present at the auxiliary/MOH output, thus announcements made via the microphone inputs do NOT interrupt music programme at this output, regardless of any priority settings.

Music Mute (Fire Alarm Interface)

In some installations (such as licensed premises or retail outlets within a shopping mall), there may be a local authority or fire service requirement to mute the music signals from a fire alarm control panel when an alarm condition arises. The CX261 includes a facility to mute the music programme only (i.e., mic inputs are still active), via the Music Mute input. This is a 2-pin 5 mm-pitch screw terminal connector on the rear panel. The input is usually connected to a pair of isolated relay contacts activated by the fire system.

Note that the Music Mute function only mutes the CX261's main outputs; the auxiliary/MOH output remains active.

Activation of the Music Mute is often via a relay mounted close to the CX261 and its associated amplifiers, powered by the fire alarm control panel. Other arrangements may exist depending on the design of the fire control system and the fire alarm installation company should be consulted when making the connection. The CX261 will mute on either a contact closure at the Music Mute input (NO) or an open circuit (NC). Selection of NO or NC operation is made with internal jumper J9. NO is the factory default. See page 15 for details of jumper location. The diagram below shows the two connections.

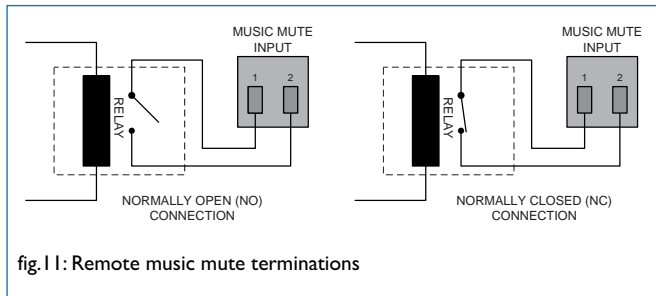

fig. 11: Remote music mute terminations

Bose® Equalisation Modules

The CX261 is compatible with single channel Bose® Series II equalisation modules. EQ modules are available to suit the following Bose® loudspeakers:

- Panaray® MA12
- Panaray® 402-II, 502B and 502BEX
- Panaray® LT Series:
Models 3302, 4402, 9402 and 9702.

Modules to suit other models are available – please enquire.

Installation Instructions

Refer to the PCB layout diagram (see page 15) for the location of the Bose® EQ module connectors. Note that there are two connectors, one per main output (LEFT and RIGHT). There is no provision for fitting an equalisation module to the auxiliary/MOH output.

To install an EQ module, proceed as follows:

- Switch off the power and isolate the unit from the mains.
- Remove the top panel.
- Plug the Bose® equalisation module onto its connector; note that the connector has two notches on one side which engage with lugs on the module's mating connector to ensure correct orientation.
- Replace the top panel.

General Notes

EMC Considerations

The CX261 fully conforms to the relevant electromagnetic compatibility (EMC) standards and is technically well behaved. You should experience no problems interfacing units to other items of equipment and under normal circumstances, no special precautions need to be taken.

If the unit is to be used in close proximity to potential sources of HF disturbance such as high power communication transmitters, radar stations and the like, it is suggested that input signal leads be kept as short as possible.

Always use balanced interconnections wherever possible. If the CX261 is mounted in a 19" rack, do not locate the unit in close proximity to a powerful amplifier of any kind, which may radiate a strong magnetic field from the power transformer.

Earthing

When several mains powered units are connected together via their signal cables, there is a risk of one or more earth loops which may cause an audible hum on the system even with the gain controls set to minimum.

The 0V rail of the CX261 is directly coupled to the chassis ground. No interconnection problems should be encountered, but if there is any hum or other extraneous noise when source equipment is connected, the situation can generally be remedied by observing the following guidelines:

- Always connect the microphone inputs using balanced connections wherever possible, with the cable screen only connected at the mixer input.
- Always connect the mixer outputs using balanced connections wherever possible, with the cable screen only connected at the destination (normally an amplifier input).
- Use audio isolating transformers (readily available from trade suppliers) at the inputs and/or outputs if necessary. These will ensure that the mixer is electrically isolated from other equipment.
- Both signal source units and amplifiers should be located as close as possible to the mixer and the metal housing of the various units should not be electrically connected together through the equipment rack. If this is a problem, rack isolating kits are available from specialist hardware suppliers. If the problem persists, try to connect all interconnected units, including power amplifiers to a common power source to ensure a common ground is provided.

Ventilation

The CX261 generates very little heat in normal operation and is cooled by natural convection. However, note that there are ventilation holes on the bottom cover, and these should never be covered or obstructed. Installation in an equipment rack is always recommended, but care should be taken not to mount the unit immediately above another item of equipment, as this will block the ventilation holes. If the unit is to be used free-standing, stick-on rubber feet should be attached to the bottom plate to ensure clearance from the surface the unit sits on.

Technical Specifications

Line Inputs

	Specifications
Frequency Response	20 Hz-20 kHz, ± 0.5 dB
Distortion	<0.05% typical, 1 kHz
Sensitivity	0.775 V (0 dBu), ± 12 dB
Input Gain Control	24 dB range
Input Impedance	48 k Ω
Headroom	>20 dB
Noise (rms)	-88 dB rms typical, 20 Hz-22 kHz
Equalisation	LF: ± 10 dB 50 Hz, HF: ± 10 dB 10 kHz

MP3 Input

	Specifications
Frequency Response	20 Hz – 20 kHz, ± 0.5 dB
Distortion	<0.05%, 1 kHz
Sensitivity	-20 dBu to +4 dBu
Gain Adjustment	24 dB

Microphone Inputs

	Specifications
Frequency Response	100 Hz -3dB (filter), 20 kHz ± 0.5 dB
Distortion	20 Hz - 22 kHz, <0.05%
Gain Range	40 dB
Sensitivity	-10 dBu to -50 dBu
Input Impedance	>2 k Ω (balanced)
Common Mode Rejection	1 kHz, >70dB
Headroom	>20 dB
Noise	<-125 dB EIN, 20 Hz-22 kHz, 150 Ω
Equalisation	LF: ± 10 dB @ 100 Hz, HF: ± 10 dB @ 5 kHz

Tel Input

	Specifications
Frequency Response	-3 dB @ 100 Hz (filter); <-0.5 dB @ 20 kHz
Distortion	<0.05%, 200 Hz – 20 kHz
Sensitivity	-20 dBu to + 4 dBu
Gain Adjustment	24 dB

Outputs

	Main	Aux/MOH
Nominal Output Level	0 dBu	-6 dBu
Minimum Load Impedance	1.2 k Ω	600 Ω
Maximum Output Level	+20 dBu	0 dBu

General Specifications

	Specifications
Power Input	230 V \pm 10%
Fuse Rating	T100 mA 230V
Fuse Type	20 mm x 5 mm 250V
Dimensions (mm, W x H x D)	482.6 x 44 (1U) x 152.5
Weight (kg)	2.15

Location of Internal Jumpers and Connectors.

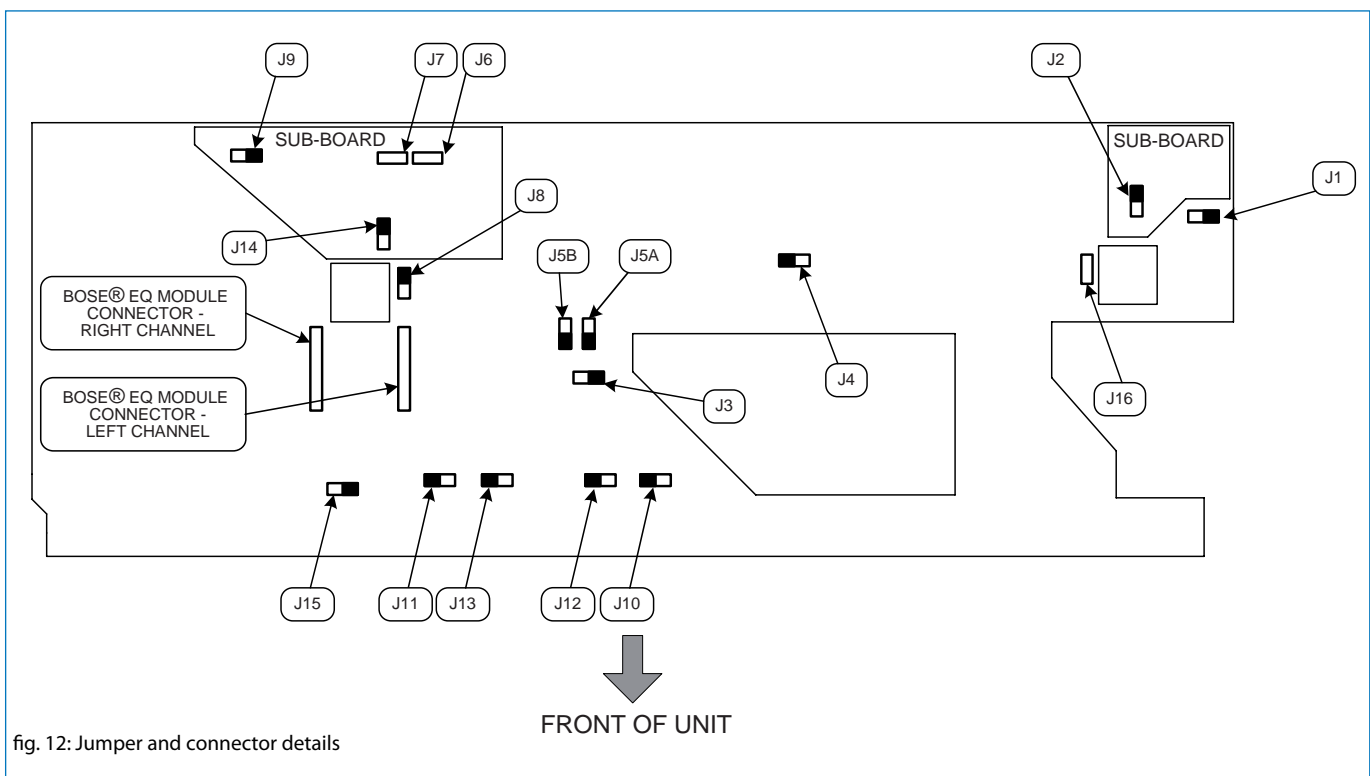

fig. 12: Jumper and connector details

Factory Default Jumper Settings

JUMPER	FUNCTION	SETTINGS	DEFAULT
J1	MIC 1 phantom power	OFF = no phantom power	OFF
		ON = +15 V phantom power	
J2	MIC 2 phantom power	OFF = no phantom power	OFF
		ON = +15 V phantom power	
J3	L6 priority release time	3S = 3 secs release time	3S
		6S = 6 secs release time	
		OFF = 12 secs release time	
J4	Mono/stereo operation	MONO = L&R music inputs are summed	STEREO
		STEREO = normal operation	
J5 (A&B)*	L6 priority (left & right)	OFF = no priority – normal operation	OFF
		ON = L6 has priority when active	
J6	MIC 1 access bypass	JUMPER = MIC 1 always active	JUMPER
		NO JUMPER – use M1 access port to activate MIC 1	
J7	MIC 2 access bypass	JUMPER = MIC 2 always active	JUMPER
		NO JUMPER – use M2 access port to activate MIC 2	
J8	MOH source select	SEL = Aux/MOH output follows music source selection	SEL
		L2 = Aux/MOH output is always LINE 2	
J9	Music Mute configuration	NO = external contact closure required for mute	NO
		NC = external contact opening required for mute	
J10	MIC 1 over MIC 2 priority	OFF = Mics have equal priority	OFF
		ON = MIC 1 has priority over MIC 2	
J11	MIC 1 priority trigger	AVO = MIC 1 priority triggered by announcement (VOX)	AVO
		ACC = MIC 1 priority triggered by contact closure	
J12	MIC 2 priority trigger	AVO = MIC 2 priority triggered by announcement (VOX)	AVO
		ACC = MIC 2 priority triggered by contact closure	
J13	Mic over music priority	OFF = music remains during announcement	ON
		ON = music ducks during announcement	
J14	REM mode source selection	FR = permits front panel source selection in REM mode	SW
		SW = front panel source selection disabled in REM mode	
J15	Music limiter threshold	0dBu = music level limited to 0 dBu	0dBu
		+6dBu = music level limited to +6 dBu	
J16	TEL input impedance	JUMPER = $Z_{in} = 600 \Omega$	JUMPER
		NO JUMPER = $Z_{in} = 48 k\Omega$	

* J5A and J5B must always have the same setting.

Notes

Bose® is a registered trademark of The Bose Corporation.

In the interest of continuing improvements Cloud Electronics Limited reserves
the right to alter specifications without prior notice.



Cloud Electronics Limited
140 Staniforth Road
Sheffield S9 3HF
England
Tel: +44 (0)114 244 7051
Fax: +44 (0)114 242 5462
email: info@cloud.co.uk
web: www.cloud.co.uk