

SELECON

PRODUCT DATA SHEET



ACCLAIM

FRESNEL

A general purpose fresnel for theatre, small studio and display lighting. The adjustable cone of light has a soft edge, easily blended with adjacent beams to provide even illumination.

The Acclaim Fresnel offers efficiency, strength and performance using a 110mm diameter lens.

FEATURES

- Up to 40% more light output than comparative fresnel luminaires.
- A wide range of beam angles from 6°-60°.
- Adjustable yoke balance point.
- 'Swing-down' door for easy access to lamp or cleaning. Isolates the mains supply when opened.
- Captive lamp/ reflector focus system moves on brass bearing provides smooth focus movement.
- Rear grab-handle, doubles as handy cable storage.
- Constructed of pressure die-castings and aluminium extrusion.
- Fully tested and compliant to CE standards.

PHYSICAL DATA

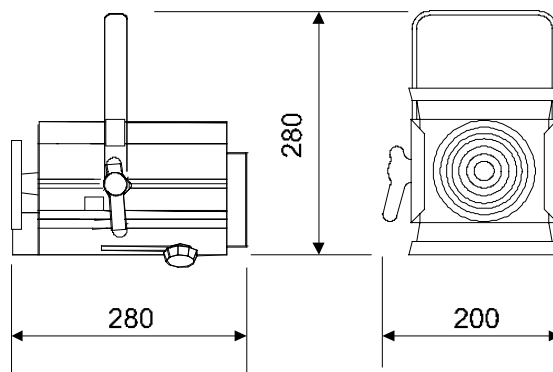

Weight: 2.8 Kg
Packed Weight: 3.2Kg
Carton Size: 420 x 225 x 175
Carton Size Cubic: 0.016
Colour Frame Size: 125mm x 125mm
Included: 1 x colour frame, 1 x M12 nut & bolt set, instruction leaflet.

PHOTOMETRIC DATA

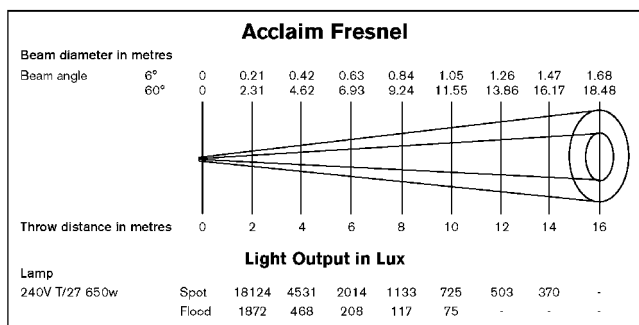

Tests conducted using a standard T27, 650W, 240V, 15,000 lumens lamp.

LAMPS: 220V-240V

500W		
T/25, T/18	11,000 lumens	400 hours average life
650W		
T/26, T/27	14,500 lumens	600 hours average life

ORDER CODES & ACCESSORIES

Acclaim Fresnel	12ACFMS
Barndoor	20BDMF
Lens Safety Mesh	15ACSM
Suspension Hookclamp	20HC
Safety Bond	20SC

Selecon reserves the right to change the specifications without notice (09/04)

SELECON, THE ONLY LUMINAIRE MANUFACTURER TO OFFER A LIMITED THREE YEAR WARRANTY ON ENTERTAINMENT PRODUCTS: www.seleconlight.com/english/support/warranty.html

© 2004 Selecon New Zealand Limited. All Rights Reserved.