

70

2500
2400

240

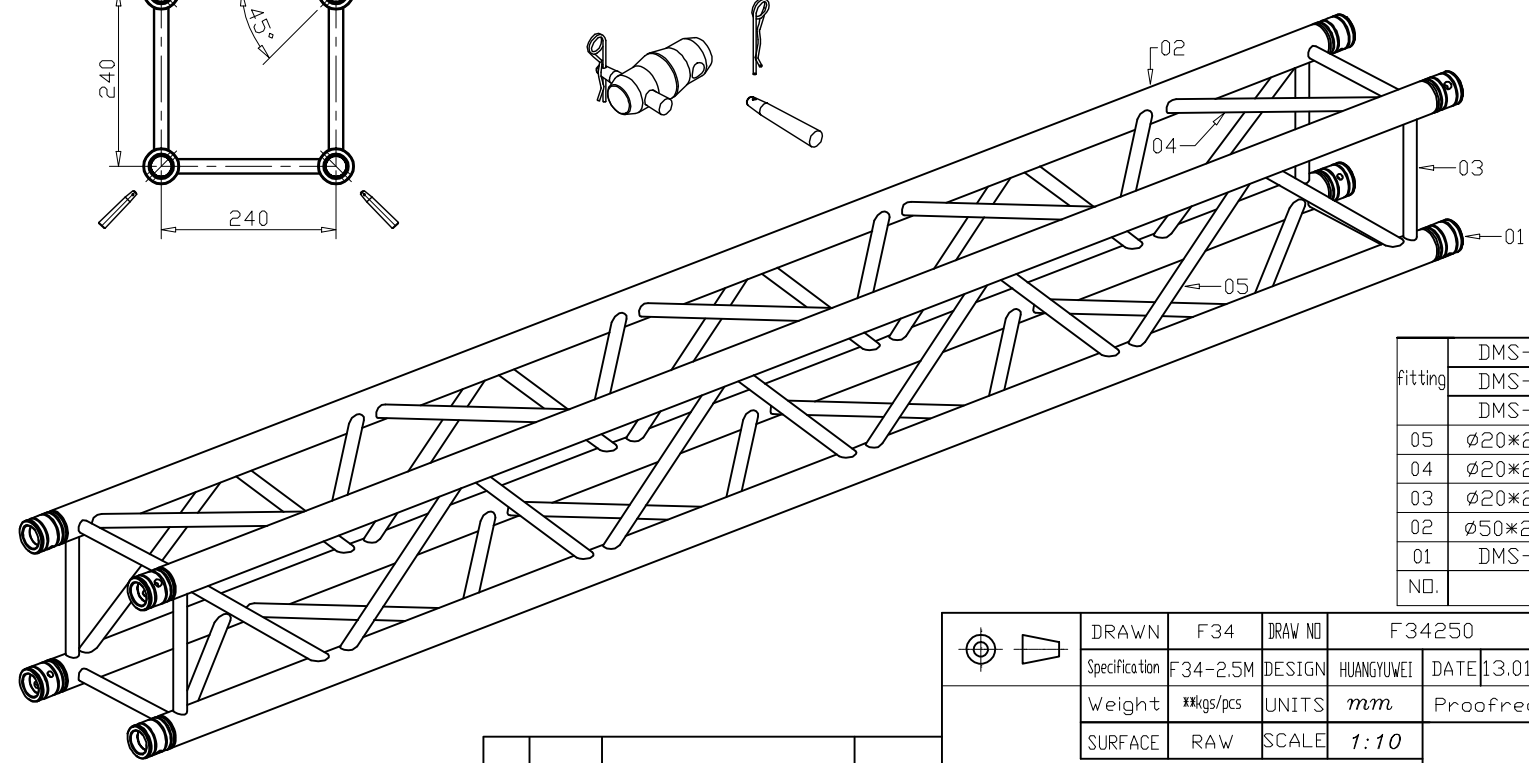
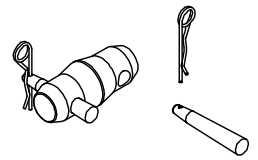
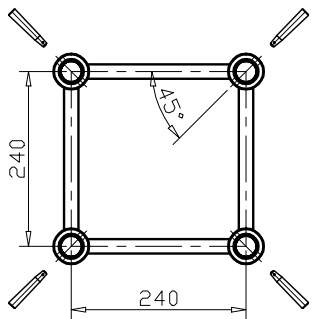

fitting	DMS-01-1	steel	ZP	8
	DMS-01-4	S45C	ZP	8
	DMS-01-3	#2011	T6	4
05	∅20*2.0t*295.2mm	#6082	T6	28
04	∅20*2.0t*325.7mm	#6082	T6	8
03	∅20*2.0t*189.5mm	#6082	T6	8
02	∅50*2.0t*2400mm	#6082	T6	4
01	DMS-01-2R	#6082	T6	8
NO.	SPEC.	MATERIAL	FIN.	QTY.

	DRAWN	F34	DRAW NO	F34250		2D/3D	edition	1
	Specification	F34-2.5M	DESIGN	HUANGYUWEI	DATE	13.01.28	CHECKED	APPROVED
	Weight	**kgs/pcs	UNITS	mm	Proofread			
	SURFACE	RAW	SCALE	1:10				

MARK	NAME	RETRIEVE CONTENTS	DATE

