

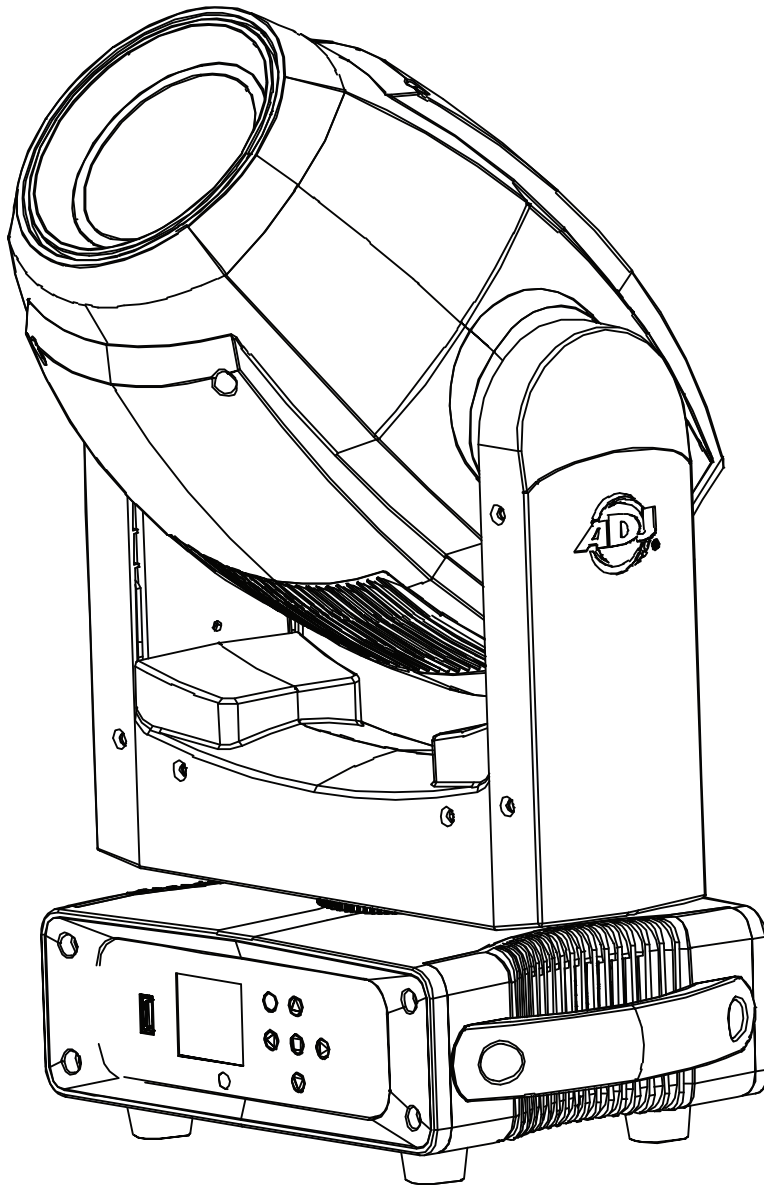

# FOCUS SPOT 4Z



***User Instructions***

©2018 ADJ Products, LLC all rights reserved. Information, specifications, diagrams, images, and instructions herein are subject to change without notice. ADJ Products, LLC logo and identifying product names and numbers herein are trademarks of ADJ Products, LLC. Copyright protection claimed includes all forms and matters of copyrightable materials and information now allowed by statutory or judicial law or hereinafter granted. Product names used in this document may be trademarks or registered trademarks of their respective companies and are hereby acknowledged. All non-ADJ Products, LLC brands and product names are trademarks or registered trademarks of their respective companies.

**ADJ Products, LLC** and all affiliated companies hereby disclaim any and all liabilities for property, equipment, building, and electrical damages, injuries to any persons, and direct or indirect economic loss associated with the use or reliance of any information contained within this document, and/or as a result of the improper, unsafe, insufficient and negligent assembly, installation, rigging, and operation of this product.

#### **FCC STATEMENT**

This device complies with Part 15 of the FCC Rules. Operation is subject to the following two conditions: (1) this device may not cause harmful interference, and (2) this device must accept any interference received, including interference that may cause undesired operation.

#### **FCC RADIO FREQUENCY INTERFERENCE WARNINGS & INSTRUCTIONS**

This product has been tested and found to comply with the limits as per Part 15 of the FCC Rules. These limits are designed to provide reasonable protection against harmful interference in a residential installation. This device uses and can radiate radio frequency energy and, if not installed and used in accordance with the included instructions, may cause harmful interference to radio communications. However, there is no guarantee that interference will not occur in a particular installation. If this device does cause harmful interference to radio or television reception, which can be determined by turning the device off and on, the user is encouraged to try to correct the interference by one or more of the following methods:

- Reorient or relocate the device.
- Increase the separation between the device and the receiver.
- Connect the device to an electrical outlet on a circuit different from which the radio receiver is connected.
- Consult the dealer or an experienced radio/TV technician for help.

## **DOCUMENT VERSION**

Please check [www.adj.com](http://www.adj.com) for the latest revision/update of this guide.

<b>Date</b>	<b>Document Version</b>	<b>Software Version <math>\geq</math></b>	<b>DMX Channel Mode</b>	<b>Notes</b>
12/27/18	1	1.04	16/18/22	Initial Release

#### **Europe Energy Saving Notice**

Energy Saving Matters (EuP 2009/125/EC)

Saving electric energy is a key to help protecting the environment. Please turn off all electrical products when they are not in use. To avoid power consumption in idle mode, disconnect all electrical equipment from power when not in use. Thank you!

Introduction	3
Features   Warranty Registration   Installation	4
Safety Precautions	5
Installation	7
Overview	9
DMX Set Up	10
DMX Addressing	12
DMX Channel Modes & Values	13
System Menu	16
Operating Instructions	18
Master-Slave Set Up	27
Dimmer Curve Chart	28
Dimensional Drawings	29
Gobo Replacement & Gobos	30
Fuse Replacement   Multiple Unit Power Linking	31
Trouble Shooting   Cleaning	21
Warranty	32
Technical Specifications	33

**Unpacking:** Thank you for purchasing the Focus Spot 4Z by ADJ Products, LLC. Every unit has been thoroughly tested and has been shipped in perfect operating condition. Carefully check the shipping carton for damage that may have occurred during shipping. If the carton appears to be damaged, carefully inspect your fixture for any damage and be sure all accessories necessary to operate the unit has arrived intact. In the case damage has been found or parts are missing, please contact our toll free customer support number for further instructions. Do not return this unit to your dealer without first contacting customer support.

**Introduction:** The Focus Spot 4Z is a DMX intelligent, moving head, LED fixture. This fixture can be used in a stand alone mode or connected in a Master/Slave configuration. The fixture comes equipped with motorized focus and zoom, 6 different dimming options. The Focus Spot 4Z has 3 DMX channel modes; 16, 18, & 22. ***This product is intended to be used by professionally trained personnel only and is not suitable for private use.***

**Customer Support:** Contact ADJ Service for any product related service and support needs. Also visit [forums.adj.com](http://forums.adj.com) with questions, comments or suggestions.

**Parts:** To purchase parts online visit <http://parts.americandj.com>

**ADJ SERVICE USA - Monday - Friday 8:00am to 4:30pm PST**

**Voice: 800-322-6337 | Fax: 323-832-2941 | [support@adj.com](mailto:support@adj.com)**

**ADJ SERVICE EUROPE - Monday - Friday 08:30 to 17:00 CET**

**Voice: +31 45 546 85 60 | Fax: +31 45 546 85 96 | [support@adj.eu](mailto:support@adj.eu)**

#### **ADJ PRODUCTS LLC USA**

6122 S. Eastern Ave. Los Angeles, CA. 90040

323-582-2650 | Fax 323-532-2941 | [www.adj.com](http://www.adj.com) | [info@adj.com](mailto:info@adj.com)

#### **ADJ SUPPLY Europe B.V**

Junostraat 2 6468 EW Kerkrade, The Netherlands

+31 (0)45 546 85 00 | Fax +31 45 546 85 99

[www.adj.eu](http://www.adj.eu) | [info@americandj.eu](mailto:info@americandj.eu)

#### **ADJ PRODUCTS GROUP Mexico**

AV Santa Ana 30 Parque Industrial Lerma, Lerma, Mexico 52000

+52 (728) 282-7070

**Caution!** There are no user serviceable parts inside this unit. Do not attempt any repairs yourself, doing so will void your manufacturer's warranty. In the unlikely event your unit may require service please contact ADJ Products, LLC.

***PLEASE recycle the shipping carton when ever possible.***

## Focus Spot 4Z

## Features

- Individual Color and Gobo Wheels
- 8 Colors + White
- 6 Rotating Replaceable Gobos + Open
- Electronic Dimming 0-100%
- DMX-512 protocol
- 3-Pin DMX Connections
- 3 DMX Channel Modes: 16/18/22
- Multiple Unit Power Linking (See page 32)

Included:

1 x powerCON Cable

2 x Safety Cables

## Focus Spot 4Z

## Warranty Registration

The Focus Spot 4Z carries a 2 year limited warranty. Please fill out the enclosed warranty card to validate your purchase. All returned service items whether under warranty or not, must be freight pre-paid and accompany a return authorization (R.A.) number. The R.A. number must be clearly written on the outside of the return package. A brief description of the problem as well as the R.A. number must also be written down on a piece of paper included in the shipping carton. If the unit is under warranty, you must provide a copy of your proof of purchase invoice. You may obtain a R.A. number by contacting our customer support team on our customer support number. All packages returned to the service department not displaying a R.A. number on the outside of the package will be returned to the shipper.

## Focus Spot 4Z

## Installation

The unit should be mounted using a mounting clamp (not provided), affixing it to the mounting bracket that is provided with the unit. Always ensure that the unit is firmly fixed to avoid vibration and slipping while operating. Always ensure that the structure to which you are attaching the unit is secure and is able to support a weight of 10 times the unit's weight. **ALWAYS** use safety cables that can hold 12 times the weight of the unit when installing the fixture.

This equipment must be installed by a professional, and it must be installed in a place where it is out of the reach of people's grasp.

- Do not attempt to operate this unit if the power cord has been frayed or broken. Do not attempt to remove or break off the ground prong from the electrical cord. This prong is used to reduce the risk of electrical shock and fire in case of an internal short.
- Disconnect from main power before making any type of connection.
- Do not remove the cover under any conditions. There are no user serviceable parts inside.
- Never operate this unit when it's cover is removed.
- Never plug this unit in to a dimmer pack
- Always be sure to mount this unit in an area that will allow proper ventilation. Allow about 6" (15cm) between this device and a wall.
- Do not attempt to operate this unit, if it becomes damaged.
- During long periods of non-use, disconnect the unit's main power.
- Always mount this unit in safe and stable matter.
- Power-supply cords should be routed so that they are not likely to be walked on or pinched by items placed upon or against them, paying particular attention to the point they exit from the unit.
- Cleaning -The fixture should be cleaned only as recommended by the manufacturer. See page 23 for cleaning details.
- Heat -The appliance should be situated away from heat sources such as radiators, heat registers, stoves, or other appliances (including amplifiers) that produce heat.
- The fixture should be serviced by qualified service personnel when:
  - A. The power-supply cord or the plug has been damaged.
  - B. Objects have fallen, or liquid has been spilled into the fixture.
  - C. The fixture does not appear to operate normally or exhibits a marked change in performance.
  - D. The fixture has fallen and/or subjected to extreme handling.

**POTENTIAL INTERNAL FIXTURE DAMAGE FROM EXTERNAL SOURCES OF LIGHT BEAMS**

External sources of light beams from direct sunlight, lighting moving head fixtures, and lasers, which are focused directly towards the exterior housing and/or penetrate the front lens opening of ADJ lighting fixtures, can cause severe internal damage including burning to optics, dichroic color filters, glass and metal gobos, prisms, animation wheels, frost filters, iris, shutters, motors, belts, wiring, discharge lamps, and LEDs.

This issue is not specific only to ADJ lighting fixtures, it is a common issue with lighting fixtures from all manufacturers. Although there is no true way to fully prevent this issue from happening, the guidelines below can prevent any potential damage from occurring if followed. Contact ADJ Service for more details.

**DO NOT EXPOSE THE FIXTURE AND/OR FRONT LENS OPENING TO LIGHT BEAMS FROM DIRECT SUNLIGHT, OTHER LIGHTING MOVING HEAD FIXTURES, AND LASERS WHILE UNPACKING, INSTALLATION, USE, AND EXTENDED IDLE TIMES OUTDOORS.**

**DO NOT FOCUS A LIGHT BEAM FROM ONE LIGHTING FIXTURE DIRECTLY TOWARDS ANOTHER.**

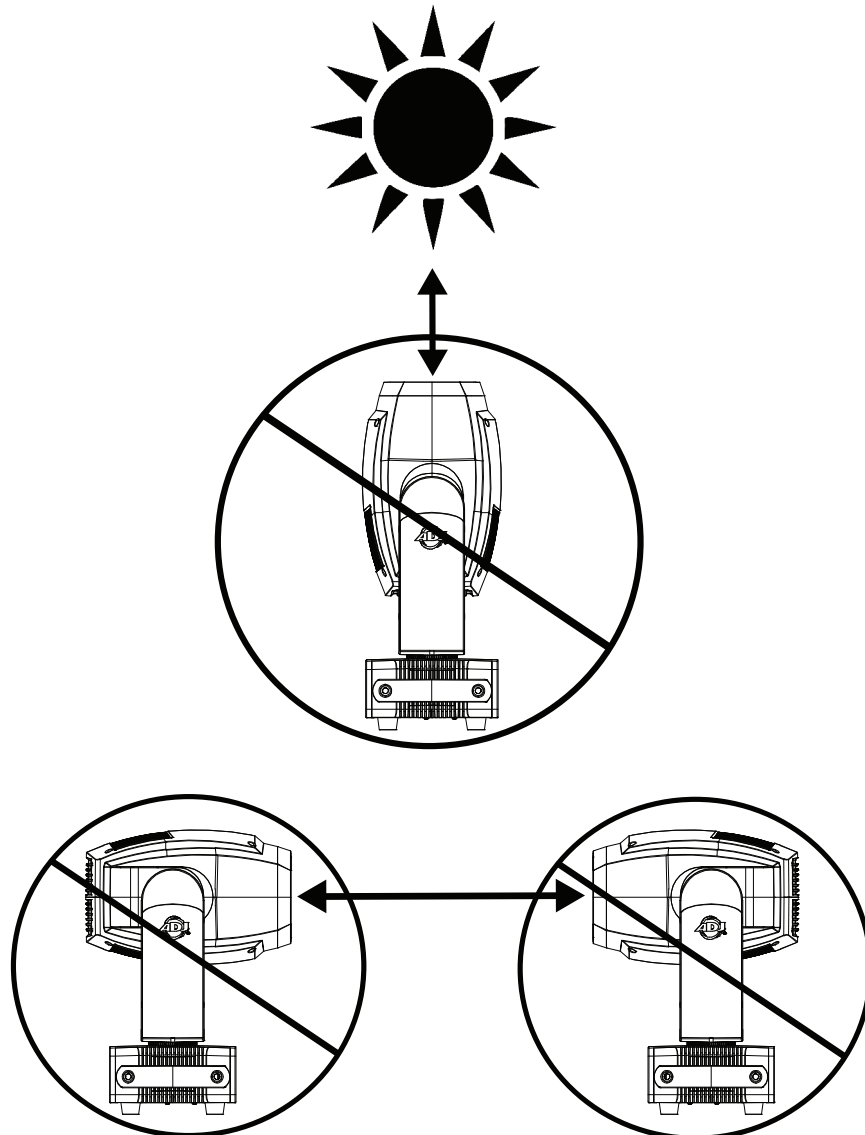

When installing the unit, the trussing or area of installation must be able to hold 10 times the weight without any deformation. When installing the unit must be secured with a secondary safety attachment, e.g. and appropriate safety cable. Never stand directly below the unit when mounting, removing, or servicing the unit.

Overhead mounting requires extensive experience, including calculating working load limits, installation material being used, and periodic safety inspection of all installation material and unit. If you lack these qualifications, do not attempt the installation yourself.

These installaiton should be checked by a skilled person once a year.

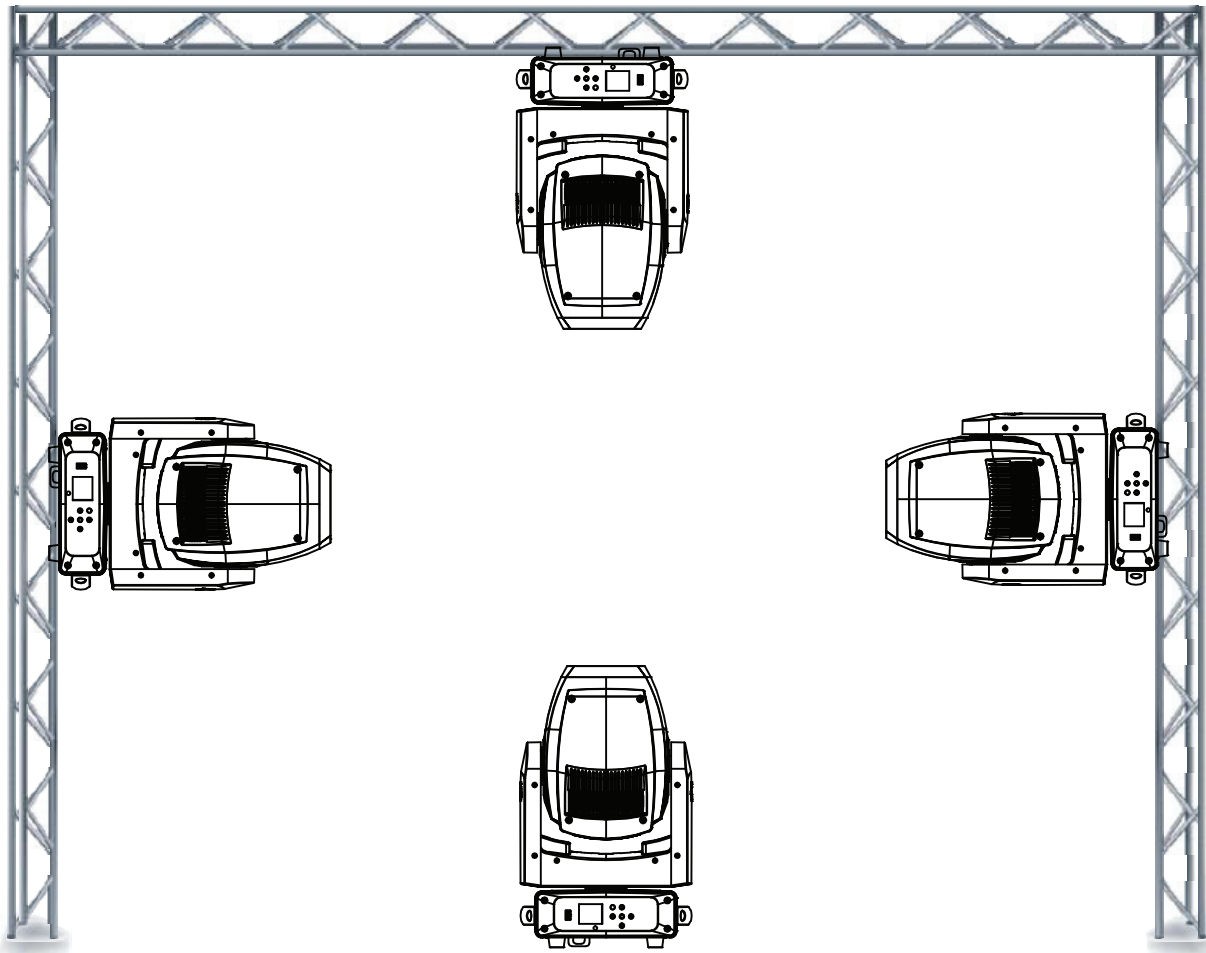

The Focus Spot 4Z is fully operational in three different mounting positions, hanging upside-down from a ceiling or trussing, sideways on trussing, or set on a flat level surface. Be sure this fixture is kept at least 12m (40ft) away from any flammable materials (decoration etc.). Always use and install the supplied safety cable as a safety measure to prevent accidental damage and/or injury in the event the clamp fails (see next page). Never use the carrying handles for secondary attachment.



**NOTICE:** The suitable environmental temperature for this lighting fixture is between  $-25^{\circ}\text{C}$  to  $45^{\circ}\text{C}$ . Do not place this lighting fixture in an environment where the temperatures are under or above the temperatures stated above. This will allow the fixture to run at its best and help prolong the fixture life.

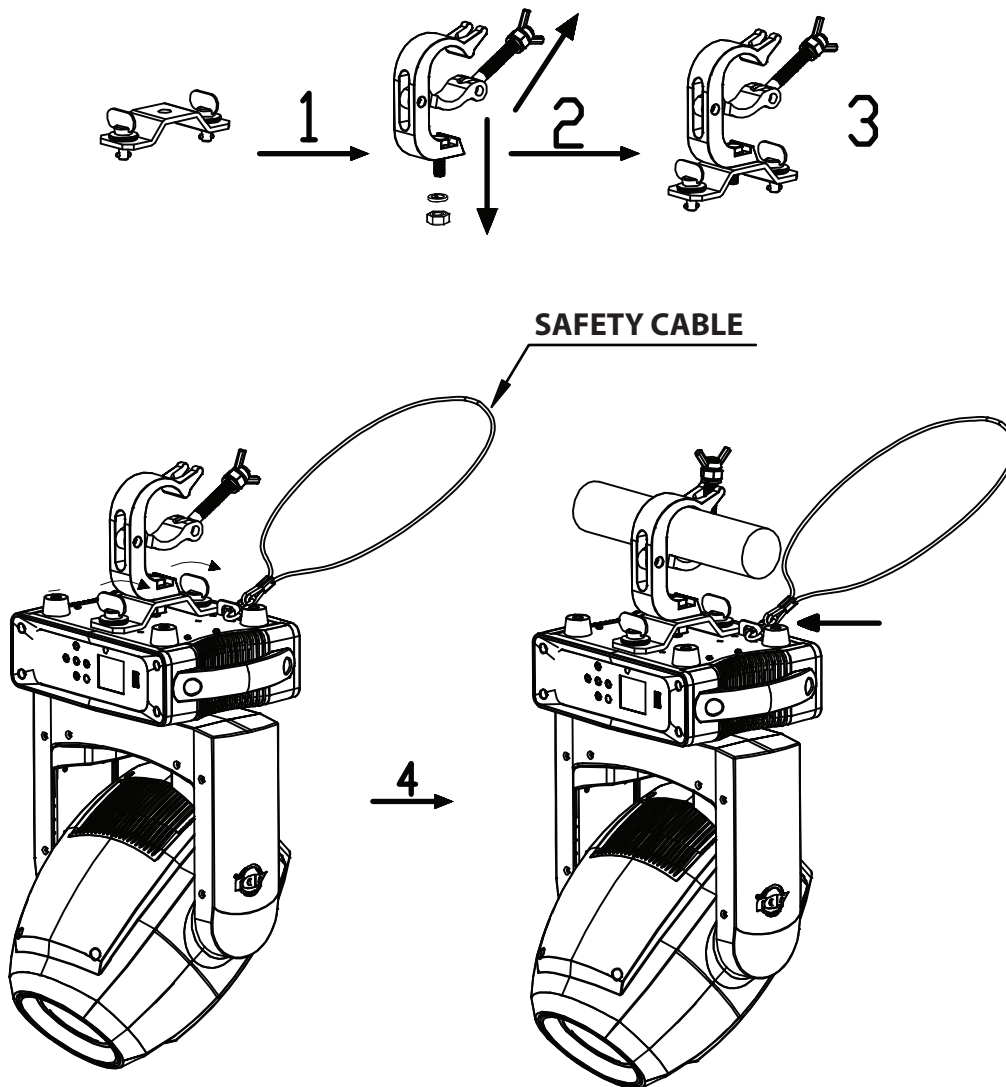

Screw one clamp each via a M12 screw and nut into the Omega bracket. Insert the quick-lock fasteners of the Omega holder's into the respective holes on the bottom of the Focus Spot 4Z. Tighten the quick-lock fasteners fully clockwise. Pull the safety cable through the openings located on the base plate and over the trussing system or a safe fixation spot. Insert the end in the carabine and tighten the safety screw.

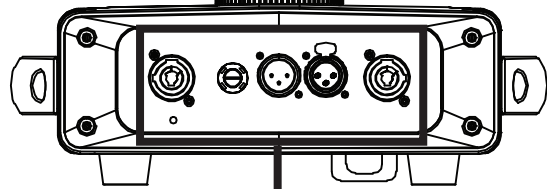
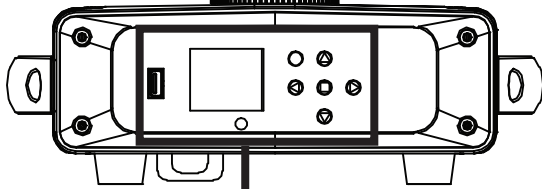
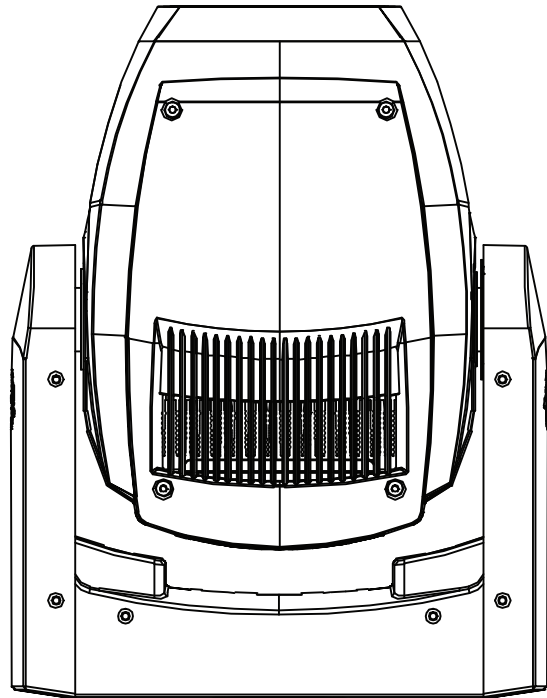
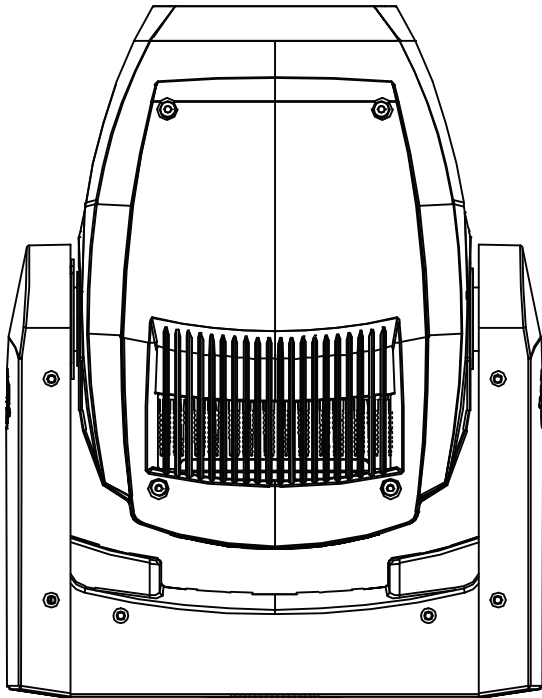

Service Port  
LED Display  
Mode Button  
Up Button  
Down Button  
Left Button  
Right Button  
Enter Button

powerCON In  
Fuse Holder  
3-Pin XLR Out  
3-Pin XLR In  
powerCON Out

**DMX-512:** DMX is short for Digital Multiplex. This is a universal protocol used as a form of communication between intelligent fixtures and controllers. A DMX controller sends DMX data instructions from the controller to the fixture. DMX data is sent as serial data that travels from fixture to fixture via the DATA “IN” and DATA “OUT” XLR terminals located on all DMX fixtures (most controllers only have a DATA “OUT” terminal).

**DMX Linking:** DMX is a language allowing all makes and models of different manufactures to be linked together and operate from a single controller, as long as all fixtures and the controller are DMX compliant. To ensure proper DMX data transmission, when using several DMX fixtures try to use the shortest cable path possible. The order in which fixtures are connected in a DMX line does not influence the DMX addressing. For example; a fixture assigned a DMX address of 1 may be placed anywhere in a DMX line, at the beginning, at the end, or anywhere in the middle. When a fixture is assigned a DMX address of 1, the DMX controller knows to send DATA assigned to address 1 to that unit, no matter where it is located in the DMX chain.

**Data Cable (DMX Cable) Requirements (For DMX Operation):** The Focus Spot 4Z can be controlled via DMX-512 protocol. The Focus Spot 4Z has 3 DMX channel modes. The DMX address is set on the front panel of the Focus Spot 4Z. Your unit and your DMX controller require a standard 3-pin XLR connector for data input and data output (Figure 1). We recommend Accu-Cable DMX cables. If you are making your own cables, be sure to use standard 110-120 Ohm shielded cable (This cable may be purchased at almost all pro lighting stores). Your cables should be made with a male and female XLR connector on either end of the cable. Also remember that DMX cable must be daisy chained and cannot be split.



Figure 1

**Notice:** Be sure to follow figures two and three when making your own cables. Do not use the ground lug on the XLR connector. Do not connect the cable’s shield conductor to the ground lug or allow the shield conductor to come in contact with the XLR’s outer casing. Grounding the shield could cause a short circuit and erratic behavior.

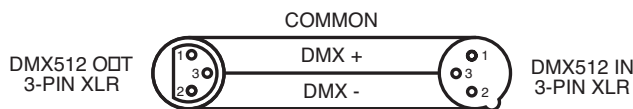

Figure 2

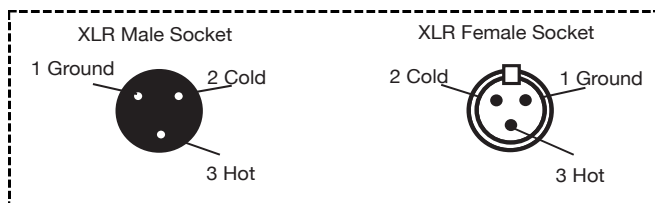
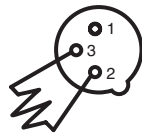

Figure 3

XLR Pin Configuration
Pin 1 = Ground
Pin 2 = Data Compliment (negative)
Pin 3 = Data True (positive)

**Special Note: Line Termination.** When longer runs of cable are used, you may need to use a terminator on the last unit to avoid erratic behavior. A terminator is a 110-120 ohm 1/4 watt resistor which is connected between pins 2 and 3 of a male XLR connector (DATA + and DATA -). This unit is inserted in the female XLR connector of the last unit in your daisy chain to terminate the line. Using a cable terminator (ADJ part number Z-DMX/T) will decrease the possibilities of erratic behavior.



Termination reduces signal errors and avoids signal transmission problems and interference. It is always advisable to connect a DMX terminal, (Resistance 120 Ohm 1/4 W) between PIN 2 (DMX-) and PIN 3 (DMX +) of the last fixture.

Figure 4

**5-Pin XLR DMX Connectors.** Some manufactures use 5-pin DMX-512 data cables for DATA transmission in place of 3-pin. 5-pin DMX fixtures may be implemented in a 3-pin DMX line. When inserting standard 5-pin data cables in to a 3-pin line a cable adaptor must be used, these adaptors are readily available at most electric stores. The chart below details a proper cable conversion.

3-Pin XLR to 5-Pin XLR Conversion		
Conductor	3-Pin XLR Female (Out)	5-Pin XLR Male (In)
Ground/Shield	Pin 1	Pin 1
Data Compliment (- signal)	Pin 2	Pin 2
Data True (+ signal)	Pin 3	Pin 3
Not Used		Do Not Use
Not Used		Do Not Use

All fixtures should be given a DMX starting address when using a DMX controller, so the correct fixture responds to the correct control signal. This digital starting address is the channel number from which the fixture starts to “listen” to the digital control signal sent out from the DMX controller. The assignment of this starting DMX address is achieved by setting the correct DMX address on the digital control display on the fixture.

You can set the same starting address for all fixtures or a group of fixtures, or set different addresses for each individual fixture. Setting all fixtures to the same DMX address will cause all fixtures to react in the same way, in other words, changing the settings of one channel will affect all the fixtures simultaneously.

If you set each fixture to a different DMX address, each unit will start to “listen” to the channel number you have set, based on the quantity of DMX channels of each fixture. That means changing the settings of one channel will only affect the selected fixture.

In the case of the Focus Spot 4Z, when in 16 channel mode you should set the starting DMX address of the first unit to 1, the second unit to 17 ( $16 + 1$ ), the third unit to 33 ( $17 + 16$ ), and so on. (See the chart below for more details.)

Channel Mode	Unit 1 Address	Unit 2 Address	Unit 3 Address	Unit 4 Address
16 Channels	1	17	33	49
18 Channels	1	19	37	55
22 Channels	1	23	45	67

Channel Modes & Values				Functions
Basic	Standard	Extended	Values	
1	1	1	000-255	<u>PAN Movement 8-bit:</u> Pan Movement By 630/540
	2	2	000-255	<u>Pan Fine 16-bit:</u> Fine control of Pan movement
2	3	3	000-255	<u>TILT Movement 8-bit:</u> Tilt Movement
	4	4	000-255	<u>Tilt Fine 16-bit:</u> Fine control of Tilt movement
3	5	5	000-007 008-014 015-021 022-028 029-035 036-042 043-049 050-056 057-063 064-127 128-189 190-193 194-255	<u>Color Wheel:</u> White Red Orange Yellow Green Blue Pink Cyan Magenta Color Mixing Color Wheel Clockwise Rotation Fast-Slow Nothing Color Wheel Counter-Clockwise Rotation Slow-Fast
4	6	6	000-004 005-019 020-034 035-049 050-064 065-079 080-094 095-109 110-124 125-139 140-154 155-169 170-189 190-221 222-223 224-255	<u>Gobo Wheel</u> Open Gobo 1 Gobo 2 Gobo 3 Gobo 4 Gobo 5 Gobo 6 Gobo 1 Shake Slow-Fast Gobo 2 Shake Slow-Fast Gobo 3 Shake Slow-Fast Gobo 4 Shake Slow-Fast Gobo 5 Shake Slow-Fast Gobo 6 Shake Slow-Fast Gobo Wheel Clockwise Rotation Fast-Slow Nothing Gobo Wheel Counter-Clockwise Rotation Slow-Fast
5	7	7	000-127 128-191 192-255	<u>Gobo rotation:</u> Gobo Rotation Indexing Gobo Rotation Clockwise Fast-Slow Gobo Rotation Counter-Clockwise Slow-Fast

Channel Modes & Values				Functions
Basic	Standard	Extended	Values	
6	8	8	000-031 032-063 064-095 096-127 128-159 160-191 192-223 224-255	<u>Shutter &amp; Strobing:</u> Shutter Closed (Not Function) Shutter Open Strobing Slow-Fast Shutter Open Pulse Strobing Slow-Fast Shutter Open Random Strobing Slow-Fast Shutter Open
7	9	9	000-255	<u>Master Dimmer:</u> Intensity 0 to 100%
		10	000-255	<u>Dimmer Fine 16-bit:</u>
8	10	11	000-031 032-255	<u>Prism 1:</u> Open 6 Facet Circular Prism
9	11	12	000-127 128-189 190-193 194-255	<u>Prism 1 Indexing &amp; Rotation:</u> Prism 1 Indexing Clockwise Rotation Fast-Slow No Rotation Counter-Clockwise Rotation Slow-Fast
		13	000-255	<u>Prism 1 Indexing Fine 16-bit:</u>
10	12	14	000-031 032-255	<u>Prism 2:</u> Open 5 Facet Linear Prism
11	13	15	000-127 128-189 190-193 194-255	<u>Prism 2 Indexing &amp; Rotation:</u> Prism 1 Indexing Clockwise Rotation Fast-Slow No Rotation Counter-Clockwise Rotation Slow-Fast
		16	000-255	<u>Prism 2 Indexing Fine 16-bit:</u>
12	14	17	000-255	<u>Focus:</u> Continuous adjustment from far to near
13	15	18	000-255	<u>Zoom:</u> Zoom from min. to max.beam angle
		19	000-255	<u>Zoom Fine 16-bit:</u>

Channel Modes & Values				Functions
Basic	Standard	Extended	Values	
14	16	20	000-020 021-040 041-060 061-080 081-100 101-120 121-255	<u>Dim Curves:</u> Standard Stage TV Architectural Theatre Stage 2 Default tu Unit Setting
15	17	21	000-255	<u>Pan/Tilt Speed:</u> Max to min speed
16	18	22	000-009 010-019 020-029 030-039 040-059 060-069 070-079 080-089 090-099 100-119 120-139 140-159 160-179 180-199 200-219 220-239 240-255	<u>Function, reset, internal programs</u> No Function Blackout with Pan/Tilt Movement Blackout with Color Wheel Movement Blackout with Gobo Wheel Movement Color and Gobo Motor Reset Prism Motor Reset Pan & Tilt Motor Reset Focus Motor Reset All Motors Reset Internal Program 1 (Scene 1~8 of EEPROM) Internal Program 2 (Scene 9~16 of EEPROM) Internal Program 3 (Scene 17~24 of EEPROM) Internal Program 4 (Scene 25~32 of EEPROM) Internal Program 5 (Scene 33~40 of EEPROM) Internal Program 6 (Scene 41~48 of EEPROM) Internal Program 7 (Scene 49~56 of EEPROM) No Function

**Inner Diameter: 19mm**  
**Outer Diameter: 23mm**  
**Thickness: 0.5mm**

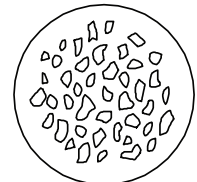
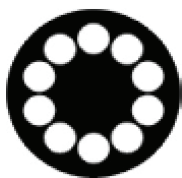

Gobo 1

Gobo 2

Gobo 3

Gobo 4

Gobo 5

Gobo 6



MENU	SUB MENU	OPTIONS/VALUES (DEFAULT SHADED)	DESCRIPTION	
<b>DISPLAY MENU</b>	Software Update Please Wait FOCUS SPOT 4Z Motor Reset Please Wait...			
	<b>RECEIVE</b>	Set Address	A001~AXXX	
<b>USER MODE</b>	User Mode	Standard (18 Channel Mode) Basic (16 Channel Mode) Extend (22 Channel Mode) User A User B User C		
		Edit A Edit B Edit C	Max Channel PAN :	
<b>FUNCTION</b>	Status	No DMX Mode	Hold/Auto/Black	
		P.Reverse	ON/OFF	
	T.Reverse	ON/OFF		
	Pan Degree	630/540		
	Feedback	ON/OFF		
	Move.Speed	Speed 1~4		
	Hibernation	OFF, 01M~99M	15M	
	Dim Mode	Standard Stage TV Architectur Theatre Stage2		
		Temp. C/F	Celsius Fahrenheit	
	Gamma	2.0/2.2/2.4/2.6/2.8		
Frequency	900Hz/1000Hz/1100Hz/ 1200Hz/1300Hz/1400Hz/ 1500Hz/2500Hz/4000Hz/ 5000Hz/10KHz/15KHz/ 20KHz/25KHz			
Fan Set	Head Fan	Auto		
		High Low		
LCD.Set	Backlight	02~60m	<05m>	
	FlipDisplay	ON/OFF		
Disp.Set	Key Lock	ON/OFF/ON1		
	Disp Flash	ON/OFF		
USB Update	Chan.Value	PAN.....		
	Slave Set	Slave1,Slave2,Slave3		
DFSE	Auto.Prog	Master / Alone		
	USB Update	OFF/ON		
DFSE	ON/OFF			

MENU	SUB MENU	OPTIONS/VALUES (DEFAULT SHADED)	DESCRIPTION
INFORMATION	Time.Info	CurrentTime Total Time Last Time  Timer PIN  Clear Last Clear Total	Current Running Time (Hours) Total Running Time (Hours) Total Running Time (Hours)  Last Time Clear: (Password=050) Total Time Clear: (Password=060) ON/OFF ON/OFF
	Temp. Info	T:XXX	
	Fan Speed	Fan1: XXXX RPM Fan2: XXXX RPM	
	Error.Info	NONE/Pan,Tilt ...	
	Model. Info	FOCUS SPOT 4Z	
	Software.V	1U: VX.X.X 2U: VX.X.X 3U: VX.X.X	
TEST	Reset.Motor	All Pan&Tilt Color&Gobo	
	TestChannel	Pan/Pan Fine/Tilt/Tilt Fine/ColorWheel/Gobo/RotGobo/ Strobe/Dimmer/Dim Fine/Prism1/Prism1Rot/Prism1 Fine/ Prism2/Prism2Rot/Prism2 Fine/Focus/Zoom/ZoomFine/ DimMode/P/T Speed/Reset/Prog	
	Panel.Ctrl	Pan/Pan Fine/Tilt/Tilt Fine/ColorWheel/Gobo/RotGobo/ Strobe/Dimmer/Prism1/Prism1Rot/Prism2/Prism2Rot/ Focus/Zoom/DimMode/P/T Speed/ Reset/Prog	
	Calibrate	Password Pan/Tilt/ColorWheel/Gobo/RotGobo/Prism1/ Prism1Rot/Prism2/Prism2Rot/Focus/Zoom	(Password=050)
PROGRAM	Select.Prog	Prog.Part 1 = Program 1~9 Prog.Part 2 = Program 1~9 Prog.Part 3 = Program 1~9	Program 1 Program 2 Program 3
	Edit.Prog	Program 1 : Program 9	Program Test Step 01=SCxxx Step 64=SCxxx
	Edit.Scene	Edit Scene 001 ~ Edit Scene 250	Pan,Tilt, ..... Fade Time Secne Time

The main menu is accessed by pressing the MODE button. Browse through the menu by using the UP, DOWN, RIGHT, & LEFT buttons. Press the ENTER button to access the desired menu. You can scroll through the submenus using the UP and DOWN buttons. To confirm every selection press the ENTER button. You can exit every menu and submenu by pressing the MODE button. The unit will automatically exit the menus if no buttons are pressed after 10 seconds. These next pages will explain each function in the system menu located on the previous pages.

**SET ADDRESS** - With this function, you can adjust and set your desired DMX address.

1. Access the main menu, and press the UP or DOWN buttons until “**Receive**” is highlighted, then press ENTER.
2. “**Set Address**” will now be displayed, press ENTER. The current DMX address will now be displayed.
3. Use the UP or DOWN buttons to adjust the DMX address.
4. Press the ENTER button to confirm your address or press the MODE button to exit.

**USER MODE** - This mode will let you select your desired DMX Channel mode.

1. Press the MODE button to access the main menu. Press the UP or DOWN buttons until “**User Mode**” is highlighted, then press ENTER. Highlight “**User Mode**” once again and press ENTER.
2. Use the UP or DOWN buttons to scroll through the 3 DMX Channel Modes. See the DMX channel modes listed below. Press the ENTER button to confirm your selection or press the MODE button to exit.

- **Basic Mode** - This is 16 Channel Mode.
- **Standard Mode** - This is 18 Channel Mode.
- **Extended Mode** - This is 22 Channel Mode.

**User Mode A B C** - These are customizable DMX modes. Select either of these modes and set the amount of DMX Channels and what each channel does.

3. Press the ENTER button to confirm your settings or press the MODE button to exit.

**NO DMX MODE** - With this function if the DMX signal is suddenly lost, the unit will automatically go into 1 of 3 modes.

1. Press the MODE button to access the main menu. Press the UP or DOWN buttons until “**Function**” is highlighted, then press ENTER.
2. Press the UP or DOWN buttons until “**Status**” is highlighted, then press ENTER.
3. Press the UP or DOWN buttons, until “**No DMX Mode**” is highlighted, then press ENTER.
4. Either “**Hold**” (Last DMX setting), “**Black**” (Blackout), or “**Auto**” (Auto Program) will be displayed, use the UP or DOWN buttons to scroll through the options.
5. Press the ENTER button to confirm your selection or press the MODE button to exit.

**PAN INVERSE** - With this function you can reverse the Pan movement.

1. Press the MODE button to access the main menu. Press the UP or DOWN buttons until **“Function”** is highlighted, then press ENTER.
2. Press the UP or DOWN buttons until **“Status”** is highlighted then press ENTER.
3. Press UP or DOWN buttons until **“P. Reverse”** is highlighted then press ENTER.
4. Either **“Off”** or **“On”** will be displayed. Press the UP or DOWN buttons to find your desired setting.
5. Press the ENTER button to confirm your setting or press the MODE button to exit.

**TILT INVERSE** - With this function you can reverse the left head Tilt movement. This function is used with DMX mode.

1. Press the MODE button to access the main menu. Press the UP or DOWN buttons so that **“Function”** is highlighted, then press ENTER.
2. Press the UP or DOWN buttons until **“Status”** is highlighted then press ENTER.
3. Press the UP or DOWN buttons until **“T. Reverse”** is highlighted then press ENTER.
4. Either **“Off”** or **“On”** will be displayed. Press the UP or DOWN buttons to find your desired setting.
5. Press the ENTER button to confirm your setting or press the MODE button to exit.

**PAN DEGREE** - With this function you can change the pan degree from 630 to 540. This function is used with DMX mode.

1. Press the MODE button to access the main menu. Press the UP or DOWN buttons so that **“Function”** is highlighted, then press ENTER.
2. Press the UP or DOWN buttons until **“Status”** is highlighted press ENTER.
3. Press THE UP or DOWN buttons until **“Pan Degree”** is highlighted and press ENTER.
4. Either **“540”** or **“630”** will be displayed. Use the UP or DOWN buttons to find your desired setting.
5. Press the ENTER button to confirm your selection or press the MODE button to exit.

**FEEDBACK** - With this function, you have the pan and tilt position feedback while out of step or not feedback while out of step.

1. Press the MODE button to access the main menu. Press the UP or DOWN buttons so that **“Function”** is highlighted, then press ENTER.
2. Press the LEFT or RIGHT buttons until **“Status”** is highlighted press ENTER.
3. Press LEFT or RIGHT buttons, until **“Feedback”** is highlighted and press ENTER.
4. Either **“Off”** or **“On”** will be displayed. Use the UP or DOWN buttons to find your desired setting.
5. Press the ENTER button to confirm your selection or press the MODE button to exit.

**MOVEMENT SPEED** - With this function you can set the pan and tilt movement speed.

1. Press the MODE button to access the main menu. Press the UP or DOWN buttons until **“Function”** is highlighted, then press ENTER.
2. Press the UP or DOWN buttons until **“Status”** is highlighted then press ENTER.
3. Press UP or DOWN buttons until **“Move. Speed”** is highlighted then press ENTER.
4. Either **“Speed1”**, **“Speed2”**, **“Speed3”** or **“Speed4”** will be displayed. Use the UP or DOWN buttons to find your desired setting.
5. Press the ENTER button to confirm your selection or press the MODE button to exit.

**HIBERNATION** - With this function the LEDs and step motors will power off if there is no DMX signal within 15 mins (factory default). Once it receives a DMX signal, the fixture will reset itself.

1. Press the MODE button to access the main menu. Press the UP or DOWN buttons until **“Function”** is highlighted, then press ENTER.
2. Press the UP or DOWN buttons until **“Status”** is highlighted then press ENTER.
3. Press UP or DOWN buttons, until **“Hibernation”** is highlighted then press ENTER.
4. The current stand by setting will be displayed, use the LEFT or RIGHT buttons to adjust the hibernation period between **“01M-99M”** or **“Off”**.
5. Press the ENTER button to confirm your selection or press the MODE button to exit.

**DIMMER MODE** - With this function you can change dimmer curve setting. See page 28 for the Dimmer Curve Chart.

1. Press the MODE button to access the main menu. Press the UP or DOWN buttons so that **“Function”** is highlighted, then press ENTER.
2. Press the UP or DOWN buttons until **“Dim Mode”** is highlighted then press ENTER.
3. The dimmer curve settings will now be displayed.
4. Use the UP or DOWN buttons to find your desired dimmer curve setting.
5. Press the ENTER button to confirm your selection or press the MODE button to exit.

**TEMPERATURE C/F** - With this function, you can change the temperature display to show either Celsius or Fahrenheit.

1. Press the MODE button to access the main menu. Press the UP or DOWN buttons so that **“Function”** is highlighted, then press ENTER.
2. Press UP or DOWN buttons until **“Temp. C/F”** is highlighted then press ENTER.
3. Either **“Celsius”** or **“Fahrenheit”** will be displayed, use the UP or DOWN buttons to find your desired setting.
4. Press the ENTER button to confirm your selection or press the MODE button to exit.

**GAMMA ADJUSTMENT** - With this function, you are able to adjust the gamma setting. This feature is predominately used when shooting video.

1. Access the main menu, and press the UP or DOWN buttons until “**Function**” is highlighted, then press ENTER.
2. Press the UP or DOWN buttons until “**Gamma**” is highlighted, and press ENTER. The current setting will now be displayed.
3. Use the UP or DOWN buttons to find your desired setting.
4. Press the ENTER button to confirm your selection or press the MODE button to exit.

**FREQUENCY ADJUSTMENT** - With this function, you are able to adjust the dimming frequency. This feature is predominately used when shooting video and achieving flicker free operation.

1. Access the main menu, and press the UP or DOWN buttons until “**Function**” is highlighted, then press ENTER.
2. Press the UP or DOWN buttons until “**Frequen**” is highlighted, then press ENTER. The current setting will now be displayed.
3. Use the UP or DOWN buttons to find your desired setting.
4. Press the ENTER button to confirm your selection or press the MODE button to exit.

**FAN SET** - With this function, you can control the moving head fan speed.

1. Access the main menu, and press the UP or DOWN buttons until “**Function**” is highlighted, then press ENTER.
2. Press the UP or DOWN buttons until “**Fan Set**” is highlighted, and press ENTER.
3. “**Head Fan**” will now be displayed, press ENTER.
4. Use the UP or DOWN buttons to make the adjustments to the fan.
5. Press the ENTER button to confirm your selection or press the MODE button to exit.

**BACKLIGHT** - With this function you can have the LCD display backlight after 2-60 minutes. Use this function to adjust the time.

1. Press the MODE button to access the main menu. Press the UP or DOWN buttons until “**Function**” is highlighted, then press ENTER.
2. Press the UP or DOWN buttons until “**LCD.Set**” is highlighted, press ENTER.
3. Press UP or DOWN buttons, until “**Backlight**” is highlighted, and press ENTER.
4. “**05m**” (5 minutes) will be displayed, this is the default setting. Use the LEFT or RIGHT buttons to adjust the shutoff time between 02m-60m or “**Off**”.
5. Press the ENTER button to confirm your selection or press the MODE button to exit.

**FLIP DISPLAY** - With this function you can rotate (flip) the display 180 degrees.

1. Press the MODE button to access the main menu. Press the UP or DOWN buttons so that **“Function”** is highlighted, then press ENTER.
2. Press the UP or DOWN buttons until **“LCD.Set”** is displayed, press ENTER.
3. Press UP or DOWN buttons, until **“Flip Display”** is displayed, and press ENTER.
4. Either **“Off”** or **“On”** will be displayed. Use the LEFT or RIGHT buttons find your setting.
5. Press the ENTER button to confirm your selection or press the MODE button to exit.

**KEY LOCK** - With this function activated the buttons will lock automatically after 15 seconds.

1. Press the MODE button to access the main menu. Press the UP or DOWN buttons so that **“Function”** is highlighted, then press ENTER.
2. Press the UP or DOWN buttons until **“LCD.Set”** is highlighted, then press ENTER.
3. Press UP or DOWN buttons, until **“Key Lock”** is highlighted, then press ENTER.
4. Use the LEFT and RIGHT buttons to scroll through the key lock options, and press ENTER to make your selection.
  - **“OFF”** - The keypad is unlocked, simply press the MODE button to activate the keypad.
  - **“ON”** - This is a simple keypad lock. Press the MODE button for at least 5 seconds to unlock the keypad.
  - **“ON1”**. This setting is used to prevent the accidental unlocking of the keypad. To unlock the keypad you will have to enter a passcode. To unlock the keypad press UP, DOWN, UP, DOWN, & ENTER in that order.
5. Press the ENTER button to confirm your selection or press the MODE button to exit.

**DISPLAY FLASH** - With this function active, the display will flash when the DMX signal is lost.

1. Press the MODE button to access the main menu. Press the UP or DOWN buttons so that **“Function”** is highlighted, then press ENTER.
2. Press the UP or DOWN buttons until **“LCD.Set”** is highlighted, then press ENTER.
3. Press UP or DOWN buttons, until **“DispFlash”** is highlighted, then press ENTER.
4. Either **“Off”** or **“On”** will be displayed. Use the LEFT or RIGHT buttons find your setting.
5. Press the ENTER button to confirm your selection or press the MODE button to exit.

**CHANNEL VALUE** - This function will allow you to see the DMX value of each DMX channel that is currently being used at the time.

1. Press the MODE button to access the main menu. Press the UP or DOWN buttons so that **“Function”** is highlighted, then press ENTER.
2. Press the UP or DOWN buttons until **“Disp.Set”** is highlighted, then press ENTER.
3. Press the UP or DOWN buttons until **“Chan. Value”** is highlighted, then press ENTER.
4. A DMX Channel will now be displayed. **Example:** Pan, Rotation, LED's etc... Press ENTER when you find the DMX channel that you would like to check. When you press ENTER the DMX value of that channel will displayed.
5. Press the MODE button to exit.

**SLAVE SET** - This function lets you designate the unit as the slave in a Master-Slave configuration.

1. Press the MODE button to access the main menu. Press the UP or DOWN buttons so that **“Function”** is highlighted, then press ENTER.
2. Press the UP or DOWN buttons until **“Disp.Set”** is highlighted, then press ENTER.
3. Press the UP or DOWN buttons until **“Slave Set”** is highlighted, then press ENTER.
4. Either **“Slave 1”**, **“Slave 2”**, or **“Slave 3”** will be displayed. Use the UP or DOWN buttons to find your desired setting.
5. Press the ENTER button to confirm your selection or press the MODE button to exit.

**AUTO PROGRAM** - This function allows the internal programs to run in either stand-alone or master/slave set up. In **“Master”** mode the fixture will send DMX data to other fixtures connected via DMX cable. In **“Alone”** mode the fixture will operate as a single fixture. The program for this mode is selected in the **“Program”** section of the control menu. You can set the number of steps under **“Edit.Prog”**. You can edit the individual scenes under **“Edit Scenes”**.

1. Press the MODE button to access the main menu. Press the UP or DOWN buttons so that **“Function”** is highlighted, then press ENTER.
2. Press the UP or DOWN buttons until **“Disp.Set”** is displayed, press ENTER.
3. Press the UP or DOWN buttons until **“Auto. Prog”** is displayed, and press ENTER.
4. Either **“Master”** or **“Alone”** will be displayed. Use the UP or DOWN buttons to find your desired setting.
5. Press the ENTER button to confirm your selection or press the MODE button to exit.

**DEFAULT SETTINGS** - With this function you can restore the factory settings.

1. Press the MODE button to access the main menu. Press the UP or DOWN buttons so that **“Function”** is highlighted, then press ENTER.
2. Press the UP or DOWN buttons so that **“DFSE”** is highlighted, then press ENTER.
3. Either **“Off”** or **“On”** will now be displayed. Use the LEFT or RIGHT buttons to find your selection. Selecting **“On”** will restore the factory settings.
4. Press the ENTER button to confirm your selection or press the MODE button to exit.

**USB UPGRADE FILE** - This submenu is used for any future software updates. Check [www.adj.com](http://www.adj.com) and this units webpage for any software updates. Download the software update to a flash stick and plug the flash stick into the Service Port slot located on the front of the unit.

1. Contact ADJ customer service for help when updating software.



**TIME INFO** - In this submenu are able to check the current running time, total running time, and last clear time. This submenu will also let you clear/reset the “Total Time” and “Last Time” hours.

1. Press the MODE button to access the main menu. Press the UP or DOWN buttons until “**Information**” is highlighted, then press ENTER.
2. Press the UP or DOWN buttons until “**Time.Info**” is highlighted, then press ENTER.
3. Press UP or DOWN buttons to scroll through the time information selections.
  - “**Current Time**” - This will display the current running time of the fixture in hours. Press the ENTER or MODE button to exit.
  - “**Total Time**” - This will display the total running time of the fixture in hours. Press the ENTER or MODE button to exit.
  - “**Last Time**” - This will display the last time the running time was cleared. Press the ENTER or MODE button to exit.
  - “**Time PIN**” - This function will allow you to clear the “Last Time” and “Total Time” displays.
  - “**Clear Last**” - This function will allow you to clear the “Last Time” counter. Access “**Time PIN**” and press ENTER. Using the UP and DOWN buttons set the “PIN” to “050” and press ENTER. Return to the “**Clear Last**” function and press ENTER. Press the LEFT or RIGHT buttons until your selection is displayed and press ENTER to confirm. “ON” will clear the time. “OFF” will return you to the Time Menu.
  - “**Clear Total**” - This function will allow you to clear the “Total Time” counter. Access “**Time PIN**” and press ENTER. Using the UP and DOWN buttons set the “PIN” to “060” and press ENTER. Return to the “**Clear Total**” function and press ENTER. Press the LEFT or RIGHT buttons until your selection is displayed and press ENTER to confirm. “ON” will clear the time. “OFF” will return you to the Time Menu.

**TEMPERATURE INFO** - This will allow you to check the moving head temperature.

1. Press the MODE button to access the main menu. Press the UP or DOWN buttons until “**Information**” is highlighted, then press ENTER.
2. Press the UP or DOWN buttons until “**Temp. Info**” is highlighted, then press ENTER.
- 3.. “**T:XXX**” will now be displayed. “**XXX**” represents the current temperature of the moving head.
4. Press the ENTER button or MODE button to exit.

**FAN SPEED** - With this function, you can control the base fan speed.

1. Press the MODE button to access the main menu. Press the UP or DOWN buttons until “**Information**” is highlighted, then press ENTER.
2. Press the UP or DOWN buttons until “**Fan Speed**” is highlighted, then press ENTER.
3. The current fan speeds of “**Fan1**” and “**Fan2**” will now be displayed.
4. Press the ENTER or MODE button to exit.

**ERROR INFO** - This submenu will display any function errors that may occur. If any error warnings appear and you are not certain on what form of action needs to be taken, please contact ADJ customer support for more information.

1. Press the MODE button to access the main menu. Press the UP or DOWN buttons so that **“Information”** is highlighted, then press ENTER.
2. Press the UP or DOWN buttons until **“Error. Info”** is highlighted, then press ENTER.
3. Any errors that have may occurred will now be displayed. Press the MODE button to exit.

**MODEL INFORMATION** - This will display the model name

1. Press the MODE button to access the main menu. Press the UP or DOWN buttons so that **“Information”** is highlighted, then press ENTER.
2. Press the UP or DOWN buttons until **“Model.Info”** is highlighted, then press ENTER.
3. The model name will now be displayed.
4. Press the ENTER or MODE button to exit.

**SOFTWARE VERSION** - This will display the current software version.

1. Press the MODE button to access the main menu. Press the UP or DOWN buttons until **“Information”** is highlighted, then press ENTER.
2. Press the UP or DOWN buttons until **“Software.V”** is highlighted, then press ENTER.
3. The current software versions will now be displayed.
4. Press the ENTER or MODE button to exit.

**RESET MOTOR** - This will allow you to reset the pan, tilt, color wheel, gobo wheel motors, or all motors.

1. Press the MODE button to access the main menu. Press the UP or DOWN buttons so that **“Test”** is highlighted, then press ENTER.
2. Press the UP or DOWN buttons until **“Reset.Motor”** is highlighted, then press ENTER.
3. Press the UP or DOWN buttons to find the motors you would like to reset.
4. Press the ENTER button to reset or press the MODE button to exit.

**TEST CHANNEL** - With this function you can test each of the channel functions.

1. Press the MODE button to access the main menu. Press the UP or DOWN buttons so that **“Test”** is highlighted, then press ENTER.
2. Press the UP or DOWN buttons until **“TestChannel”** is highlighted, then press ENTER.
3. Use the UP or DOWN buttons to scroll through the channel functions.
4. Press ENTER to select a channel to test or press MODE to exit.

**PANEL CONTROL** - With this function you can make fine adjustments.

1. Press the MODE button to access the main menu. Press the UP or DOWN buttons so that “**Test**” is highlighted, then press ENTER.
2. Press the UP or DOWN buttons until “**Panel. Ctrl**” is displayed, press ENTER.
3. Use the UP or DOWN buttons to scroll through the various functions.
4. Press ENTER when you find the function you would like to adjust or press MODE to exit.

**CALIBRATE** - With this function you can calibrate and adjust the effect wheels to their correct positions. The Calibration password 050. **NOTE: ONLY QUALIFIED TECHNICIANS SHOULD PERFORM THIS FUNCTION.**

1. Press the MODE button to access the main menu. Press the UP or DOWN buttons so that “**Test**” is highlighted, then press ENTER.
2. Press the UP or DOWN buttons until “**Calibrate**” is displayed, press ENTER.
3. “XXXX” will be displayed. The password is 050.
4. Press ENTER to confirm or press MODE to exit.

## PROGRAM

**EDIT PROGRAM:** - The fixture comes equipped with a built-in DMX recorder that allows custom programs to be installed and recalled directly from the fixture’s control board. Programs can be created and stored using the fixture’s control board or by using an external DMX controller.

**Select.Prog** – This function allows the user to select one of nine of the user defined built-in programs. This program is then accessed in “Function Mode” under “Program Run.”

**Edit.Prog** – This function allows the user to edit the built-in programs.

**Edit.Scene** – This function allows the user to edit or define the actual scenes that are stored in the user defined built-in programs that are accessed in the previous step.

**Master-Slave Configuration:**

This function will allow you to link units together to run in a Master-Slave set-up. In a Master-Slave set up one unit will act as the controlling unit and the others will react to the controlling units built-in programs. Any unit can act as a Master or as a Slave however, only one unit can be programmed to act as the “Master.”

**Master-Slave Connections and Settings:**

1. Daisy chain your units via the XLR connector on the rear of the unit. Use standard XLR data cables to link your units together. Remember that the Male XLR connector is the input and the Female XLR connector is the output. The first unit in the chain (master) will use the female XLR connector only. The last unit in the chain will use the male XLR connector only.
2. Connect the first “Slave” unit to the “Master.”
3. **Master Unit:**
  - Press the MODE button to access the main menu. Press the UP or DOWN buttons so that “**Function**” is highlighted, then press ENTER.
  - Press the UP or DOWN buttons until “**Disp.Set**” is displayed, press ENTER.
  - Press the UP or DOWN buttons until “**Auto. Prog**” is displayed, and press ENTER.
  - Either “**Master**” or “**Alone**” will be displayed. Use the UP or DOWN buttons to highlight “Master”.
  - Press the ENTER button to confirm your selection.
4. **Slave Unit(s):**
  - Press the MODE button to access the main menu. Press the UP or DOWN buttons so that “**Function**” is highlighted, then press ENTER.
  - Press the UP or DOWN buttons until “**Disp.Set**” is highlighted, then press ENTER.
  - Press the UP or DOWN buttons until “**Slave Set**” is highlighted, then press ENTER.
  - Either “**Slave 1**”, “**Slave 2**”, or “**Slave 3**” will be displayed. Use the UP or DOWN buttons to find your desired slave setting.
5. Press the ENTER button to confirm your selection.

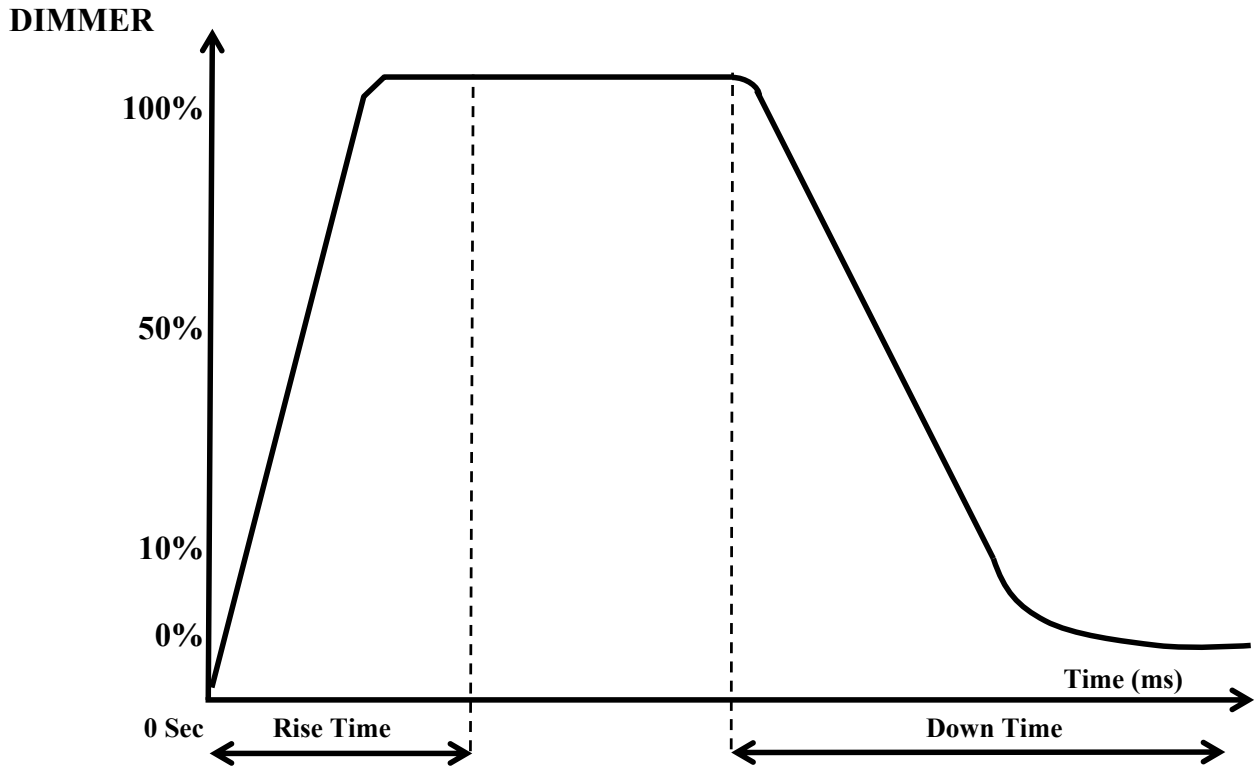

Dimming Curve Ramp Effect	0 sec Fade Time		1 sec Fade Time	
	Rise Time (ms)	Down Time (ms)	Rise Time (ms)	Down Time (ms)
Standard (default)	0	0	0	0
Stage	780	1100	1540	1660
TV	1180	1520	1860	1940
Architectural	1380	1730	2040	2120
Theatre	1580	1940	2230	2280
Stage 2	0	1100	0	1660

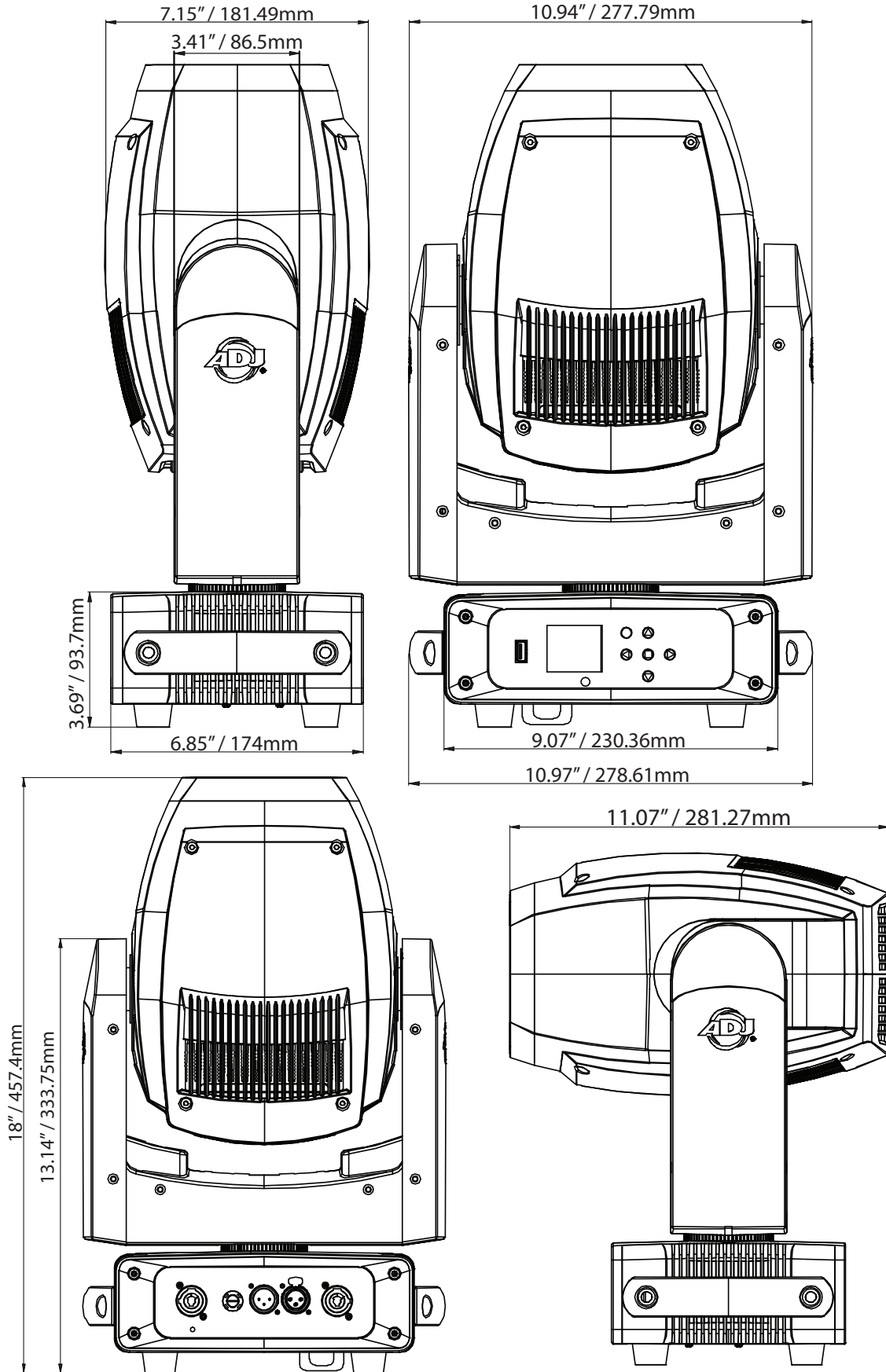

The gobo's featured in this unit are interchangeable. Remember when changing these gobo's that they are thin and easy to bend. Please do this process gently so you do not bend or damage gobo.

**Caution!** *Never open the unit when in use. Always disconnect the main power before attempting to change the gobos.*

**Locating the Gobo wheel:** After disconnecting the main power, position the head with the lens facing forward. Look through lens of the unit. When looking through the front lens, position the head so that the gears are on the right side. When the gears are on the right side, the shell that needs to be unscrewed is now facing up.

1. To change a gobo, unscrew the 4 screws that secure the shell to the unit. Gently lift and remove the shell.
2. When you remove the shell you will be able to access the gobo wheel. Turn the wheel with your hand until you come across the gobo you would like to change.
3. To change the gobo you have to remove the individual gobo frames. Gently push the gobo and gobo frame (Not the wheel) away from the gobo wheel. You do not have to push very hard. While you are pushing the gobo frame away from the wheel, gently pull the the gobo frame up and out.
4. Once the gobo frame has been removed, you will notice that a retainer ring secures the gobo in place. After the retainer ring is removed, your are able to remove the gobo.
5. Change the gobo and replace the retainer ring.
6. Insert the gobo frame back into the unit, positioning it in same way as the other gobo frames.
7. Reassemble the unit.

**Inner Diameter: 19mm**

**Outer Diameter: 23mm**

**Thickness: 0.5mm**

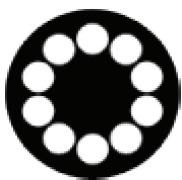

Gobo 1

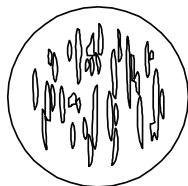

Gobo 2



Gobo 3

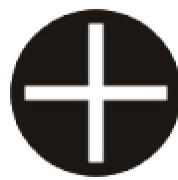

Gobo 4



Gobo 5

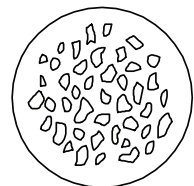

Gobo 6

## Focus Spot 4Z

## Fuse Replacement

Unplug the unit from any power source it may be connected to. Once the power has been disconnected, use a flat head screw driver to unscrew the fuse holder located next to the powerCON input. Remove the bad fuse and replace with a new one, and screw the fuse holder back in.

## Focus Spot 4Z

## Multiple Unit Power Linking

With this feature you can connect the fixtures to one another using the power cable input and output sockets.

**NOTE: USE CAUTION WHEN POWER LINKING OTHER FIXTURES AS THE POWER CONSUMPTION OF OTHER MODEL FIXTURES MAY EXCEED THE MAX POWER OUTPUT ON THIS FIXTURE! CHECK SILK SCREEN FOR MAX AMPS.**

## Focus Spot 4Z

## Trouble Shooting

Listed below are a few common problems the user may encounter, with solutions.

### **Unit not responding to DMX:**

1. Check that the DMX cables are connected properly and are wired correctly (pin 3 is “hot”; on some other DMX devices pin 2 may be ‘hot’). Also, check that all cables are connected to the right connectors; it does matter which way the inputs and outputs are connected.

## Focus Spot 4Z

## Cleaning

Due to fog residue, smoke, and dust cleaning the internal and external optical lenses must be carried out periodically to optimize light output.

1. Use normal glass cleaner and a soft cloth to wipe down the outside casing.
  2. Clean the external optics with glass cleaner and a soft cloth every 20 days.
  3. Always be sure to dry all parts completely before plugging the unit back in.
- Cleaning frequency depends on the environment in which the fixture operates (i.e. smoke, fog residue, dust, dew).



**MANUFACTURER'S LIMITED WARRANTY**

- A. ADJ Products, LLC hereby warrants, to the original purchaser, ADJ Products, LLC products to be free of manufacturing defects in material and workmanship for a prescribed period from the date of purchase (see specific warranty period on reverse). This warranty shall be valid only if the product is purchased within the United States of America, including possessions and territories. It is the owner's responsibility to establish the date and place of purchase by acceptable evidence, at the time service is sought.
- B. For warranty service you must obtain a Return Authorization number (RA#) before sending back the product—please contact ADJ Products, LLC Service Department at 800-322-6337. Send the product only to the ADJ Products, LLC factory. All shipping charges must be pre-paid. If the requested repairs or service (including parts replacement) are within the terms of this warranty, ADJ Products, LLC will pay return shipping charges only to a designated point within the United States. If the entire instrument is sent, it must be shipped in its original package. No accessories should be shipped with the product. If any accessories are shipped with the product, ADJ Products, LLC shall have no liability whatsoever for loss of or damage to any such accessories, nor for the safe return thereof.
- C. This warranty is void if the serial number has been altered or removed; if the product is modified in any manner which ADJ Products, LLC concludes, after inspection, affects the reliability of the product; if the product has been repaired or serviced by anyone other than the ADJ Products, LLC factory unless prior written authorization was issued to purchaser by ADJ Products, LLC; if the product is damaged because not properly maintained as set forth in the instruction manual.
- D. This is not a service contract, and this warranty does not include maintenance, cleaning or periodic check up. During the period specified above, ADJ Products, LLC will replace defective parts at its expense with new or refurbished parts, and will absorb all expenses for warranty service and repair labor by reason of defects in material or workmanship. The sole responsibility of ADJ Products, LLC under this warranty shall be limited to the repair of the product, or replacement thereof, including parts, at the sole discretion of ADJ Products, LLC. All products covered by this warranty were manufactured after August 15, 2012, and bear identifying marks to that effect.
- E. ADJ Products, LLC reserves the right to make changes in design and/or improvements upon its products without any obligation to include these changes in any products theretofore manufactured.

No warranty, whether expressed or implied, is given or made with respect to any accessory supplied with products described above. Except to the extent prohibited by applicable law, all implied warranties made by ADJ Products, LLC in connection with this product, including warranties of merchantability or fitness, are limited in duration to the warranty period set forth above. And no warranties, whether expressed or implied, including warranties of merchantability or fitness, shall apply to this product after said period has expired. The consumer's and/or Dealer's sole remedy shall be such repair or replacement as is expressly provided above; and under no circumstances shall ADJ Products, LLC be liable for any loss or damage, direct or consequential, arising out of the use of, or inability to use, this product.

This warranty is the only written warranty applicable to ADJ Products, LLC Products and supersedes all prior warranties and written descriptions of warranty terms and conditions heretofore published.

**MANUFACTURER'S LIMITED WARRANTY PERIODS:**

- **Non L.E.D. Lighting Products = 1-year (365 days) Limited Warranty** (Such as: Special Effect Lighting, Intelligent Lighting, UV lighting, Strobes, Fog Machines, Bubble Machines, Mirror Balls, Par Cans, Trussing, Lighting Stands etc. excluding LED and lamps)
- **Laser Products = 1 Year (365 Days) Limited Warranty** (excluding laser diodes which have a 6 month limited warranty)
- **L.E.D. Products = 2-year (730 days) Limited Warranty** (excluding batteries which have a 180 day limited warranty). **Note: 2 Year Warranty only applies to purchases within the United States.**
- **StarTec Series = 1 Year Limited Warranty** (excluding batteries which have a 180 day limited warranty).
- **ADJ DMX Controllers = 2 Year (730 Days) Limited Warranty**

**Model: Focus Spot 4Z**

Voltage:	100V ~ 240V/50~60Hz
LEDs:	1 x 200W LED
Working Position:	Any safe working position
Power Draw:	256W
Fuse:	3A
Dimensions:	7.15" (L) x 10.97" (W) x 18" (H) 181.5 x 278.61 x 457.4mm
Weight:	23lbs. / 10 kgs
Colors:	8 Colors + White
Gobos:	6 Gobos + Open Inner Diameter: 19mm Outer Diameter: 23mm Thickness: 0.5mm
DMX Channels:	3 DMX Modes: 16/18/22
Warranty:	2 Year (730 days)

**Please Note:** Specifications and improvements in the design of this unit and this manual are subject to change without any prior written notice.