



ENCORE PROFILE PRO COLOR

User Instructions

©2023 ADJ Products, LLC all rights reserved. Information, specifications, diagrams, images, and instructions herein are subject to change without notice. ADJ Products, LLC logo and identifying product names and numbers herein are trademarks of ADJ Products, LLC. Copyright protection claimed includes all forms and matters of copyrightable materials and information now allowed by statutory or judicial law or hereinafter granted. Product names used in this document may be trademarks or registered trademarks of their respective companies and are hereby acknowledged. All non-ADJ Products, LLC brands and product names are trademarks or registered trademarks of their respective companies.

ADJ Products, LLC and all affiliated companies hereby disclaim any and all liabilities for property, equipment, building, and electrical damages, injuries to any persons, and direct or indirect economic loss associated with the use or reliance of any information contained within this document, and/or as a result of the improper, unsafe, insufficient and negligent assembly, installation, rigging, and operation of this product.

ADJ PRODUCTS LLC World Headquarters

6122 S. Eastern Ave. | Los Angeles, CA 90040 USA

Tel: 800-322-6337 | Fax: 323-582-2941 | www.adj.com | lsupport@adj.com

ADJ Supply Europe B.V.

Junostraat 2 | 6468 EW Kerkrade | Netherlands

Tel: +31 45 546 85 00 | Fax: +31 45 546 85 99 | www.americandj.eu | service@americandj.eu

Europe Energy Saving Notice

Energy Saving Matters (EuP 2009/125/EC)

Saving electric energy is a key to help protecting the environment. Please turn off all electrical products when they are not in use. To avoid power consumption in idle mode, disconnect all electrical equipment from power when not in use. Thank you!

DOCUMENT VERSION



Due to additional product features and/or enhancements, an updated version of this document may be available online.

Please check www.adj.com for the latest revision/update of this manual before beginning installation and/or programming.

Date	Document Version	Software Version >	DMX Channel Mode	Notes
07/23/2020	1.0	V1.04	2/4/13/14/16	Initial Release
08/09/2021	1.1	N/C	N/C	Updated Specifications
12/15/2020	1.2	V1.06	N/C	Corrected DMX Traits, added Color Temperature Table
08/09/2021	1.3	N/C	N/C	Updated Specifications, added FCC Statement
10/01/2021	1.4	N/C	N/C	Updated System Menu and DMX Traits, Added Color Macros Chart
6/01/2022	1.5	V1.1.9	2/4/6/13/14/16	Updated System Menu, & added CH6 mode
07/20/2022	1.6	N/C	N/C	Added RDM Parameters and Codes
01/30/2023	1.7	N/C	N/C	Added Accessory Installation Guidelines; updated Installation, Specifications, Optional Accessories
02/06/2023	1.8	N/C	N/C	Corrected Optional Accessories
06/02/2023	1.9	N/C	N/C	Corrected System Menu

CONTENTS

Introduction	4
Warranty Information	5
Safety Guidelines	7
Overview	8
Installation	9
Accessory Installation	12
RDM Parameters	14
System Menu	15
Dimmer Modes / Curves	18
DMX Setup	19
DMX Channels & Traits	20
Color Temperature Chart	23
Color Macros Chart	24
Troubleshooting / Cleaning / Maintenance	25
Specifications	26
Dimensions	27
Optional Accessories	31

INTRODUCTION

Unpacking: Thank you for purchasing the Encore Profile Pro Color by ADJ Products, LLC. Every Encore Profile Pro Color has been thoroughly tested and has been shipped in perfect operating condition. Carefully check the shipping carton for damage that may have occurred during shipping. If the carton appears to be damaged, carefully inspect your fixture for any damage and be sure all accessories necessary to operate the unit has arrived intact. In the event that damage has been found or parts are missing, please contact our toll free customer support number for further instructions. Do not return this unit to your dealer without first contacting customer support.

Introduction: The ADJ Encore Profile Pro Color is a DMX intelligent, high powered LED fixture. To optimize the performance of this product, please read these operating instructions carefully to familiarize yourself with the basic operations of this unit. These instructions contain important safety information regarding the use and maintenance of this unit. Please keep this manual with the unit for future reference.

Customer Support: Contact ADJ Service for any product related service and support needs. Also visit forums.adj.com with questions, comments or suggestions.

Parts: To purchase parts online visit:
<http://parts.adj.com> (US)
<http://www.adjparts.eu> (EU)

ADJ SERVICE USA - Monday - Friday 8:00am to 4:30pm PST
Voice: 800-322-6337 | Fax: 323-582-2941 | support@adj.com

ADJ SERVICE EUROPE - Monday - Friday 08:30 to 17:00 CET
Voice: +31 45 546 85 60 | Fax: +31 45 546 85 96 | support@adj.eu

ADJ PRODUCTS LLC USA
6122 S. Eastern Ave. Los Angeles, CA. 90040
323-582-2650 | Fax 323-532-2941 | www.adj.com | info@adj.com

ADJ SUPPLY Europe B.V
Junostraat 2 6468 EW Kerkrade, The Netherlands
+31 (0)45 546 85 00 | Fax +31 45 546 85 99
www.adj.eu | info@adj.eu

ADJ PRODUCTS GROUP Mexico
AV Santa Ana 30 Parque Industrial Lerma, Lerma, Mexico 52000
+52 (728) 282-7070

CAUTION! There are no user serviceable parts inside this unit. Do not attempt any repairs yourself, as doing so will void your manufacturer's warranty. In the unlikely event your unit may require service, please contact ADJ Products, LLC.

Do not discard the shipping cartoon in the trash. Please recycle when ever possible.

LIMITED WARRANTY (USA ONLY)

- A. ADJ Products, LLC hereby warrants, to the original purchaser, ADJ Products, LLC products to be free of manufacturing defects in material and workmanship for a prescribed period from the date of purchase (see specific warranty period on reverse). This warranty shall be valid only if the product is purchased within the United States of America, including possessions and territories. It is the owner's responsibility to establish the date and place of purchase by acceptable evidence, at the time service is sought.
- B. For warranty service, you must obtain a Return Authorization number (RA#) before sending back the product-please contact ADJ Products, LLC Service Department at 800-322-6337. Send the product only to the ADJ Products, LLC factory. All shipping charges must be pre-paid. If the requested repairs or service (including parts replacement) are within the terms of this warranty, ADJ Products, LLC will pay return shipping charges only to a designated point within the United States. If the entire instrument is sent, it must be shipped in its original package. No accessories should be shipped with the product. If any accessories are shipped with the product, ADJ Products, LLC shall have no liability whatsoever for loss of or damage to any such accessories, or for the safe return thereof.
- C. This warranty is void if the serial number has been altered or removed; if the product is modified in any manner which ADJ Products, LLC concludes, after inspection, affects the reliability of the product, if the product has been repaired or service by anyone other than ADJ Products, LLC factory unless prior written authorization was issued to purchaser by ADJ Products, LLC; if the product is damaged because not properly maintained as set forth in the instruction manual.
- D. This is not a service contract, and this warranty does not include maintenance, cleaning or periodic check up. During the period specified above, ADJ Products, LLC will replace defective parts at its expense with new or refurbished parts, and will absorb all expenses for warranty service and repair labor by reason of defects in material or workmanship. The sole responsibility of ADJ Products, LLC under this warranty shall be limited to the repair of the product, or replacement thereof, including parts, at the sole discretion of ADJ Products, LLC. All products covered by this warranty were manufactured after August 15, 2012, and bear identifying marks to that effect.
- E. ADJ Products, LLC reserves the right to make changes in design and/or improvements upon its products without any obligation to include these changes in any products theretofore manufactured.
- F. No warranty, whether expressed or implied, is given or made with respect to any accessory supplied with products described above. Except to the extent prohibited by applicable law, all implied warranties made by ADJ Products, LLC in connection with this product, including warranties of merchantability or fitness, are limited in duration to the warranty period set forth above. And no warranties, whether expressed or implied, including warranties of merchantability or fitness, shall apply to this product after said period has expired. The consumer's and/or Dealer's sole remedy shall be such repair or replacement as is expressly provided above; and under no circumstances shall ADJ Products, LLC be liable for any loss or damage, direct or consequential, arising out of the use of, or inability to use, this product.
- G. This warranty is the only written warranty applicable to ADJ Products, LLC Products and supersedes all prior warranties and written descriptions of warranty terms and conditions heretofore published.

LIMITED WARRANTY PERIODS

- **Non L.E.D. Lighting Products = 1-year (365 days) Limited Warranty** (Such as: Special Effect Lighting, Intelligent Lighting, UV lighting, Strobes, Fog Machines, Bubble Machines, Mirror Balls, Par Cans, Trussing, Lighting Stands etc. excluding LED and lamps)
- **Laser Products = 1 Year (365 Days) Limited Warranty** (excludes laser diodes which have 6 month limited warranty)
- **L.E.D. Products = 2-year (730 days) Limited Warranty** (excluding batteries which have a 180 day limited warranty)
Note: 2 Year Warranty only applies to purchases within the United States.
- **StarTec Series = 1 Year Limited Warranty** (excluding batteries which have a 180 day limited warranty)
- **ADJ DMX Controllers = 2 Year (730 Days) Limited Warranty**

WARRANTY REGISTRATION

The Encore Profile Pro Color carries a 2 year limited warranty. Please fill out the enclosed warranty card to validate your purchase. All returned service items, whether under warranty or not, must be freight pre-paid and accompanied by a return authorization (R.A.) number. The R.A. number must be clearly written on the outside of the return package. A brief description of the problem as well as the R.A. number must also be written down on a piece of paper included in the shipping carton. If the unit is under warranty, you must provide a copy of your proof of purchase invoice. You may obtain an R.A. number by contacting our customer support team on our customer support number. All packages returned to the service department not displaying an R.A. number on the outside of the package will be returned to the shipper.

FEATURES

The Encore Profile Pro Color Ellipsoidal features a 250W RGBWAL (Red, Green, Blue, White, Amber, Lime) LED engine, >90CRI with 14°, 19°, 26°, 36°, and 50° interchangeable high definition lens options (sold separately), (4) blade manual framing shutters, manual focus, supports B size metal HT transparency gobos, DMX controlled electronic strobe, dimming, dimming curves and dimming modes, flicker free operation for TV and FILM, adjustable refresh rate frequency, locking 5-pin XLR In/Out connectors and Locking Power Input, (4) button LCD control display panel, an integrated rigging yoke, quiet fan cooling, and a multi-voltage universal auto switching power supply (AC100-240v).

The Encore Profile Pro Color has an independent dynamic white fader feature that achieves white color temperatures from 2400K to 9000K.

SAFETY GUIDELINES

THIS FIXTURE IS COMPOSED OF SOPHISTICATED ELECTRONIC COMPONENTS. TO GUARANTEE SMOOTH OPERATION, IT IS IMPORTANT TO FOLLOW ALL INSTRUCTIONS AND GUIDELINES IN THIS MANUAL. ADJ PRODUCTS, LLC IS NOT RESPONSIBLE FOR INJURY AND/OR DAMAGES RESULTING FROM THE MISUSE OF THIS FIXTURE DUE TO THE DISREGARD OF THE INFORMATION PRINTED IN THIS MANUAL. ONLY QUALIFIED AND/OR CERTIFIED PERSONNEL SHOULD PERFORM INSTALLATION OF THIS FIXTURE AND ONLY THE ORIGINAL RIGGING PARTS INCLUDED WITH THIS FIXTURE SHOULD BE USED FOR INSTALLATION. ANY MODIFICATIONS TO THE FIXTURE AND/OR CERTIFIED PERSONNEL SHOULD PERFORM INSTALLATION OF THIS FIXTURE AND/OR THE INCLUDED MOUNTING HARDWARE WILL VOID THE ORIGINAL MANUFACTURER'S WARRANTY AND INCREASE THE RISK OF DAMAGE AND/OR PERSONAL INJURY.

- **PROTECTION CLASS 1 - FIXTURE MUST BE PROPERLY GROUNDED**
- **THERE ARE NO USER SERVICEABLE PARTS INSIDE THIS UNIT.**
- **DONOT ATTEMPT ANY REPAIRS YOURSELF; DOING SO WILL VOID YOUR MANUFACTURER'S WARRANTY. DAMAGES RESULTING FROM MODIFICATIONS TO THIS FIXTURE AND/OR THE DISREGARD OF SAFETY INSTRUCTIONS AND GUIDELINES IN THIS MANUAL VOID THE MANUFACTURE'S WARRANTY AND ARE NOT SUBJECT TO ANY WARRANTY CLAIMS AND/OR REPAIRS.**
- **DO NOT PLUG FIXTURE INTO A DIMMER PACK!**
- **NEVER OPEN THIS FIXTURE WHILE IN USE!**
- **UNPLUG POWER BEFORE SERVICING FIXTURE!**
- **NEVER TOUCH FIXTURE DURING OPERATION, AS IT MAY BE HOT!**
- **KEEP FLAMMABLE MATERIALS AWAY FROM FIXTURE!**
- **NEVER LOOK DIRECTLY INTO THE LIGHT SOURCE!**
- **RETINA INJURY RISK - MAY INDUCE BLINDNESS!**
- **SENSITIVE PERSONS MAY SUFFER AN EPILEPTIC SHOCK!**
- **INDOOR / DRY LOCATIONS USE ONLY!**
- **DO NOT EXPOSE FIXTURE TO RAIN AND MOISTURE!**
- **MINIMUM DISTANCE TO OBJECTS/SURFACES**
- **MUST BE 6.6 FEET (2 METERS)**
- **MAXIMUM TEMP OF EXTERNAL SURFACE 185° F (85°C)**
- **MINIMUM DISTANCE OF INFLAMMABLE MATERIALS**
- **FROM THE SURFACE 1.6 FEET (0.5 METER)**
- **DO NOT TOUCH** the fixture housing during operation. Turn OFF the power and allow approximately 60 minutes for the fixture to cool down before serving.
- **DO NOT** shake fixture, avoid brute force when installing and/or operating fixture.
- **DO NOT** operate fixture if the power cord is frayed, crimped, damaged and/or if any of the power cord connectors are damaged and do not insert into the fixture securely with ease. **NEVER** force a power cord connector into the fixture. If the power cord or any of its connectors are damaged, replace it immediately with a new one of similar power rating.
- **DO NOT** block any air ventilation slots. All fan and air inlets must remain clean and never blocked. Allow approx. 6" (15cm) between fixture and other devices or a wall for proper cooling.
- When installing fixture in a suspended environment, always use mounting hardware that is no less than M10 x 25 mm, and always install fixture with an appropriately rated safety cable.
- Always disconnect fixture from main power source before performing any type of service and/or cleaning procedure. Only handle the power cord by the plug end, never pull out the plug by tugging the wire portion of the cord.
- During the initial operation of this fixture, a light smoke or smell may emit from the interior of the fixture. This is a normal process and is caused by excess paint in the interior of the casing burning off from the heat associated with the lamp and will decrease gradually over time.
- Consistent operational breaks will ensure fixture will function properly for many years.
- **ONLY** Use original packaging and materials to transport the fixture in for service.

OVERVIEW

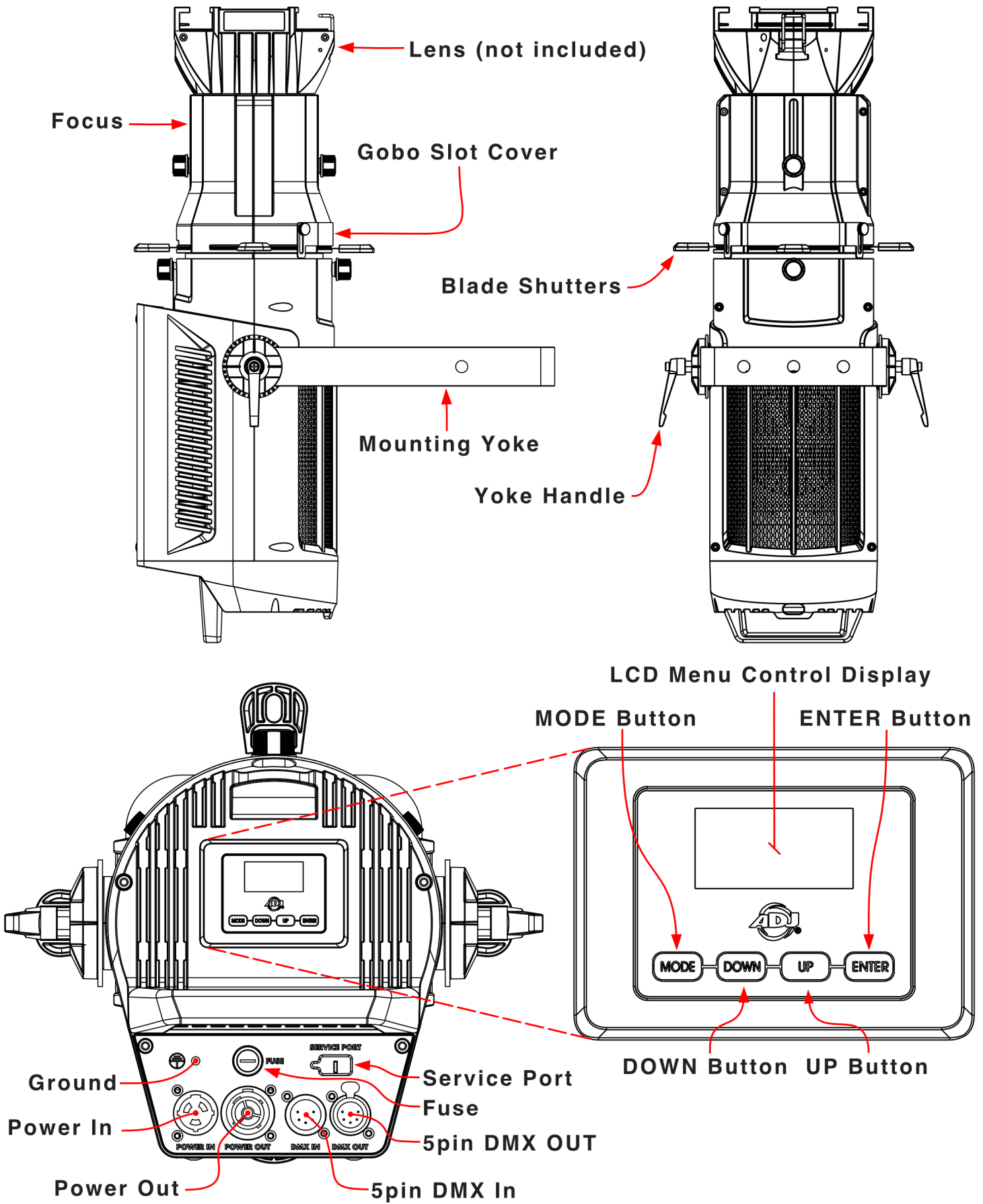

INSTALLATION



FLAMMABLE MATERIAL WARNING

Keep fixture at least 7.9in. (0.2m) away from any flammable materials, decorations, pyrotechnics, etc.



ELECTRICAL CONNECTIONS

A qualified electrician should be used for all electrical connections and/or installations.



MINIMUM DISTANCE TO OBJECTS/SURFACES MUST BE 40 FEET (12 METERS)



MAXIMUM TEMPERATURE OF EXTERNAL SURFACE 167°F (75°C)

DO NOT INSTALL THE FIXTURE IF YOU ARE NOT QUALIFIED TO DO SO!

Fixture **MUST** be installed following all local, national, and country commercial electrical and construction codes and regulations. Before rigging/mounting the fixture to any metal truss/structure or placing the fixture on any surface, a professional equipment installer **MUST** be consulted to determine if the metal truss/structure or surface is properly certified to safely hold the combined weight of the fixture, clamps, cables, and accessories.

Overhead fixture installation must always be secured with a secondary safety attachment, such as an appropriately rated safety cable that meets all local, national, and country codes and regulations.

Fixture ambient operating temperature range is **-14°F to 113°F. (-10°C to 45°C)**

Do not use this fixture outside this temperature range.

Fixture should be installed in areas outside walking paths, seating areas, or away from areas where unauthorized personnel might reach the fixture by hand.

NEVER stand directly below the fixture when rigging, removing, or servicing.

Allow approximately 15-minutes for the fixture to cool down before servicing.

RIGGING

Overhead rigging requires extensive experience, including among others calculating working load limits, installation material being used, and periodic safety inspection of all installation material and the fixture. If you lack these qualifications, do not attempt the installation yourself. Improper installation can result in bodily injury.



ALWAYS ATTACH AN APPROPRIATELY RATED SAFETY CABLE (NOT INCLUDED) THAT MEETS ALL LOCAL, NATIONAL, AND COUNTRY CODES AND REGULATIONS WHENEVER INSTALLING FIXTURE IN A SUSPENDED ENVIRONMENT!



WARNING

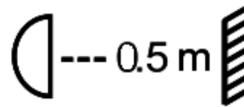

Minimum distance to lighted objects 0.5 meters.

Minimum distance of inflammable materials from the surface 0.5m.

INSTALLATION

Always ensure that the unit is firmly fixed to avoid vibration and slipping while operating. Always ensure that the structure to which you are attaching the unit is secure and is able to support a weight of 10 times the unit's weight. **Always** use safety cables that can hold 12 times the weight of the unit when installing the fixture. This equipment must be installed by a professional, and it must be installed in a place where it is out of the reach of people's grasp.

The Encore Profile Pro Color is fully operational in three different mounting positions; hanging upside-down, mounted sideways on trussing, or set on a flat level surface. **Please note that if the optional iris accessory has been installed, the unit can only be installed in an upright position with the iris handle facing upward, in order to prevent the iris from accidentally falling out.** Be sure this fixture is kept at least 12m (40ft) away from any flammable materials (decoration etc.).

OVERHEAD RIGGING: The Encore Profile Pro Color includes two rigging options.

1) OMEGA BRACKET - Mount the fixture with an appropriately rated professional grade rigging clamp (not included) to the included Omega Bracket using an M12 screw and nut (not included). With the rigging clamp securely attached to the Omega Bracket, attach the Omega Bracket to the fixture by inserting both of the 1/4-turn quick-lock fasteners into the aligning holes on the fixture yoke bracket, and turning each clockwise to secure.

MAKE SURE THE OMEGA BRACKET IS SECURELY ATTACHED BEFORE RIGGING FIXTURE!

2) MOUNTING YOKE - Mount the fixture with an appropriately rated professional grade rigging clamp (not included) to the fixture yoke bracket center hole using an M12 screw and nut (not included). **MAKE SURE THE CLAMP IS SECURELY ATTACHED BEFORE RIGGING FIXTURE!**

SAFETY CABLE: Pull the safety-cable through the opening located on the rear of the unit and over the trussing system or a safe fixation spot. Insert the end in the carabiner and tighten the safety screw. **Always** use and install a safety cable as a safety measure to prevent accidental damage and/or injury in the event the clamp fails.

CLAMP INSTALLATION

When mounting fixture to truss, be sure to secure an appropriately rated professional grade rigging clamp to either the included **Omega Brackets** using an M10 screw fitted through the center hole of the **Omega Brackets**, or to the **Mounting Yoke**. The fixture provides a built-in rigging point for a **SAFETY CABLE** (not included). Be sure to only use one of the designated rigging point for the safety cable and never secure a safety cable to the carrying handle.

*SAFETY CABLE

ALWAYS ATTACH A SAFETY CABLE WHENEVER INSTALLING THIS FIXTURE IN A SUSPENDED ENVIRONMENT TO ENSURE THE FIXTURE WILL NOT DROP IF THE CLAMP FAILS. The Safety Cable must be attached to the fixture and routed around the truss, or other secure fixation point, and both ends securely affixed to the carabiner attached at the built-in rigging points.

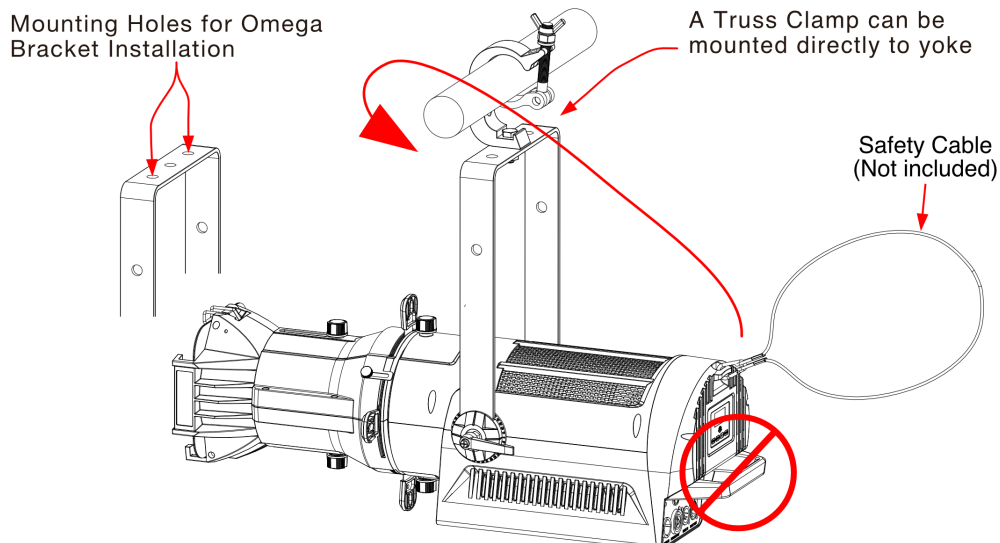

INSTALLATION

POTENTIAL INTERNAL FIXTURE DAMAGE FROM EXTERNAL SOURCES OF LIGHT BEAMS

External sources of light beams from direct sunlight, lighting moving head fixtures, and lasers, which are focused directly towards the exterior housing and/or penetrate the front lens opening of ADJ lighting fixtures, can cause severe internal damage including burning to optics, dichroic color filters, glass and metal gobos, prisms, animation wheels, frost filters, iris, shutters, motors, belts, wiring, discharge lamps, and LEDs.

This issue is not specific to ADJ lighting fixtures, it is a common issue with lighting fixtures from all manufacturers. Although there is no true way to fully prevent this issue from happening, the following guidelines can prevent any potential damage from occurring if followed. Contact ADJ Service for more details.

DO NOT EXPOSE THE FIXTURE AND/OR FRONT LENS OPENING TO LIGHT BEAMS FROM DIRECT SUNLIGHT, OTHER LIGHTING MOVING HEAD FIXTURES, AND LASERS WHILE UNPACKING, INSTALLATION, USE, AND EXTENDED IDLE TIMES OUTDOORS. DO NOT FOCUS A LIGHT BEAM FROM ONE LIGHTING FIXTURE DIRECTLY TOWARDS ANOTHER.

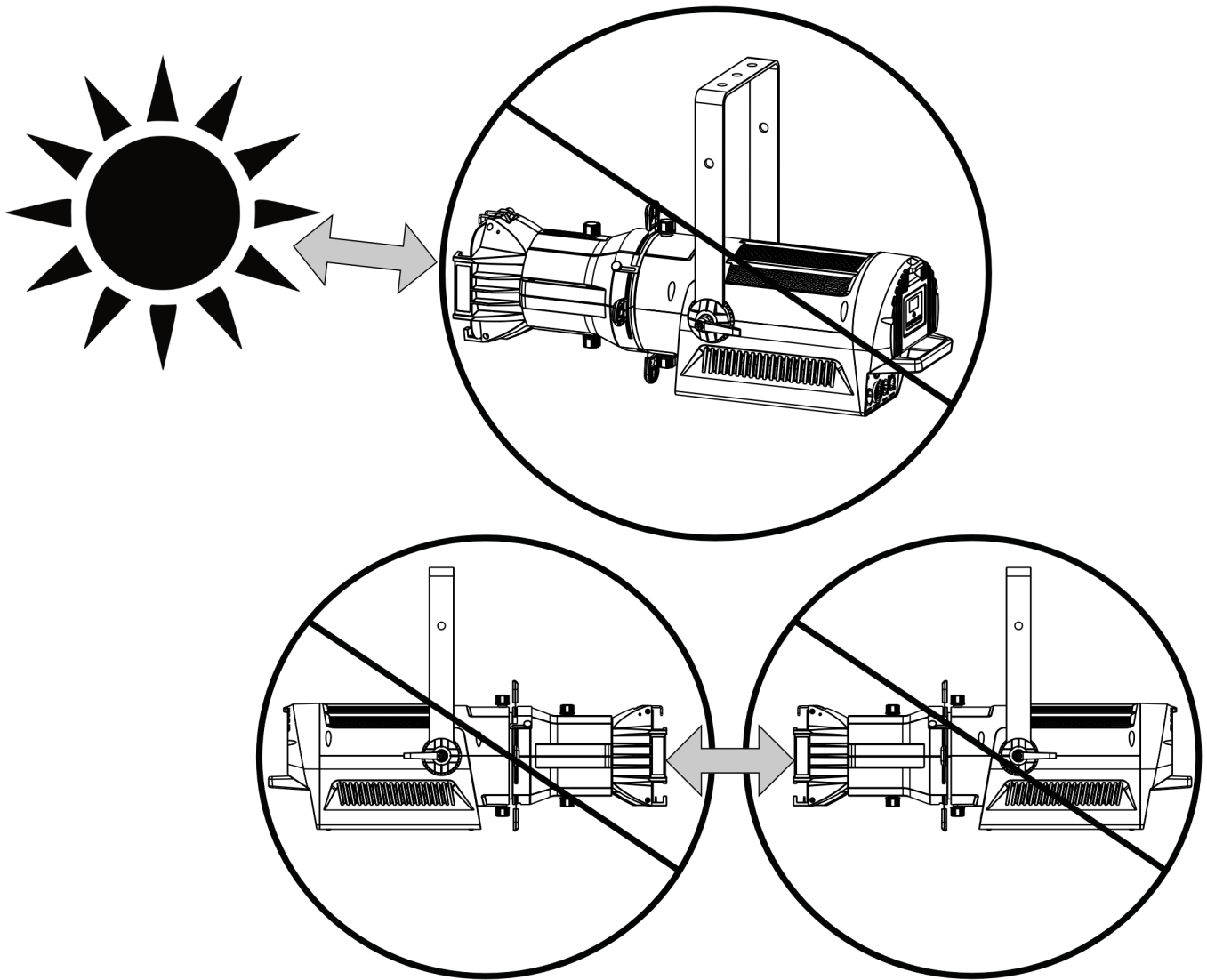

ACCESSORY INSTALLATION

LENS AND GOBO

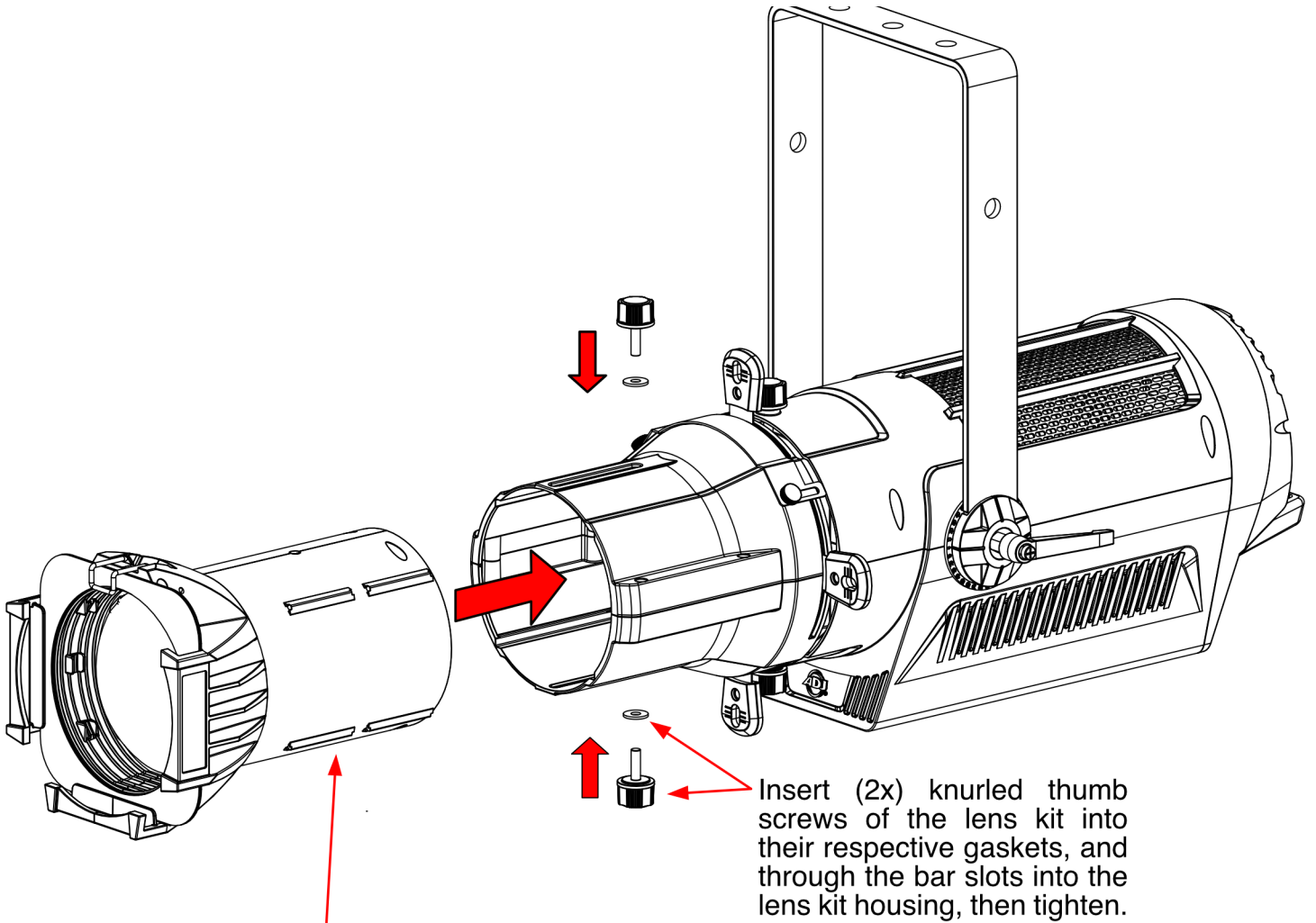

Insert the lens kit (not included) into the lens cone inside.

Insert (2x) knurled thumb screws of the lens kit into their respective gaskets, and through the bar slots into the lens kit housing, then tighten.



Gobo Holder

To install Gobo Holder, loosen the (2x) thumb screws of Gobo Holder Slot Cover and slide it forward.

ACCESSORY INSTALLATION

IRIS

Follow the steps below to install the optional iris accessory. **Please note that when the iris is installed, the fixture should only be mounted in an upright orientation with the iris handle pointing upwards, to reduce the risk of the iris falling out.**

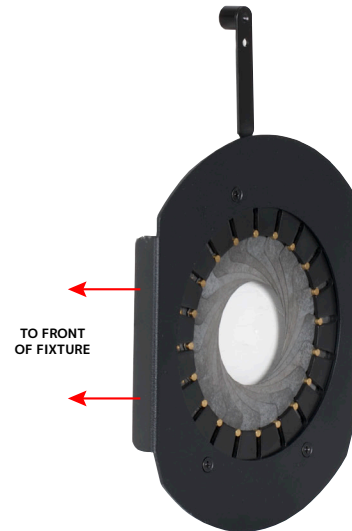

1. Locate the iris cover plate at the top of the fixture, just forward of the blade shutters. Loosen (but do not completely remove) the two thumb screws that hold the plate in place, then slide the cover plate forward to expose the iris slot.

2. Orient the iris so that the tabs along the side are facing toward the front of the fixture, as shown above.



3. Slide the iris down into the iris slot. Ensure that the tabs on the side of the iris are facing toward the front of the fixture.



4. Slide the plate back to cover the iris slot, and tighten the thumb screws to secure in place. The plate should be in contact with the handle of the iris, but be careful not to push the plate too tightly against the handle. Do not overtighten the thumb screws.

RDM PARAMETERS

NOTE: In order for RDM to work properly, RDM enabled equipment must be used throughout the entire system, including DMX data splitters and wireless systems.

Remote Device Management (RDM) is a protocol that sits on top of the DMX512 data standard for lighting, and allows the DMX systems of the fixtures to be modified and monitored remotely. This protocol is ideal for instances in which a unit is installed in a location that is not easily accessible.

With RDM, the DMX512 system becomes bi-directional, allowing a compatible RDM enabled controller to send out a signal to devices on the wire, as well as allowing the fixture to respond (known as a GET command). The controller can then use its SET command to modify settings that would typically have to be changed or viewed directly via the unit's display screen, including the DMX Address, DMX Channel Mode, and Temperature Sensors.

FIXTURE RDM INFORMATION:

Device ID	Device Model ID	RDM Code	Personality ID
000E-FFFF	14	0X1900	001 02CH 002 04CH 003 13CH 004 14CH 005 16CH 006 06CH

Please be aware that **not all RDM devices support all RDM features**, and therefore it is important to check beforehand to ensure that the equipment that you are considering includes all of the features that you require.

The following parameters are accessible in RDM on this device:

[0x0011] Proxied Device Count	[0x0032] Clear Status ID	[0x0603] Realtime Clock
[0x0200] Sensor Definition	[0x0401] Lamp Hours	[0x1010] Power State
[0x0201] Sensor Value	[0x0402] Lamp Strikes	[0x1031] Preset Playback
[0x0080] Device Model Description	[0x0403] Lamp State	[0x0122] Default Slot Value
[0x0081] Manufacturer Label	[0x0404] Lamp Mode	[0x00B0] Language
[0x0082] Device Label	[0x0405] Device Power Cycles	[0x00A0] Language Capabilities
[0x00E0] DMX Personality	[0x0600] Pan Invert	[0x00C2] Boot Software Version Label
[0x00E1] DMX Personality Description	[0x0601] Tilt Invert	[0x00C1] Boot Software Version ID
[0x0400] Device Hours	[0x0602] Pan Tilt Swap	[0x0070] Product Detail ID List
[0x0015] Comms Status	[0x0500] Display Invert	[0x0030] Status Messages
[0x0031] Status ID Description	[0x0501] Display Level	[0x1001] Reset Device

SYSTEM MENU

The fixture includes an easy to navigate system-menu control panel display where all necessary settings and adjustments are made. (See image below) During normal operation, pressing the MENU button once will access the fixture's main menu. Once in the main menu, you can navigate through the different menu's with the UP, DOWN, and MENU buttons. When you reach a field that requires adjusting, press the ENTER button to access that field and use the UP and DOWN buttons to adjust the field. Pressing the ENTER button once more to confirm your setting. You may exit the menu's at any time without making any adjustments by pressing the MENU button. If there are no changes/adjustments made within 10 seconds, the unit will revert back to the setting made under "No DMX State".

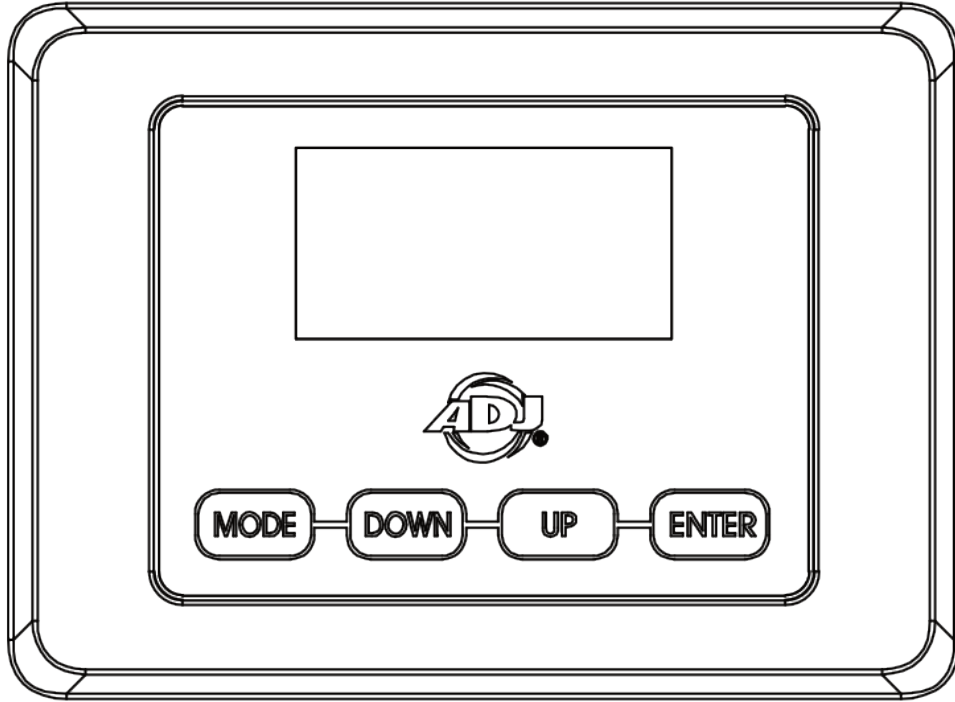

SERVICE PORT / SOFTWARE UPDATES

Please contact ADJ customer support for latest software and updating instructions

SYSTEM MENU

Supports Software Versions: 1.1.9

MENU	OPTIONS / VALUES (Default Settings BOLD)		DESCRIPTION	
DMX Address	001	001 - 512	Shall be used to set the units starting DMX address channel. Depending on set DMX mode, unit shall not allow to be addressed any higher that will not allow for all channels to be accessed from the console.	
DMX Channel Mode	2CH/4CH/6CH/ 13CH /14CH/16CH Note: When using 2 channel DMX mode, user must use the manual color and/or CCT channels to set the desired color.		Shall be used to set the units desired DMX mode.	
Personality	Status	Lost Dmx Black/Hold	No dmx status	
	LCD Set	Display	ON/OFF	30S blackout display
		Key Lock	ON/OFF	
		Flash	ON/OFF	No DMX Flash
		Invert	ON/OFF	Screen 180° flip
	Temp.C/F	C/F	Set temperature unit	
	Dim Mode	Standard		Standard mode
		Stage		Stage mode
		TV		TV mode
		Architec		Architectural mode
		Theatre		Theater mode
		Stage 2		Stage 2 mode
	Disp. Set	Address	Starting DMX Address	
		CHAN. VAL PrimSecd	Shall display last active DMX value primary / secondary	
	Dim Curve	Square		
		Linear		
		Inv. Squa S. Curve		
Frequen	900HZ, 1000HZ, 1100HZ, 1200HZ , 1300HZ, 1400HZ, 1500HZ, 2500HZ, 4000HZ, 5000HZ, 10KHZ, 15KHZ, 20KHZ, 25KHZ			
primarySw	ON/OFF		Primary transmit signal (should be on for primary & secondary)	
USB Data	ON/OFF			
DFSE	ON/OFF		Default Setting	
Manual Control	ManCtrl	Red=XXX		
		Green=XXX		
		Blue=XXX		
		White=XXX		
		Amber=XXX		
		Lime=XXX		
		Strobe=XXX		
		Dimmer=XXX		
		CCT=XXX		
		Tint=XXX		
Service	Calibrat	Password (50)		
		Red		
		Green		
		Blue		
		White		
		Amber		
Info	Time Info	Current	Current lamp running time (H)	
		Total	Total lamp running time (H)	
		Last	Last cleared machine running time	
		Password	Clear password (50/60)	
		Clear	ON/OFF	
	TempInfo	xxxF/xxxC		
	Err.Info	XXX		
	RDM UID	XXXXXX		
Modellnf	Encore Profile Pro Color			
Software	V1.1.9			

SYSTEM MENU

DMX Address - In this menu you can find and set your desired DMX address.

Channel Mode - In this menu you can find and set your desired DMX channel mode.

Function Status - This menu setting is used as a precaution mode in case the DMX signal is lost or interrupted. The operating mode chosen in this menu is the running mode the fixture will go into when the DMX signal is lost. Listed below are the 3 modes.

- **Hold** - This setting will have the fixture stay in the last DMX setup.
- **Black** - This setting will have the fixture automatically go into stand by mode.

LCD Set - In this menu you are able to activate/deactivate the display blackout and activate/deactivate the display lock.

Temp.C/F - Set temperature display between Celsius and Fahrenheit.

Dim Mode - In this menu you are able to select your desired dimmer mode and adjust the dimming speed time.

Disp. Set - In this menu you are able to activate/deactivate the display blackout and activate/deactivate the display lock.

Dim Curve - Set Dimming Curve

Frequen - Set fixture frequency.

primarySW - This transmits the DMX signal via a primary & secondary control hierarchy.

Service - In this menu you are able to access and adjust/change: the calibration (effect adjust) and restore the factory settings.

USB_Data - Turns USB data access on or off.

DFSE - Turns Default Setting on or off.

Time Info - Select between Current fixture running time and Fixture total running time. Only the Fixture Current fixture running time can be cleared

TempInfo - Displays fixture temperature.

Err.Info - Displays fixture error information.

Modellnf - Displays fixture information.

Software - Displays current software version.

ManCTRL - Manual Dimmer Control.

Strobe=XXXX - Test Strobe Effect.

Calibrate - Calibrate LED, password protected.

MULTIPLE UNIT POWER LINKING

With this feature you can connect the fixtures to one another using the power cable input and output sockets.

NOTE: USE CAUTION WHEN POWER LINKING OTHER FIXTURES AS THE POWER CONSUMPTION OF OTHER MODEL FIXTURES MAY EXCEED THE MAXIMUM POWER OUTPUT ON THIS FIXTURE! CHECK SILK SCREEN FOR MAXIMUM AMPERES.

DIMMER MODE CHART

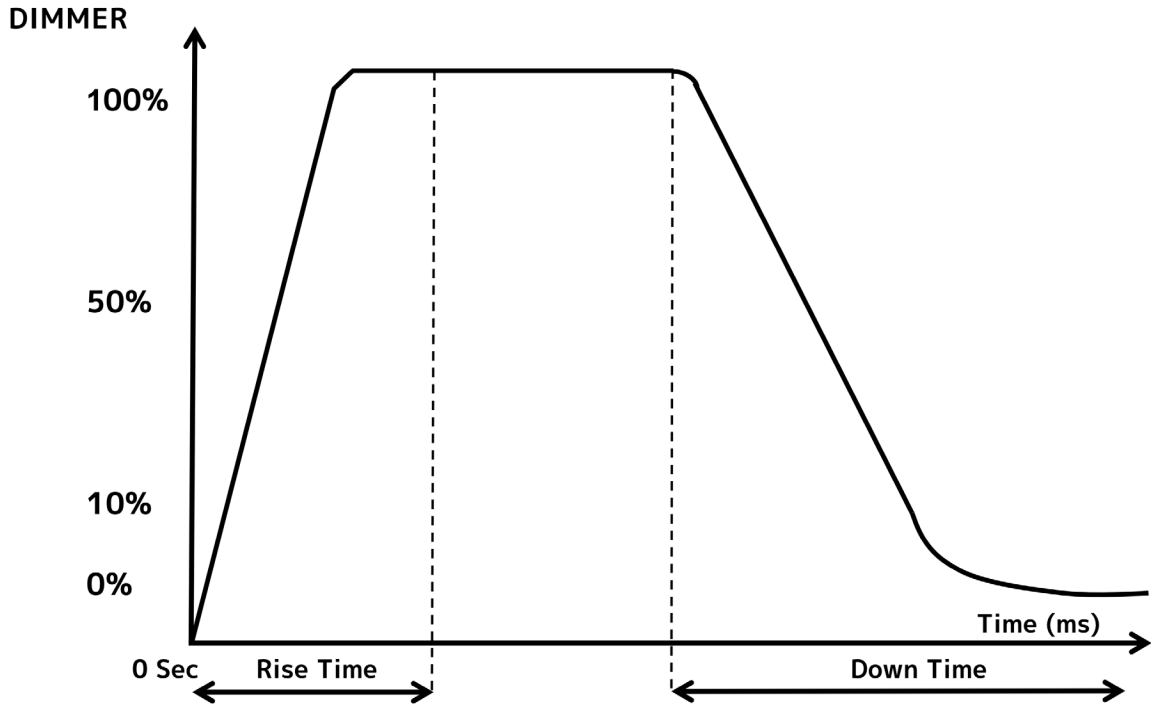

Dimming Curve Ramp Effect	0 sec Fade Time		1 sec Fade Time	
	Rise Time (ms)	Down Time (ms)	Rise Time (ms)	Down Time (ms)
Standard (default)	0	0	0	0
Stage	780	1100	1540	1660
TV	1180	1520	1860	1940
Architectural	1380	1730	2040	2120
Theatre	1580	1940	2230	2280

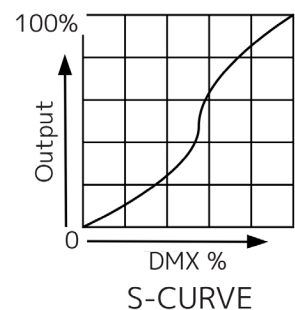
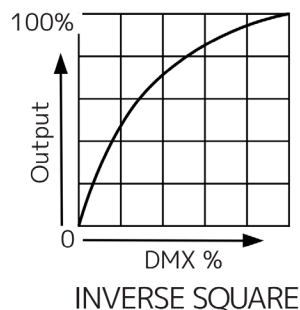
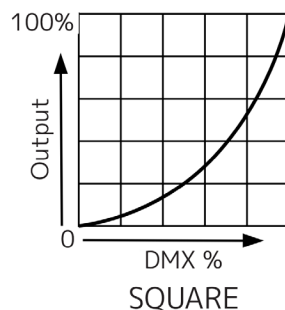
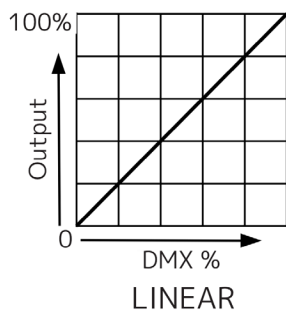

DMX SETUP

DMX-512: DMX is short for Digital Multiplex. This is a universal protocol used as a form of communication between intelligent fixtures and controllers. A DMX controller sends DMX data instructions from the controller to the fixture. DMX data is sent as serial data that travels from fixture to fixture via the DATA “IN” and DATA “OUT” XLR terminals located on all DMX fixtures (most controllers only have a DATA “OUT” terminal).

DMX Linking: DMX is a language allowing all makes and models of different manufactures to be linked together and operate from a single controller, as long as all fixtures and the controller are DMX compliant. To ensure proper DMX data transmission, when using several DMX fixtures try to use the shortest cable path possible. The order in which fixtures are connected in a DMX line does not influence the DMX addressing. For example; a fixture assigned a DMX address of 1 may be placed anywhere in a DMX line, at the beginning, at the end, or anywhere in the middle. When a fixture is assigned a DMX address of 1, the DMX controller knows to send DATA assigned to address 1 to that unit, no matter where it is located in the DMX chain.

Data Cable (DMX Cable) Requirements (For DMX Operation): The Encore Profile Pro Color can be controlled via DMX-512 protocol. The Encore Profile Pro Color has multiple DMX channel modes. Your unit and your DMX controller requires a 5-pin XLR connector for data input and data output. If you are making your own cables, be sure to use standard 110-120 Ohm shielded cable (This cable may be purchased at almost all pro lighting stores). Your cables should be made with a male and female XLR connector on either end of the cable. Also remember that DMX cable must be daisy chained and cannot be split.

Special Note: Line Termination. When longer runs of cable are used, you may need to use a terminator on the last unit to avoid erratic behavior. A terminator is a 110-120 ohm 1/4 watt resistor which is connected between pins 2 and 3 of a male XLR connector (DATA + and DATA -). This unit is inserted in the female XLR connector of the last unit in your daisy chain to terminate the line. Using a cable terminator (ADJ part number Z-DMX/T) will decrease the possibilities of erratic behavior.

DMX ADDRESSING

All fixtures should be given a DMX starting address when using a DMX controller, so the correct fixture responds to the correct control signal. This digital starting address is the channel number from which the fixture starts to “listen” to the digital control signal sent out from the DMX achieved by setting the correct DMX address on the digital control display on the fixture.

You can set the same starting address for all fixtures or a group of fixtures, or set different addresses for each individual fixture. Setting all fixtures to the same DMX address will cause all fixtures to react in the same way, in other words, changing the settings of one channel will affect all the fixtures simultaneously.

If you set each fixture to a different DMX address, each unit will start to “listen” to the channel number you have set, based on the quantity of DMX channels of each fixture. That means changing the settings of one channel will only affect the selected fixture.

DMX TRAITS: CHANNEL FUNCTIONS & VALUES

Supports Software Versions: ≥ 1.0.1A							
Features subject to change without notice.							
MODE/CHANNEL						VALUE	FUNCTION
2CH	4CH	6CH	13CH	14CH	16CH		
		1	1	1	1		Red
						000-255	0% - 100%
		2	2	2	2		Green
						000-255	0% - 100%
		3	3	3	3		Blue
						000-255	0% - 100%
		4	4	4	4		White
						000-255	0% - 100%
		5	5	5	5		Amber
						000-255	0% - 100%
		6	6	6	6		Lime
						000-255	0% - 100%
	1		7	7	7	000-255	COLOR TEMPERATURE LINEAR 2500K-1000K
							COLOR TEMPERATURE PRESETS
						000-031	No Function
	2		8	8	8	032-076	2700K
						077-121	3200K
						122-166	4000K
						167-211	5600K
						212-255	6500K
			9	9	9		COLOR TEMPERATURE RED to GREEN
						0	No Function
						001-255	Shift CT Red to Green
			10	10	10	000-255	64 Color Macros (See Color Macros Chart)
							Shutter
						000-031	Shutter Closed (LEDs OFF)
						032-063	Shutter OPEN (LEDs ON)
						064-095	Strobe effect slow to fast
			11	11	11	096-127	Shutter OPEN (LEDs ON)
						128-159	Pulse effect in sequences
						160-191	Shutter OPEN (LEDs ON)
						192-223	Random strobe effect slow to fast
						224-255	Shutter OPEN (LEDs ON)
						248-255	Open
1	3		12	12	12		Dimmer Intensity
						000-255	0 to 100%
2	4		13	13	13	000-255	Dimmer Fine 16bit

Supports Software Versions: ≥ 1.1.9

Features subject to change without notice.

MODE/CHANNEL						VALUE	FUNCTION
2CH	4CH	6CH	13CH	14CH	16CH		
				14	14		Dim Modes
						000-020	Standard
						021-040	Stage
						041-060	TV
						061-080	Architectural
						081-100	Theatre
						101-120	Stage 2
							Dimming Speed
						121	0.1 s
						122	0.2 s
						123	0.3 s
						124	0.4 s
						125	0.5 s
						126	0.6 s
						127	0.7 s
						128	0.8 s
						129	0.9 s
						130	1 s
						131	1.5 s
						132	2 s
						133	3 s
						134	4 s
						135	5 s
						136	6 s
				137	7 s		
				138	8 s		
				139	9 s		
				140	10 s		
				141-255	Default to Unit Setting		
				15		Dim Curves	
					000-020	Linear	
					021-040	Square	
					041-060	Inv. Squa	
					061-080	S. Curve	
					081-255	No Function	

Supports Software Versions: ≥ 1.1.9

Features subject to change without notice.

MODE/CHANNEL						VALUE	FUNCTION
2CH	4CH	6CH	13CH	14CH	16CH		
							LED Refresh Rates
						029-029	1080 Hz LED Refresh Rate
						030-030	1090 Hz LED Refresh Rate
						031-031	1100 Hz LED Refresh Rate
						032-032	1110 Hz LED Refresh Rate
						033-033	1120 Hz LED Refresh Rate
						034-034	1130 Hz LED Refresh Rate
						035-035	1140 Hz LED Refresh Rate
						036-036	1150 Hz LED Refresh Rate
						037-037	1160 Hz LED Refresh Rate
						038-038	1170 Hz LED Refresh Rate
						039-039	1180 Hz LED Refresh Rate
						040-040	1190 Hz LED Refresh Rate
						041-041	1210 Hz LED Refresh Rate
						042-042	1220 Hz LED Refresh Rate
						043-043	1230 Hz LED Refresh Rate
						044-044	1240 Hz LED Refresh Rate
						045-045	1250 Hz LED Refresh Rate
						046-046	1260 Hz LED Refresh Rate
						047-047	1270 Hz LED Refresh Rate
						048-048	1280 Hz LED Refresh Rate
						049-049	1290 Hz LED Refresh Rate
						050-050	1300 Hz LED Refresh Rate
						051-051	1310 Hz LED Refresh Rate
						052-052	1320 Hz LED Refresh Rate
						053-053	1330 Hz LED Refresh Rate
					16	054-054	1340 Hz LED Refresh Rate
						055-055	1350 Hz LED Refresh Rate
						056-056	1360 Hz LED Refresh Rate
						057-057	1370 Hz LED Refresh Rate
						058-058	1380 Hz LED Refresh Rate
						059-059	1390 Hz LED Refresh Rate
						060-060	1400 Hz LED Refresh Rate
						061-061	1410 Hz LED Refresh Rate
						062-062	1420 Hz LED Refresh Rate
						063-063	1430 Hz LED Refresh Rate
						064-064	1440 Hz LED Refresh Rate
						065-065	1450 Hz LED Refresh Rate
						066-066	1460 Hz LED Refresh Rate
						067-067	1470 Hz LED Refresh Rate
						068-068	1480 Hz LED Refresh Rate
						069-069	1490 Hz LED Refresh Rate
						070-070	1500 Hz LED Refresh Rate
						071-071	2500 Hz LED Refresh Rate
						072-072	4000 Hz LED Refresh Rate
						073-073	5000 Hz LED Refresh Rate
						074-074	6000 Hz LED Refresh Rate
						075-075	10K Hz LED Refresh Rate
						076-076	15K Hz LED Refresh Rate
						077-077	20K Hz LED Refresh Rate
						078-078	25K Hz LED Refresh Rate
						079-079	Disable LED Refresh Rate
						080-255	No Function

COLOR TEMPERATURE CHART

DMX VALUES	COLOR TEMPERATURE	DMX VALUES	COLOR TEMPERATURE	DMX VALUES	COLOR TEMPERATURE
000 - 024	No Function	057	5700K	090	9000K
025	2500K	058	5800K	091	9100K
026	2600K	059	5900K	092	9200K
027	2700K	060	6000K	093	9300K
028	2800K	061	6100K	094	9400K
029	2900K	062	6200K	095	9500K
030	3000K	063	6300K	096	9600K
031	3100K	064	6400K	097	9700K
032	3200K	065	6500K	098	9800K
033	3300K	066	6600K	099	9900K
034	3400K	067	6700K	100 - 255	10000K
035	3500K	068	6800K		
036	3600K	069	6900K		
037	3700K	070	7000K		
038	3800K	071	7100K		
039	3900K	072	7200K		
040	4000K	073	7300K		
041	4100K	074	7400K		
042	4200K	075	7500K		
043	4300K	076	7600K		
044	4400K	077	7700K		
045	4500K	078	7800K		
046	4600K	079	7900K		
047	4700K	080	8000K		
048	4800K	081	8100K		
049	4900K	082	8200K		
050	5000K	083	8300K		
051	5100K	084	8400K		
052	5200K	085	8500K		
053	5300K	086	8600K		
054	5400K	087	8700K		
055	5500K	088	8800K		
056	5600K	089	8900K		

COLOR MACRO CHART

Color	DMX Value	RGBW COLOR INTENSITY				Color	DMX Value	RGBW COLOR INTENSITY			
		RED	GREEN	BLUE	W/A			RED	GREEN	BLUE	WHITE
Off	0	0	0	0	0	Color Macro 33	129-132	255	206	143	0
Color Macro 1	1-4	80	255	234	80	Color Macro 34	133-136	254	177	153	0
Color Macro 2	5-8	80	255	164	80	Color Macro 35	137-140	254	192	138	0
Color Macro 3	9-12	77	255	112	77	Color Macro 36	141-144	254	165	98	0
Color Macro 4	13-16	117	255	83	83	Color Macro 37	145-148	254	121	0	0
Color Macro 5	17-20	160	255	77	77	Color Macro 38	149-152	176	17	0	0
Color Macro 6	21-24	223	255	83	83	Color Macro 39	153-156	96	0	11	0
Color Macro 7	25-28	255	243	77	77	Color Macro 40	157-160	234	139	171	0
Color Macro 8	29-32	255	200	74	74	Color Macro 41	161-164	224	5	97	0
Color Macro 9	33-36	255	166	77	77	Color Macro 42	165-168	175	77	173	0
Color Macro 10	37-40	255	125	74	74	Color Macro 43	169-172	119	130	199	0
Color Macro 11	41-44	255	97	77	71	Color Macro 44	173-176	147	164	212	0
Color Macro 12	45-48	255	74	77	71	Color Macro 45	177-180	88	2	163	0
Color Macro 13	49-52	255	83	134	83	Color Macro 46	181-184	0	38	86	0
Color Macro 14	53-56	255	93	182	93	Color Macro 47	185-188	0	142	208	0
Color Macro 15	57-60	255	96	236	96	Color Macro 48	189-192	52	148	209	0
Color Macro 16	61-64	238	93	255	93	Color Macro 49	193-196	1	134	204	0
Color Macro 17	65-68	163	87	255	87	Color Macro 50	197-200	0	145	212	0
Color Macro 18	69-72	150	90	255	90	Color Macro 51	201-204	0	121	192	0
Color Macro 19	73-76	100	77	255	77	Color Macro 52	205-208	0	129	184	0
Color Macro 20	77-80	77	100	255	77	Color Macro 53	209-212	0	83	115	0
Color Macro 21	81-84	67	148	255	67	Color Macro 54	213-216	0	97	166	0
Color Macro 22	85-88	77	195	255	77	Color Macro 55	217-220	1	100	167	0
Color Macro 23	89-92	77	234	255	77	Color Macro 56	221-224	0	40	86	0
Color Macro 24	93-96	158	255	144	144	Color Macro 57	225-228	209	219	182	0
Color Macro 25	97-100	255	251	153	153	Color Macro 58	229-232	42	165	85	0
Color Macro 26	101-104	255	175	147	147	Color Macro 59	233-236	0	46	35	0
Color Macro 27	105-108	255	138	186	138	Color Macro 60	237-240	8	107	222	0
Color Macro 28	109-112	255	147	251	147	Color Macro 61	241-244	255	0	0	0
Color Macro 29	113-116	151	135	255	138	Color Macro 62	245-248	0	255	0	0
Color Macro 30	117-120	99	0	255	100	Color Macro 63	249-252	0	0	255	0
Color Macro 31	121-124	138	169	255	138	Color Macro 64	253-255	0	0	0	255
Color Macro 32	128-128	255	255	255	255						

TROUBLESHOOTING

Listed below are a few common problems the user may encounter, with solutions.

Unit not powered on:

- Check that the fixture is plugged in.

Unit not responding to DMX:

- Check that the DMX cables are connected properly and are wired correctly (pin 3 is “hot”; on some other DMX devices pin 2 may be ‘hot’). Also, check that all cables are connected to the right connectors; it does matter which way the inputs and outputs are connected.

DISCONNECT POWER BEFORE PERFORMING ANY MAINTENANCE!

CLEANING

Frequent cleaning is recommended to ensure proper function, optimized light output, and an extended life. The frequency of cleaning depends on the environment in which the fixture operates: damp, smoky, or particularly dirty environments can cause greater accumulation of dirt on the fixture’s optics. Clean the external lens surface periodically with a soft cloth to avoid dirt/debris accumulation.

NEVER use alcohol, solvents, or ammonia-based cleaners.

MAINTENANCE

Regular inspections are recommended to ensure proper function and extended life.

There are no user serviceable parts inside this fixture, please refer all other service issues to an authorized ADJ service technician. Should you need any spare parts, please order genuine parts from your local ADJ dealer.

Please refer to the following points during routine inspections:

- A detailed electrical check by an approved electrical engineer every three months, to make sure the circuit contacts are in good condition in order to prevent overheating.
- Be sure all screws and fasteners are securely tightened at all times. Loose screws may fall out during normal operation, resulting in damage or injury as larger parts could fall.
- Check for any deformations on the housing, color lenses, rigging hardware, and rigging points (ceiling, suspension, trussing). Deformations in the housing could allow for dust or liquids to enter into the fixture. Damaged rigging points or unsecured rigging could cause fixture to fall and seriously injure a person(s).
- Electric power supply cables must not show any damage, material fatigue, or sediments.
- **NEVER** remove the ground prong from the power cable.

SPECIFICATIONS

SOURCE

250W RGBWAL (Red/Green/Blue/White/Amber/Lime) LED Engine

50,000 Hour Average LED Life*

*LED Life may vary depending on several factors including but not limited to: Environmental Conditions, Power/Voltage, Usage Patterns (On-Off Cycling), Control, and Dimming.

PHOTOMETRIC DATA

>90CRI 6,000 Total Lumens*

(*with 26° lens)

EFFECTS

Electronic Strobe and Dimming

Variable Dimming Curves and Dimming Modes

Independent dynamic white fader feature that achieves white color temperatures from 2400K to 9000K

GOBOS

Supports "B" Size Metal, HT Transparency Gobos*

GOBO Holder is included

GOBOS are sold separately.

CONTROL / CONNECTIONS

6 DMX Channel Modes (2/4/6/13/14/16)

Adjustable Refresh Rate (900-1500, 25,000 Hz)

4 Button Control Panel

LED Menu Display

Locking 5pin XLR Connector In/Out

Locking Power Connector In/Out

With Wired Digital Communication Network

RDM (Remote Device Management)

SIZE / WEIGHT

Length: 26.9" (688mm) (Lens In)

Width: 11.3" (289mm)

Vertical Height: 17.7" (450mm)

Weight: 20.0 lbs. (9.1 kg)

ELECTRICAL / THERMAL

Quiet Fan Cooling

AC 100-240V - 47/63Hz

250W Max Power Consumption

Power Linking: 3pcs Max @120V / 8pcs Max @240V

14° to 113°F (-10° to 45°C)

APPROVALS / RATINGS

CE I cETLus (Pending) I IP20

INCLUDED ITEMS

(1) Locking Power Cable

Specifications and documentation subject to change without notice.

DIMENSIONS

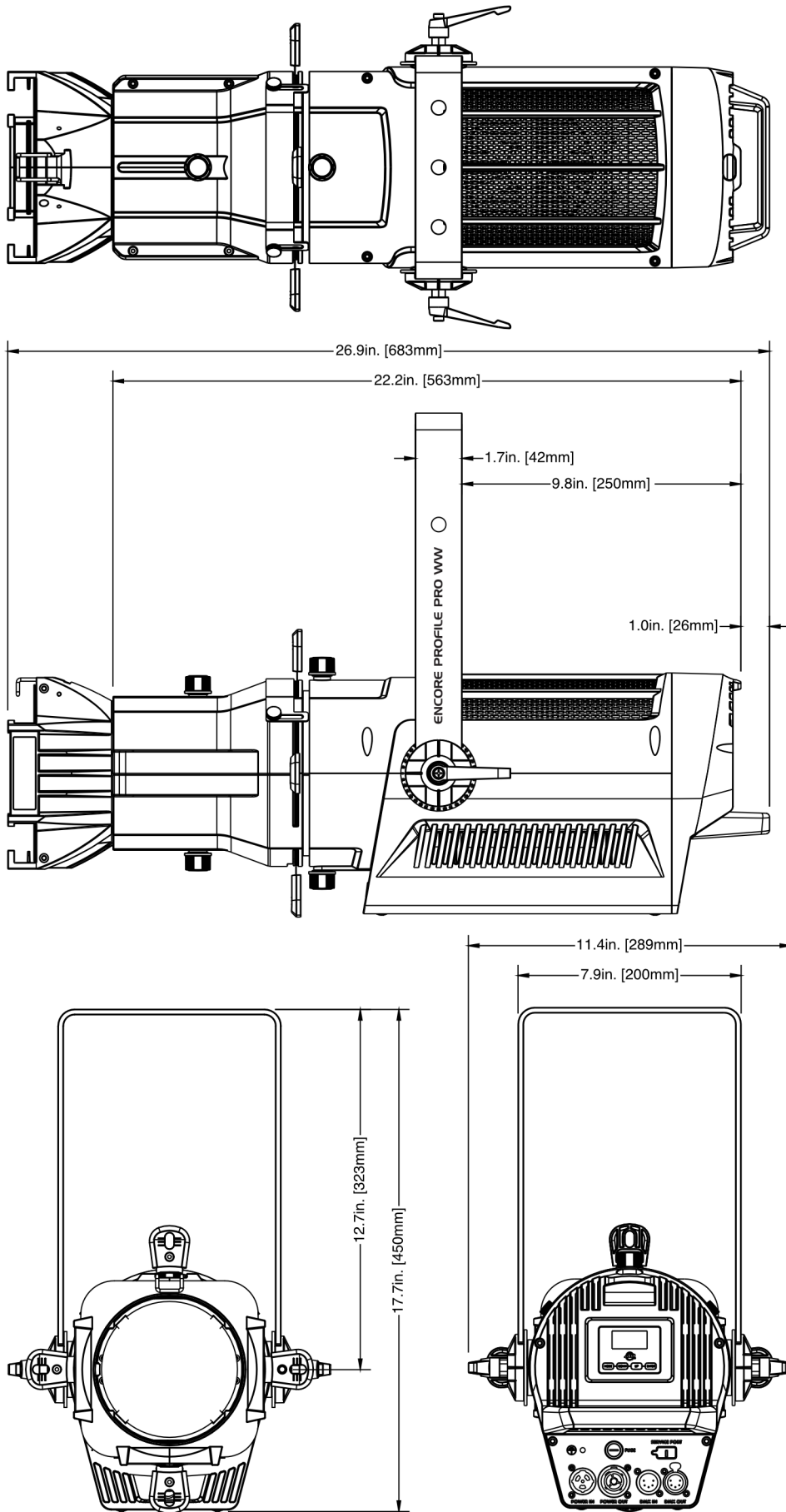

DIMENSIONS: OPTIONAL LENS KIT

Lens Kits are not included

LENS KIT: 5°

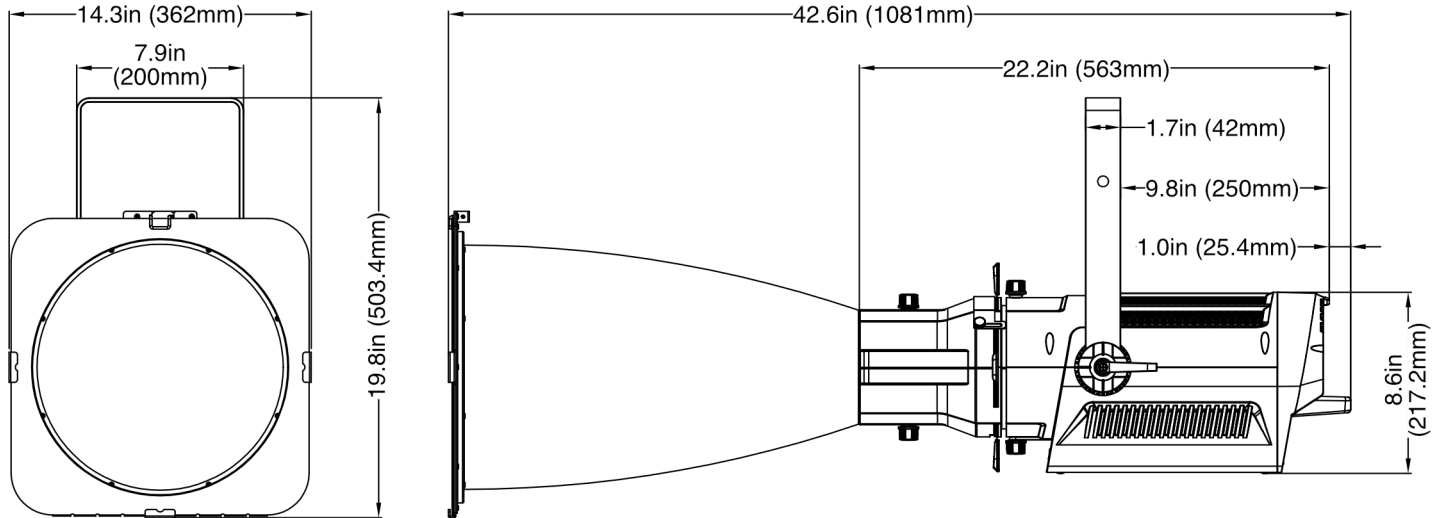

LENS KIT: 10°

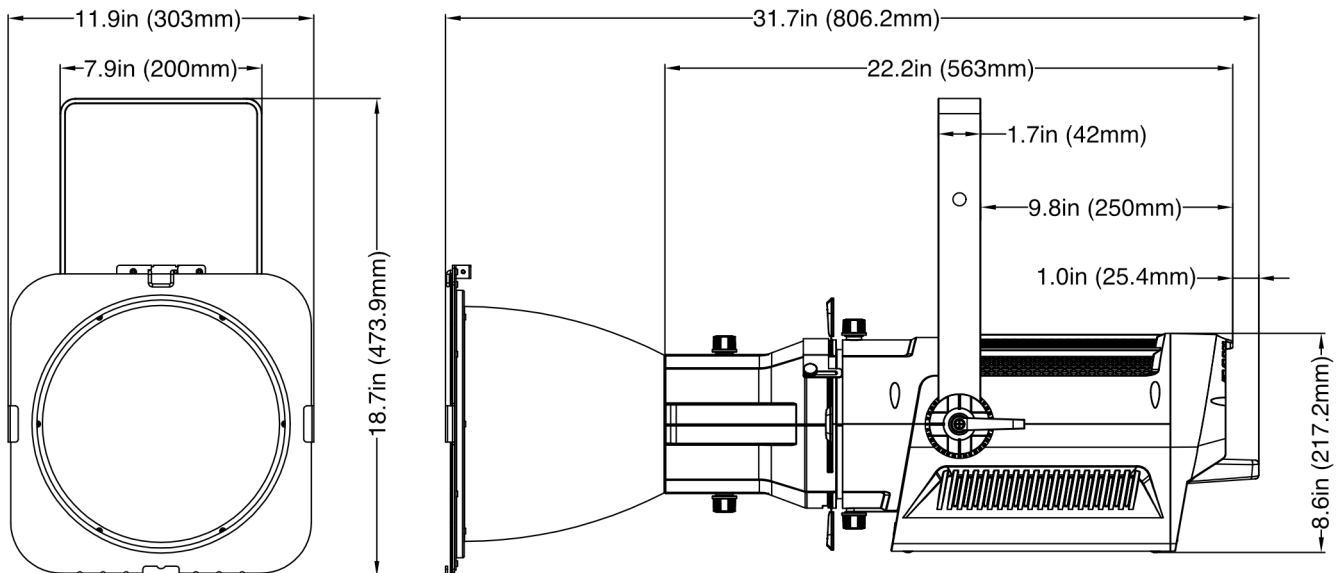

DIMENSIONS: OPTIONAL LENS KIT

Lens Kits are not included

LENS KIT: 14°

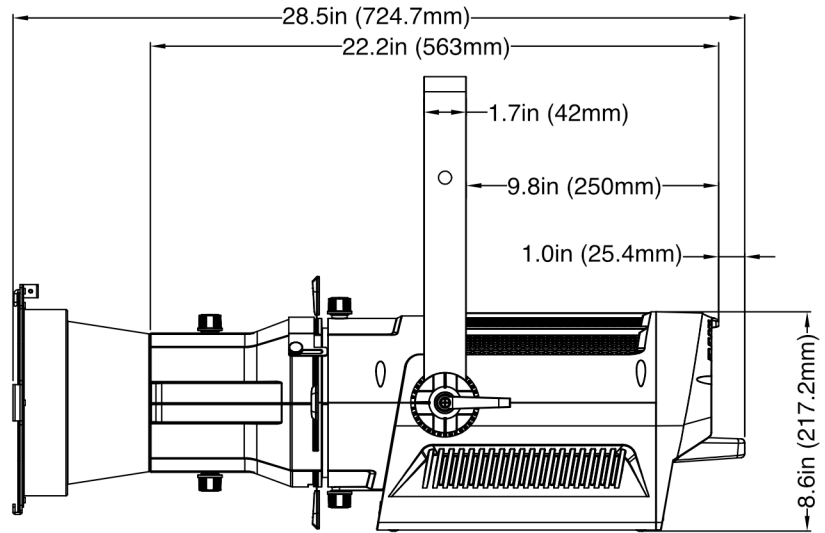
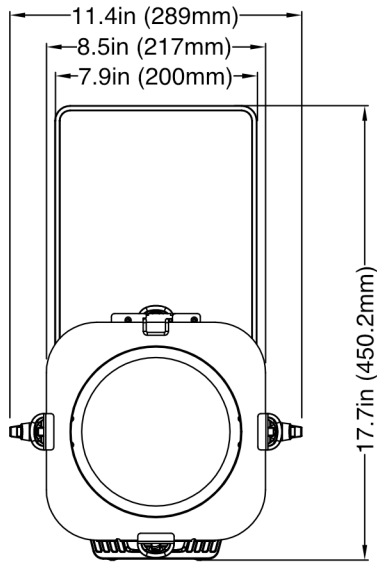

LENS KIT: 19°, 26°, 36°, 50°

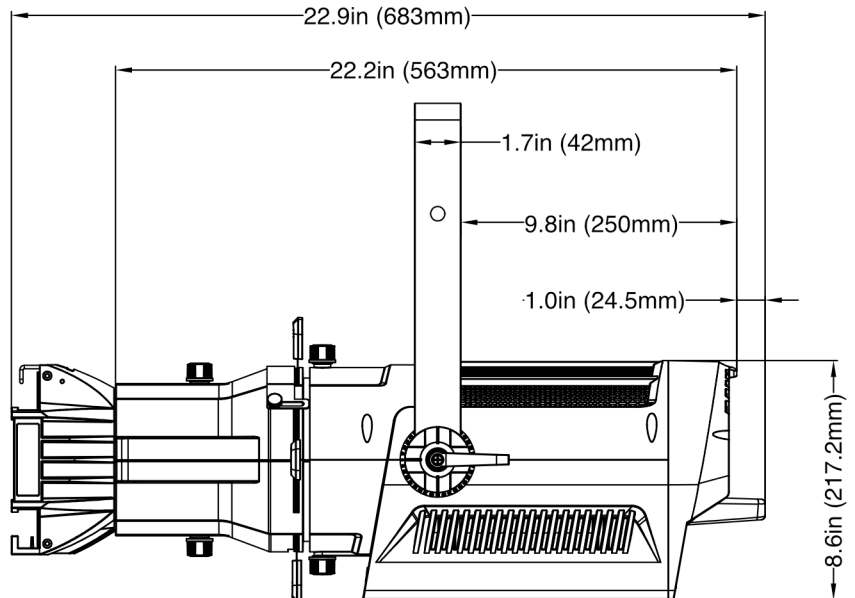
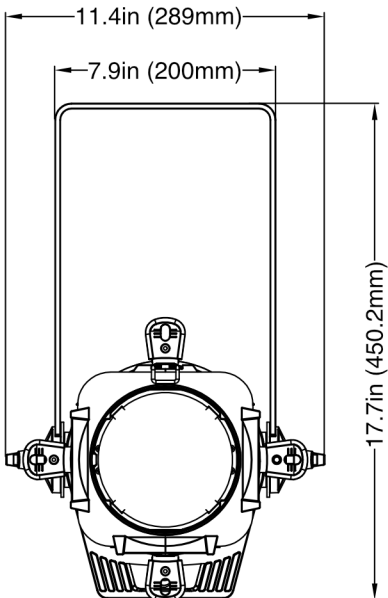

DIMENSIONS: OPTIONAL LENS KIT

Lens Kits are not included

ZOOM LENS KIT: 15° - 30°

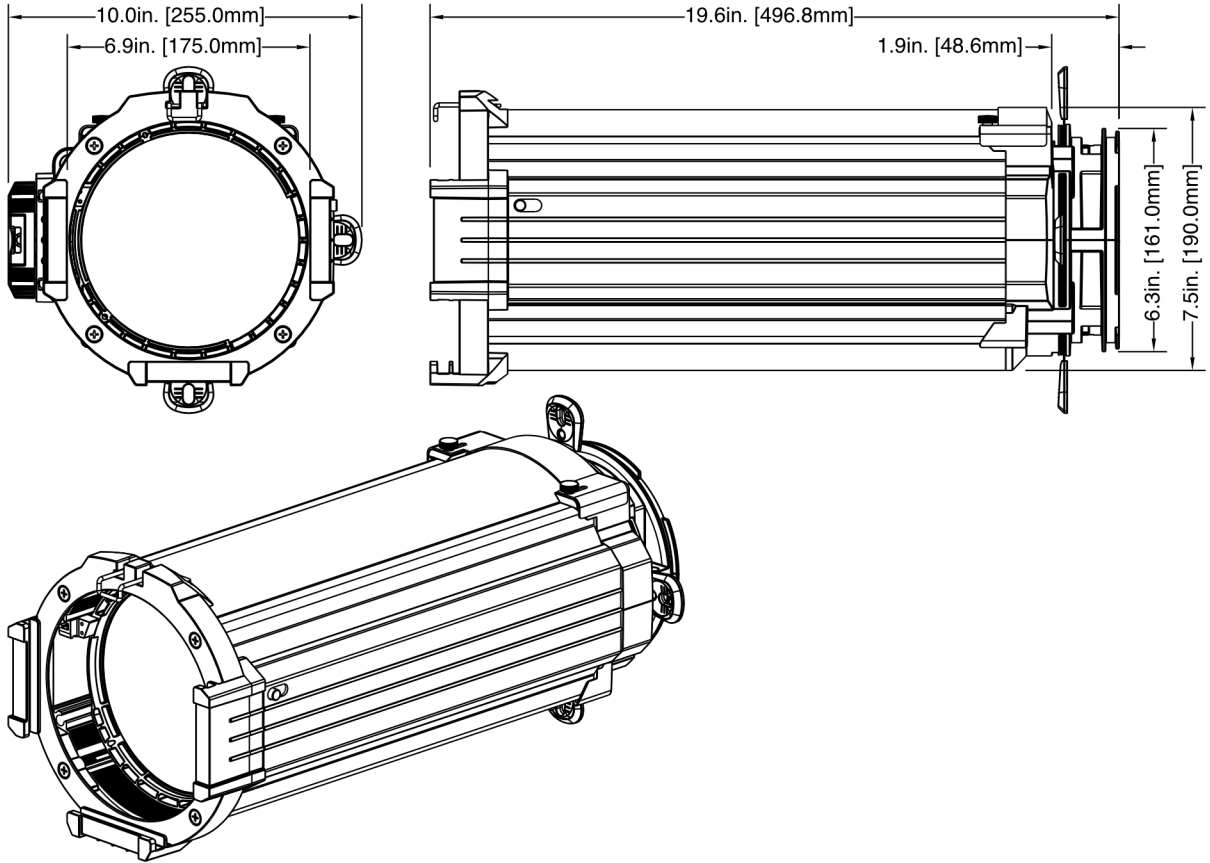

ZOOM LENS KIT: 25° - 50°

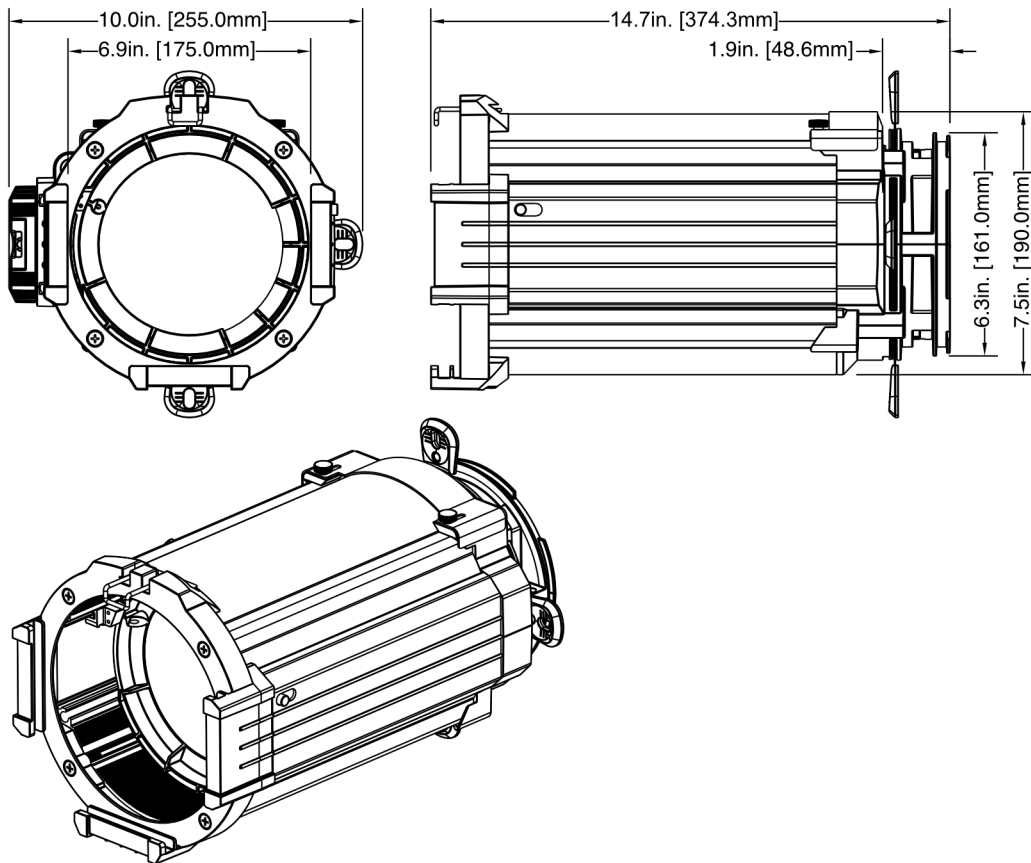

OPTIONAL ACCESSORIES

SKU#	Models
EPP IRIS	EPP001
EPL140	EP Lens 14 (14° Lens).
EPL190	EP Lens 19 (19° Lens)
EPL260	EP Lens 26 (26° Lens)
EPL360	EP Lens 36 (36° Lens)
EPL500	EP Lens 50 (50° Lens)
SIP064	1.64ft. IP65 male to female twist lock power link cable
SIP113	3ft. IP65 male to female twist lock power link cable
SIP126	5ft. IP65 male to female twist lock power link cable
SIP139	10ft. IP65 male to female twist lock power link cable
SIP152	16ft. IP65 male to female twist lock power link cable
SIP165	25ft. IP65 male to female twist lock power link cable
SIP178	50ft. IP65 male to female twist lock power link cable
SIP191	100ft. IP65 male to female twist lock power link cable

FCC STATEMENT

This device complies with Part 15 of the FCC Rules. Operation is subject to the following two conditions: (1) this device may not cause harmful interference, and (2) this device must accept any interference received, including interference that may cause undesired operation.

FCC RADIO FREQUENCY INTERFERENCE WARNINGS & INSTRUCTIONS

This product has been tested and found to comply with the limits as per Part 15 of the FCC Rules. These limits are designed to provide reasonable protection against harmful interference in a residential installation. This device uses and can radiate radio frequency energy and, if not installed and used in accordance with the included instructions, may cause harmful interference to radio communications. However, there is no guarantee that interference will not occur in a particular installation. If this device does cause harmful interference to radio or television reception, which can be determined by turning the device off and on, the user is encouraged to try to correct the interference by one or more of the following methods:

- Reorient or relocate the device.
- Increase the separation between the device and the receiver.
- Connect the device to an electrical outlet on a circuit different from which the radio receiver is connected.
- Consult the dealer or an experienced radio/TV technician for help.

Europe Energy Saving Notice

Energy Saving Matters (EuP 2009/125/EC)

Saving electric energy is a key to help protecting the environment. Please turn off all electrical products when they are not in use. To avoid power consumption in idle mode, disconnect all electrical equipment from power when not in use. Thank you

