

IP TESTER

User Manual

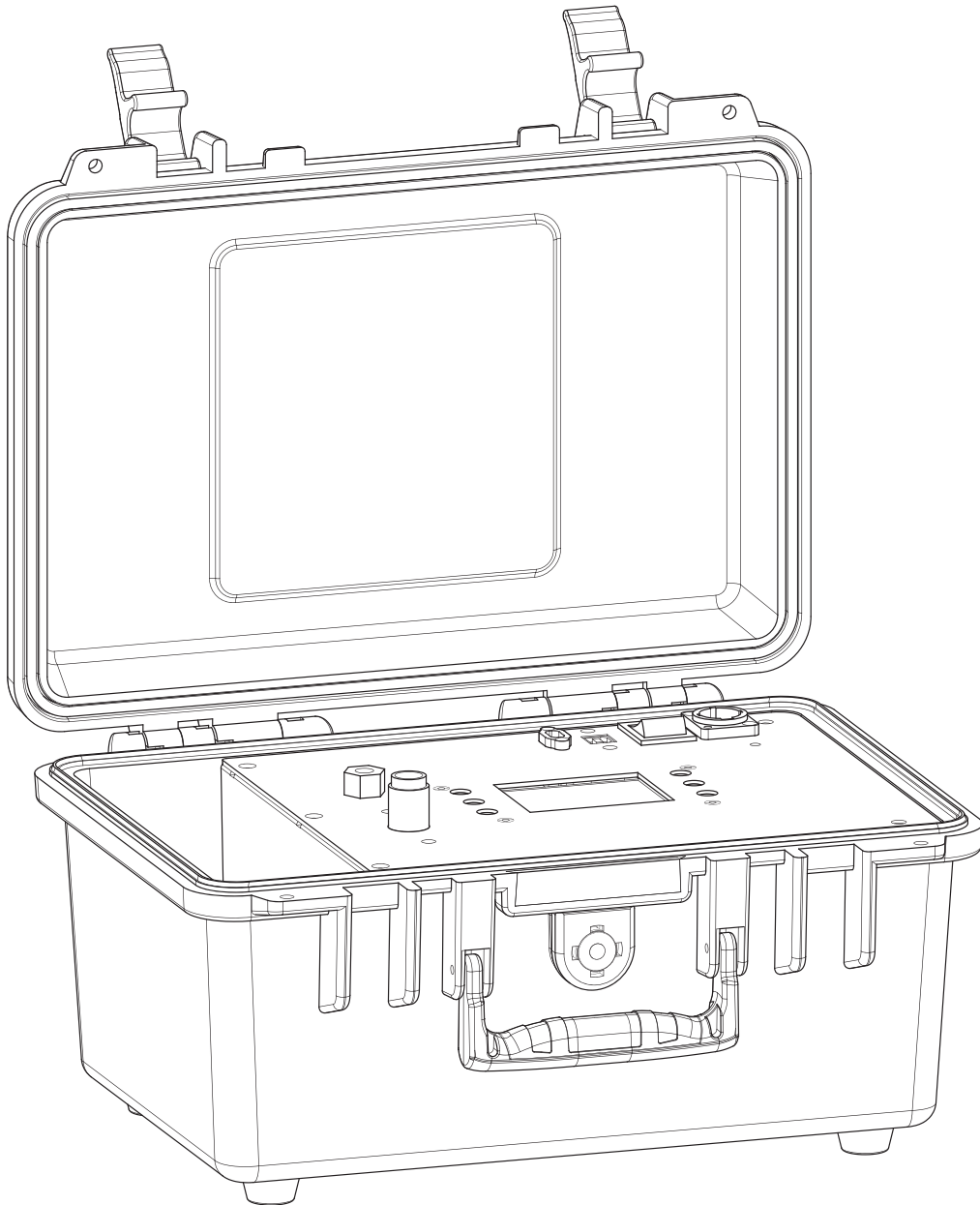

Model ID: IPTESTER

Edition Notes

The IP Tester User Manual includes a description, safety precautions, installation, programming, operation and maintenance instructions for the IP Tester as of the release date of this edition.

Trademarks

Chauvet, Chauvet Professional, and the Chauvet logo are registered trademarks or trademarks of Chauvet & Sons, LLC (d/b/a Chauvet and Chauvet Lighting) in the United States and other countries. Other company and product names and logos referred to herein may be trademarks of their respective companies.

Copyright Notice

The works of authorship contained in this manual, including, but not limited to, all design, text and images are owned by Chauvet.

© **Copyright 2023 Chauvet & Sons, LLC. All rights reserved.**

Electronically published by Chauvet in the United States of America.

Manual Use

Chauvet authorizes its customers to download and print this manual for professional information purposes only. Chauvet expressly prohibits the usage, copy, storage, distribution, modification, or printing of this manual or its content for any other purpose without written consent from Chauvet.

Document Printing

For best results, print this document in color, on letter size paper (8.5 x 11 in), double-sided. If using A4 paper (210 x 297 mm), configure the printer to scale the content accordingly.

Intended Audience

Any person installing, operating, and/or maintaining this product should completely read through the guide that shipped with the product, as well as this manual, before installing, operating, or maintaining this product.

Disclaimer

Chauvet believes that the information contained in this manual is accurate in all respects. However, Chauvet assumes no responsibility and specifically disclaims any and all liability to any party for any loss, damage or disruption caused by any errors or omissions in this document, whether such errors or omissions result from negligence, accident or any other cause. Chauvet reserves the right to revise the content of this document without any obligation to notify any person or company of such revision, however, Chauvet has no obligation to make, and does not commit to make, any such revisions. Download the latest version from www.chauvetprofessional.com.

Document Revision

This IP Tester User Manual is the 1st edition of this document. Go to www.chauvetprofessional.com for the latest version.

TABLE OF CONTENTS

1. Before You Begin 1

 What Is Included 1

 Claims 1

 Text Conventions 1

 Symbols 1

 Safety Notes..... 2

2. Introduction 3

 Description 3

 Features 3

 Product Overview 3

 Product Dimensions 4

3. Setup 5

 AC Power 5

 AC Plug 5

 PC Linking 5

 USB C Storage and Updates 5

 Mounting 5

 Connecting to a Fixture 5

 Storing the Product 5

4. Operation 6

 Control Panel Description 6

 Menu Map 6

 Testing Parameters..... 8

 Configuration (Set-up)..... 8

 Fixture Selection 8

 Unit..... 8

 Edit Fixture Name 8

 Edit Fixture Data 8

 USB Firmware Update 8

 Import Files via USB 9

 Export Files via USB 9

 Delete Fixture 9

 Add New Fixture..... 9

 Information 9

 Testing 10

 Auto Test..... 10

 Manual Test 10

 Self-Test..... 10

 Computer Interface Software 11

5. Maintenance..... 12

 Product Maintenance 12

6. Technical Specifications 13

Contact Us 14

 Warranty & Returns..... 14

1. Before You Begin

What Is Included

- IP Tester
- Neutrik® powerCON® TRUE1 power cable
- USB cable
- 2 condensation valve blanks
- Condensation valve remover tool
- M12 threaded brass nozzle with push-to-connector fitting
- Quick Reference Guide

Claims

Carefully unpack the product immediately and check the container to make sure all the parts are in the package and are in good condition.



If the box or the contents (the product and included accessories) appear damaged from shipping, or show signs of mishandling, notify the carrier immediately, not Chauvet. Failure to report damage to the carrier immediately may invalidate the claim. In addition, keep the box and contents for inspection.

For other issues, such as missing components or parts, damage not related to shipping, or concealed damage, file a claim with Chauvet within 7 days of delivery.

Text Conventions

Convention	Meaning
1–512	A range of values
50/60	A set of values of which only one can be chosen
Settings	A menu option not to be modified
<ENTER>	A key to be pressed on the product’s control panel

Symbols

Symbol	Meaning
	Critical installation, configuration, or operation information. Not following these instructions may make the product not work, cause damage to the product, or cause harm to the operator.
	Important installation or configuration information. The product may not function correctly if this information is not used.
	Useful information.



The term “DMX” used throughout this manual refers to the USITT DMX512-A digital data transmission protocol.

Before You Begin

Safety Notes

Read all the following safety notes before working with this product. These notes contain important information about the installation, usage, and maintenance of this product.



This product contains no user-serviceable parts. Any reference to servicing in this User Manual will only apply to properly trained, certified technicians. Do not open the housing or attempt any repairs.



All applicable local codes and regulations apply to proper installation of this product.

- **CAUTION:**

- This product's housing may be hot when operating. Mount this product in a location with adequate ventilation, at least 20 in (50 cm) from adjacent surfaces.
- When transferring the product from extreme temperature environments, (e.g., cold truck to warm humid ballroom) condensation may form on the internal electronics of the product. To avoid causing a failure, allow the product to fully acclimate to the surrounding environment before connecting it to power.

- **ALWAYS:**

- Disconnect from power before cleaning the product.
- Connect this product to a grounded and protected circuit.

- **DO NOT:**

- Leave any flammable material within 50 cm of this product while operating or connected to power.
- Connect this product to a dimmer or rheostat.
- Operate this product if the housing, lenses, or cables appear damaged.
- Operate this product outdoors or in any location where dust, excessive heat, water, or humidity may affect it. (IP20)
- The maximum ambient temperature is 113 °F (45 °C). Do not operate this product at higher temperatures.
- The minimum startup temperature is -4°F (-20°C). Do not start the product at lower temperatures.
- The minimum ambient temperature is -22°F (-30°C). Do not operate the product at lower temperatures.
- To eliminate unnecessary wear and improve its lifespan, during periods of non-use completely disconnect the product from power via breaker or by unplugging it.
- In the event of a serious operating problem, stop using immediately.



If this Chauvet product requires service, contact Chauvet Technical Support.

2. Introduction

Description

The IP Tester is a portable, compact device for testing the vacuum and pressure capacity of IP-rated products. Testing profiles for Chauvet Professional IP-rated products are pre-loaded, and it is easy to build custom testing profiles. Connect to a PC with the built-in webserver for convenient storage of test data as well as software upgrades.

Features

- Portable, compact IP testing device capable of both vacuum and pressure testing parameters.
- Pre-loaded testing personality files for Chauvet Professional IP-rated products
- Easy to build custom testing profiles
- Built in webserver to easily connect to personal computers for creating fixture profiles and storing information from tests
- USB-C input for easy software upgrades and for storing fixture test data
- USB-B port for easy connection to PC
- Compact and impact resistant ABS plastic case is designed to fit in tool and road cases with touring in mind

Product Overview

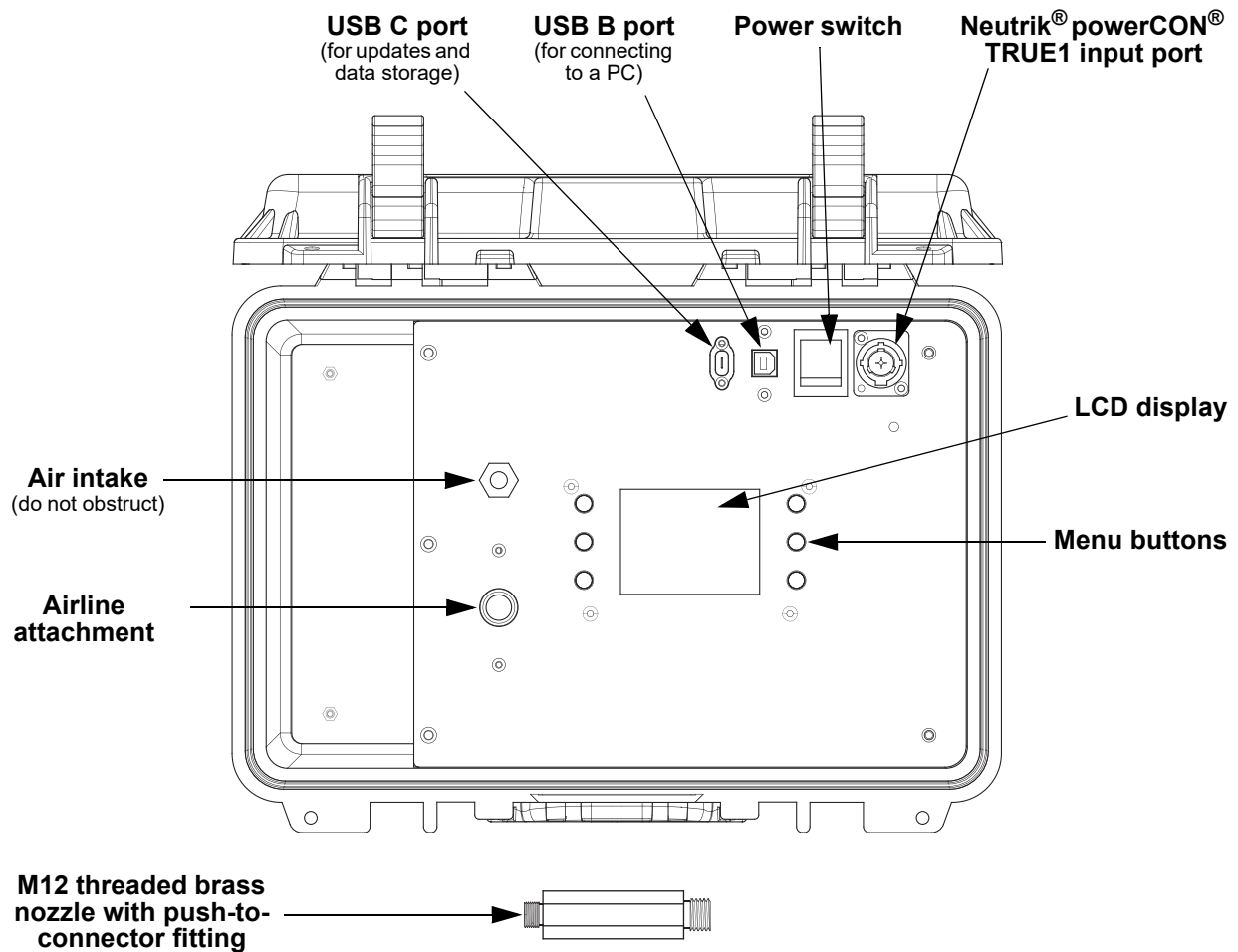

Introduction

Product Dimensions

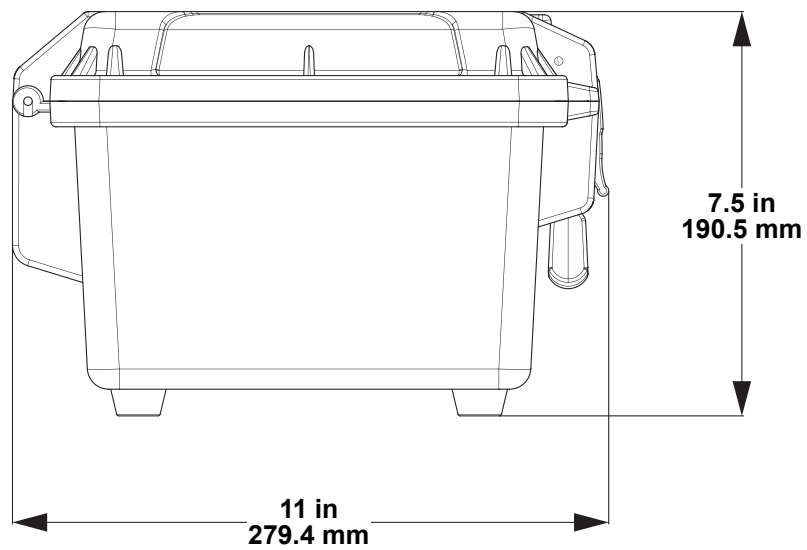
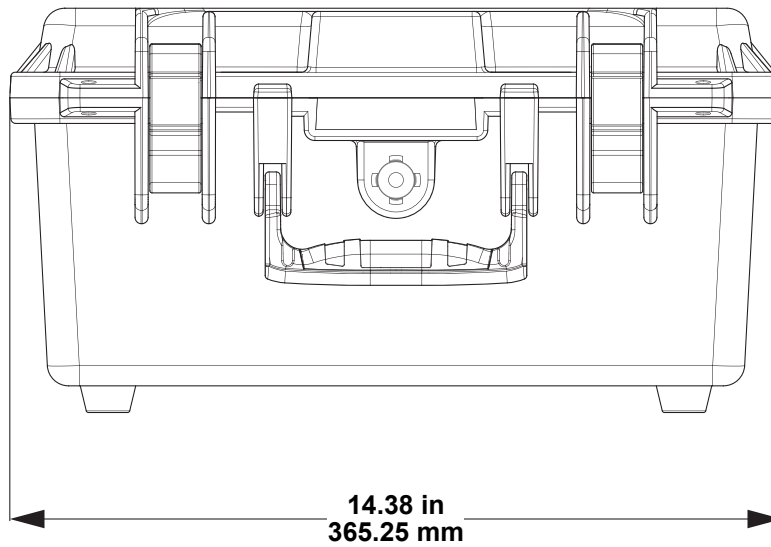

3. Setup

AC Power

The IP Tester has an auto-ranging power supply and it can work with an input voltage range of 100 to 240 VAC, 50/60 Hz.

To determine the product's power requirements (circuit breaker, power outlet, and wiring), use the current value listed on the label affixed to the product's back panel, or refer to the product's specifications chart. The listed current rating indicates the product's average current draw under normal conditions.



- **Always connect the product to a protected circuit (a circuit breaker or fuse). Ensure the product has an appropriate electrical ground to avoid the risk of electrocution or fire.**
- **To eliminate unnecessary wear and improve its lifespan, during periods of non-use completely disconnect the product from power via breaker or by unplugging it.**



Never connect the product to a rheostat (variable resistor) or dimmer circuit, even if the rheostat or dimmer channel serves only as a 0 to 100% switch.

AC Plug

The IP Tester comes with a power input cable terminated with a Seetronic Powerkon A connector on one end and an Edison plug on the other end (U.S. market). If the power cable which came with the product has no plug, or if it is necessary to change the plug, use the table below to wire a plug.

Connection	Wire (U.S.)	Wire (Europe)	Screw Color
AC Live	Black	Brown	Yellow or Brass
AC Neutral	White	Blue	Silver
AC Ground	Green/Yellow	Green/Yellow	Green

PC Linking

The IP Tester is capable of linking with a personal computer using a USB type B to USB type A connection. Easily store and view test data and create fixture profiles via the built-in computer interface software.

USB C Storage and Updates

The IP Tester will work with a USB C drive to perform software updates and store product test data.

Mounting

The IP Tester has a compact and impact-resistant ABS plastic case with rubber feet for placing on a flat and stable surface during use.

Connecting to a Fixture

Follow the instructions below to prepare the IP Tester to perform valid pressure and vacuum tests on a product.

1. Remove all condensation valves on the product with the included condensation valve remover tool and replace all but one of them with the valve blanks. Ensure that all valve blanks are sealed tightly.
2. Attach the threaded end of the M12 threaded brass nozzle to the remaining open condensation valve on the product.
3. Plug the air hose into the airline attachment of the IP Tester.







Storing the Product

When finished testing, the air hose must be removed to allow the case to close correctly.

1. Push down on the outer cylinder of the airline attachment.
2. Pull the air hose out of the attachment.

4. Operation

Control Panel Description

Button	Name	Function
	<UP>	Navigates upwards through the menu list or increases the value when in a function
	<MENU>	Exits from the current menu or function
	<DOWN>	Navigates downwards through the menu list or decreases the value when in a function
	<LEFT>	Navigates leftwards through the menu list
	<ENTER>	Enables the currently displayed menu or sets the selected value into the function
	<RIGHT>	Navigates rightwards through the menu list

Menu Map

Refer to the IP Tester product page on www.chauvetprofessional.com for the latest menu map.

Main Level	Programming Levels				Description
Test	Auto Test	-----	-----	Test again NO YES	Automatic test. See Set-up to select fixture profile. Tests pressure first, and then tests vacuum if pressure passes.
		target value:	_. _ _ psi		
		min value:	_. _ _ psi		
		time hold:	___ s		
		Time hold:	_. _ s		
	Total test time:	_. _ s			
	Manual Test	Vacuum	target value:	-0.00--08.71psi	Sets target value
			min value:	-0.00--08.71psi	Sets minimum value
			time hold:	000--180s	Sets hold time
			start flag:	OFF	Starts/stops manual test
				ON	
			Time hold:	___ s	Shows hold time
		Total test time:	___ s	Shows total test time	
		Pressure	target value:	0.00--08.71psi	Sets target value
			min value:	0.00--08.71psi	Sets minimum value
			time hold:	000--180s	Sets hold time
			start flag:	OFF	Starts/stops manual test
				ON	
			Time hold:	_. _ s	Shows hold time
		Total test time:	_. _ s	Shows total test time	
Self-Test	Vacuum	Max Vacuum value:	-0.00--08.71psi	Sets maximum vacuum value	
		OFF		Activates/deactivates self vacuum test	
	ON				
	Pressure	Max Pressure value:	0.00--08.71psi	Sets maximum pressure value	
		OFF		Activates/deactivates self pressure test	
ON					
Set-up	Fixture select	-----	pressure target value:	_. _ _ psi	Selects this fixture and these settings for auto test. See Edit Fixture > Edit data to set values and hold times.
		-----	time hold:	___ s	
		-----	pressure min value:	_. _ _ psi	

Main Level	Programming Levels				Description	
Fixture select (cont.)	----- (cont.)	vacuum target value:	-.	__psi	Selects this fixture and these settings for auto test. See Edit Fixture > Edit data to set values and hold times.	
		time hold:	---	s		
Fixture select (cont.)	-----	pressure target value:	-.	__psi	Selects this fixture and these settings for auto test. See Edit Fixture > Edit data to set values and hold times.	
		time hold:	---	s		
		pressure min value:	-.	__psi		
		vacuum target value:	-.	__psi		
		time hold:	---	s		
		vacuum min value:	-.	__psi		
Unit	psi				Shows pounds per square inch (0.00–08.71psi)	
	kPa				Shows kilopascals (00.0–60.0kPa)	
Set-up (cont.)	Edit Name	-----	-----	-----	Edits name of fixture	
		-----	-----	-----	Edits name of fixture	
	Edit Fixture	Edit Data	pressure target value:	0.00–	8.71psi	Sets target values, minimum values, and hold times for selected fixture
			time hold:	000–	180s	
			pressure min value:	0.00–	8.71psi	
			vacuum target value:	0.00–	8.71psi	
			time hold:	000–	180s	
			vacuum min value:	0.00–	8.71psi	
			pressure target value:	0.00–	8.71psi	Sets target values, minimum values, and hold times for selected fixture
			time hold:	000–	180s	
			pressure min value:	0.00–	8.71psi	
			vacuum target value:	0.00–	8.71psi	
			time hold:	000–	180s	
			vacuum min value:	0.00–	8.71psi	
USB Update	(0920)	USB Update	NO YES	-----	Updates firmware via USB	
Import File	NO YES				Imports selected file via USB	
Export File	NO YES				Exports files via USB	
Delete Fixture	----- ----- -----	NO YES		-----	Deletes the selected fixture	
Add Fixture	NO				Does not add a fixture	
	YES	Edit Name Edit Data		-----	Adds a fixture “ Example_ ” and prompts to edit	
Information	V_-----				Displays firmware version	

Operation

Testing Parameters

The IP Tester tests the connected product's IP rating integrity using the following parameters:

- **target value:** The IP Tester will create vacuum or pressure of this value before holding. This value is negative for vacuum and positive for pressure.
- **min value:** If the vacuum or pressure goes above (vacuum) or below (pressure) this value while holding, the test fails.
- **time hold:** The IP Tester will hold for this number of seconds after achieving the target value.

Configuration (Set-up)

This section includes instructions for selecting a fixture profile of testing parameters, setting the display unit, editing fixture profiles, using the USB type C port, and deleting or creating fixture profiles.

Fixture Selection

Selecting a fixture profile applies the selected testing parameters to the [Auto Test](#) function.

1. Go to the **Set-up** main level.
2. Select the **Fixture Select** option.
3. Select the desired profile from the list of options. The parameter values will show on the display.

Unit

To select the unit of pressure/vacuum the product will display:

1. Go to the **Set-up** main level.
2. Select the **Unit** option.
3. Set the desired unit from **psi** (pounds per square inch) or **kPa** (kilopascals).

Edit Fixture Name

To edit the name of a fixture profile:

1. Go to the **Set-up** main level.
2. Select the **Edit Fixture** option.
3. Select the **Edit Name** option.
4. Select which profile name to edit from the list of existing profiles.
5. Use **<UP>**, **<DOWN>**, **<LEFT>**, and **<RIGHT>** to set the desired name for the selected profile.

Edit Fixture Data

To set the parameter values of a fixture profile:

1. Go to the **Set-up** main level.
2. Select the **Edit Fixture** option.
3. Select the **Edit Data** option.
4. Select which fixture to edit from the list of existing profiles.
5. Select which parameter to edit, from:
 - **pressure target value:** (from **0.00–08.71psi** or **00.0–60.0kPa**)
 - **time hold:** (for pressure test) (from **000–180s** [seconds])
 - **pressure min value:** (from **0.00–08.71psi** or **00.0–60.0kPa**)
 - **vacuum target value:** (from **0.00–08.71psi** or **00.0–60.0kPa**)
 - **time hold:** (for vacuum test) (from **000–180s** [seconds])
 - **vacuum min value:** (from **0.00–08.71psi** or **00.0–60.0kPa**)
6. Use **<LEFT>** and **<RIGHT>** to set the value of the selected parameter.

USB Firmware Update

To perform a firmware update from a USB drive:

1. Download the latest firmware update file for the IP Tester from www.chauvetprofessional.com and place it on the USB drive.
2. Plug the USB drive into the USB type C port of the IP Tester.
3. Go to the **Set-up** main level.
4. Select the **USB Update** option.
5. Use **<UP>** (increases the number value of the selected digit) and **<DOWN>** (selects the next digit) to enter the passcode (**0920**).
6. Select the **USB Update** option.
7. Select **NO** (cancel) or **YES** (continue).
8. Select the firmware update file from the list of options.

Import Files via USB

To import a file from a USB drive:

1. Plug the USB drive into the USB type C port of the IP Tester.
2. Go to the **Set-up** main level.
3. Select the **Import File** option.
4. Select **NO** (cancel) or **YES** (continue).
5. Select the desired file from the list of options.

Export Files via USB

To export data to a USB drive:

1. Plug the USB drive into the USB type C port of the IP Tester.
2. Go to the **Set-up** main level.
3. Select the **Export File** option.
4. Select **NO** (cancel) or **YES** (exports 2 text files to the USB drive).

Delete Fixture

To delete a fixture profile from the IP Tester:

1. Go to the **Set-up** main level.
2. Select the **Delete Fixture** option.
3. Select the desired fixture profile from the list of options.
4. Select **NO** (cancel) or **YES** (delete selected fixture profile).

Add New Fixture

To add a new fixture profile to the IP Tester:

1. Go to the **Set-up** main level.
2. Select the **Add Fixture** option.
3. Select **NO** (cancel) or **YES** (add a new fixture profile called **Example_**).
4. Select the **Edit Name** option or the **Edit Data** option.
5. Follow step 5 under [Edit Fixture Name](#) and steps 5–6 under [Edit Fixture Data](#).

Information

To view the current firmware version of the IP Tester, go to the **Information** main level.

Testing

The IP Tester can perform automatic tests based on the selected fixture profile, manual pressure or vacuum tests based on easily changeable parameter values, and self-tests to ensure the IP Tester is functioning correctly.

Auto Test

To perform an automatic test on a product with an existing fixture profile on the IP Tester:

1. Follow the instructions under [Connecting to a Fixture](#).
2. Follow the instructions under [Fixture Selection](#).
3. Go to the **Test** main level.
4. Select the **Auto Test** option. The IP Tester will begin testing the connected product. While testing, the **Time hold** will count down and the **Total test time** will count up on the display.
5. When both tests are completed, select **NO** (do not test again) or **YES** (test again).



If either test fails, double-check all hose connections and check that the valve blanks in the condensation valves of the product are sealed tight, as well as the M12 threaded brass nozzle of the IP Tester. If tests continue to fail, contact Chauvet Technical Support.

Manual Test

To perform a manual test on a product without an existing fixture personality on the IP Tester:

1. Follow the instructions under [Connecting to a Fixture](#).
2. Go to the **Test** main level.
3. Select the **Manual Test** option.
4. Select the **Vacuum** option or the **Pressure** option.
5. Use **<LEFT>** and **<RIGHT>** to set the **target value**, **min value**, and **time hold** to the values required for the connected product.
6. To start the test, select **start flag** and press **<LEFT>** or **<RIGHT>** to set it to **ON**.



If either test fails, double-check all hose connections and check that the valve blanks in the condensation valves of the product are sealed tight, as well as the M12 threaded brass nozzle of the IP Tester. If tests continue to fail, contact Chauvet Technical Support.

Self-Test

To perform a self-test on the IP Tester and verify the pressure and vacuum capacity of the product:

1. Attach the air hose to the airline attachment of the IP Tester.
2. Go to the **Test** main level.
3. Select the **Self-Test** option.
4. Select the **Vacuum** option or the **Pressure** option.
5. Use **<LEFT>** and **<RIGHT>** to set the **Max Vacuum value** or the **Max Pressure value**.
6. Block the end of the M12 threaded brass nozzle completely with a finger or thumb.
7. To start the test, select **OFF** and press **<RIGHT>** to set it to **ON**.



If either test fails, contact Chauvet Technical Support.

Computer Interface Software

To access recorded data via a linked PC:

1. Download the computer interface software from www.chauvetprofessional.com.
2. Connect the IP Tester to power.
3. Connect the IP Tester to the PC via the UBS type B port with the included USB cable.
4. Open the computer interface software.
5. Click **Connect**.

IP Tester 1.0

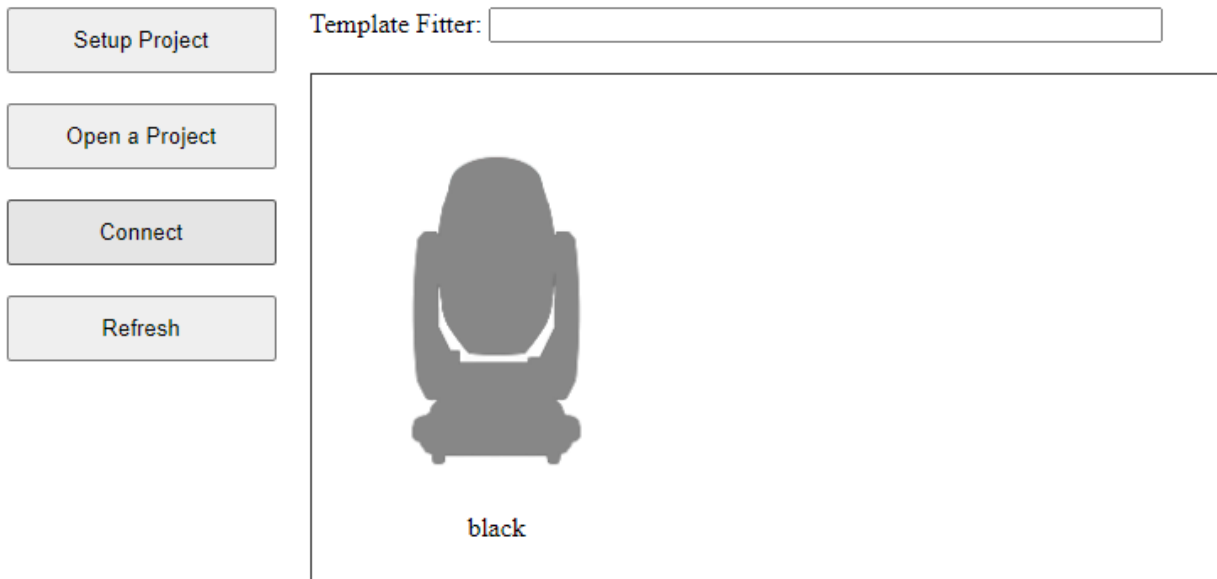

6. Select the COM port to which the IP Tester is connected.
7. The IP Tester will upload data automatically and allow setup and control.

5. Maintenance

Product Maintenance

Dust build-up reduces performance and can cause overheating. This can lead to reduction of the product lifespan and/or mechanical wear. To maintain optimum performance and minimize wear, clean all lighting products at least twice a month. However, be aware that usage and environmental conditions could be contributing factors to increase the cleaning frequency.

To clean the product, follow the instructions below:

1. Unplug the product from power.
2. Wait until the product is at room temperature.
3. Use a vacuum (or dry compressed air) and a soft brush to remove dust collected on the external surfaces.
4. Clean with a mild soap solution, ammonia-free glass cleaner, or isopropyl alcohol.
5. Apply the solution directly to a soft, lint free cotton cloth or a lens cleaning tissue.
6. Softly drag any dirt or grime to the edge of the surface.



Always dry the product carefully after cleaning it.

6. Technical Specifications

Dimensions and Weight

Length	Width	Height	Weight
14.38 in (365.25 mm)	11 in (279.4 mm)	7.5 in (190.5 mm)	9 lb (4.1 kg)

Note: Dimensions in inches are rounded.

Power

Power Supply Type	Range	Voltage Selection
Switching (internal)	100 to 240 VAC, 50/60 Hz	Auto-ranging

Parameter	100 V, 60 Hz	120 V, 60 Hz	208 V, 60 Hz	230 V, 50 Hz	240 V, 50 Hz
Consumption	28 W	28 W	28 W	28 W	28 W
Operating Current	0.453 A	0.379 A	0.240 A	0.226 A	0.222 A

Power I/O	U.S./Worldwide	UK/Europe
Power Input Connector	Seetronic Powerkon IP65	Seetronic Powerkon IP65
Power Cable plug	Edison	Local plug

Thermal

Maximum External Temperature	Cooling System
113 °F (45 °C)	Convection

Control

I/O Connector
USB-B, USB-C

Ordering

Product Name	Item Name	Item Code	UPC Number
IP Tester	IPTESTER	25991743	781462220914



Contact Us

General Information	Technical Support
Chauvet World Headquarters	
Address: 3360 Davie Rd. Davie, FL 33314 Voice: (954) 577-4455 Fax: (954) 929-5560 Toll Free: (800) 762-1084	Voice: (844) 393-7575 Fax: (954) 756-8015 Email: chauvetcs@chauvetlighting.com Website: www.chauvetprofessional.com
Chauvet U.K.	
Address: Pod 1 EVO Park Little Oak Drive, Sherwood Park Nottinghamshire, NG15 0EB U.K. Voice: +44 (0) 1773 511115 Fax: +44 (0) 1773 511110	Email: UKtech@chauvetlighting.eu Website: www.chauvetprofessional.eu
Chauvet Benelux	
Address: Stokstraat 18 9770 Kruishoutem Belgium Voice: +32 9 388 93 97	Email: BNLtech@chauvetlighting.eu Website: www.chauvetprofessional.eu
Chauvet France	
Address: 3, Rue Ampère 91380 Chilly-Mazarin France Voice: +33 1 78 85 33 59	Email: FRtech@chauvetlighting.fr Website: www.chauvetprofessional.eu
Chauvet Germany	
Address: Bruno-Bürgel-Str. 11 28759 Bremen Germany Voice: +49 421 62 60 20	Email: DEtech@chauvetlighting.de Website: www.chauvetprofessional.eu
Chauvet Mexico	
Address: Av. de las Partidas 34 - 3B (Entrance by Calle 2) Zona Industrial Lerma Lerma, Edo. de México, CP 52000 Voice: +52 (728) 690-2010	Email: servicio@chauvet.com.mx Website: www.chauvetprofessional.mx

Warranty & Returns

For warranty terms and conditions and return information, please visit our website.

For customers in the United States and Mexico: www.chauvetlighting.com/warranty-registration.

For customers in the United Kingdom, Republic of Ireland, Belgium, the Netherlands, Luxembourg, France, and Germany: www.chauvetlighting.eu/warranty-registration.