

CPI2000 Cinema Processor

User Guide





Please read this manual carefully before using the product for the first time!

Professional Contacts

Contact the JBL Professional Distributor in your area.

A complete list of JBL Professional international distributors is available at www.jblpro.com.

Customer Service

400 166 7806

Monday - Friday

9:00am - 6:00pm

Website

www.jblpro.com

Product Registration

Register your product online at www.jblpro.com/registration.

TABLE OF CONTENTS

| | |
|----------------------------|----|
| SAFETY INSTRUCTIONS | 4 |
| WARRANTY INFORMATION | 6 |
| INTRODUCTION | 7 |
| PANEL OVERVIEW | 8 |
| FRONT PANEL..... | 8 |
| REAR PANEL..... | 13 |
| INSTALLATION..... | 15 |
| MOUNTING | 15 |
| QUICK CONNECTION..... | 16 |
| RESETTING..... | 18 |
| MENU STRUCTURE..... | 19 |
| CONNECTOR PIN-OUT | 20 |
| SPECIFICATIONS | 23 |

SAFETY INSTRUCTIONS

For your own safety and to avoid invalidation of the warranty please read this section carefully.

IMPORTANT SYMBOLS



Caution

Alerts the user to the presence of important operating and maintenance (servicing) instructions in the literature accompanying the appliance.



Warning

Alerts the user to the presence of uninsulated “dangerous voltage” within the product’s enclosure that may be of sufficient magnitude to constitute a risk of electric shock to persons.



Protect your ears

Alerts the user that the product is capability to produce sound which, when monitored through an amplifier or headphones, can damage hearing over time.

SAFETY INSTRUCTIONS

- Read these instructions.
- Keep these instructions.
- Heed all warnings.
- Follow all instructions.
- Clean the apparatus only with a dry cloth.
- Do not install near any heat sources such as radiators, heat resistors, stoves, or other apparatus (including amplifiers) that produce heat.
- Do not block any ventilation openings. Install in accordance with the manufacturer’s instructions.
- Do not use this apparatus near water.
- Do not defeat the safety purpose of the polarized or grounding type plug. A polarized plug has two blades with one wider than the other. A grounding type plug has two blades and a third grounding prong. The wide blade or the third prong are provided for your safety. When the provided plug does not fit into your outlet, consult an electrician for replacement of the obsolete outlet.
- Protect the power cord from being walked on or pinched particularly at plugs, convenience receptacles and the point where they exit from the apparatus.
- Only use attachments/accessories specified by the manufacturer.
- Unplug this apparatus during lightning storms or when unused for long periods of time.
- Refer all servicing to qualified service personnel. Servicing is required when the apparatus has been

damaged in any way such as power-supply cord or plug is damaged, liquid has been spilled or objects have fallen into the apparatus, the apparatus has been exposed to rain or moisture, does not operate normally, or has been dropped.

- Use only with the cart, stand, tripod, bracket, or table specified by the manufacturer, or sold with the apparatus. When the cart is used, use caution when moving the cart/apparatus combination to avoid injury from tip-over.
- No naked flame sources, such as lighted candles or cigarettes etc., should be placed on the apparatus.
- No user serviceable parts. Refer all servicing to a qualified service engineer, through the appropriate JBL dealer.
- The socket-outlet shall be installed near the equipment and shall be easily accessible.



THIS UNIT MUST BE EARTHED. Under no circumstances should the mains earth be disconnected from the mains lead.



All maintenance and service on the product should be carried out by JBL or its authorized agents. JBL cannot accept any liability whatsoever for any loss or damage caused by service, maintenance or repair by unauthorized personnel.



WARNING: To reduce the risk of fire or electric shock, do not expose this apparatus to rain or moisture. Do not expose the apparatus to dripping or splashing and do not place objects filled with liquids, such as vases, on the apparatus. No naked flame sources, such as lighted candles, should be placed on the apparatus.



Ventilation should not be impeded by covering the ventilation openings with items such as newspapers, table cloths, curtains etc.

WARRANTY INFORMATION

The JBL Limited Warranty on CPi2000 is in effect for three years from the date of the first consumer purchase.

Who Is Protected By This Warranty?

Your JBL Warranty protects the original owner and all subsequent owners so long as: A.) Your JBL product has been purchased in China Sales Area (This Warranty does not apply to JBL products purchased elsewhere. Other purchasers should contact the local JBL distributor for warranty information.); and B.) The original dated bill of sale is presented whenever warranty service is required.

What Does The JBL Warranty Cover?

Except as specified below, your JBL Warranty covers all defects in material and workmanship. The following are not covered: Damage caused by accident, misuse, abuse, product modification or neglect; damage occurring during shipment; damage resulting from failure to follow instructions contained in your Instruction Manual; damage resulting from the performance of repairs by someone not authorized by JBL; claims based upon any misrepresentations by the seller; any JBL product on which the serial number has been defaced, modified or removed.

Who Pays For What?

JBL will pay all labor and material expenses for all repairs covered by this warranty. Please be sure to save the original shipping cartons because a charge will be made if replacement cartons are requested. Payment of shipping charges is discussed in the next section of this warranty.

How To Obtain Warranty Performance?

If your JBL product ever needs service, please contact your local JBL distributor or our Customer Service (Hotline: 400 166 7806). You'll need to present the original bill of sale to establish the date of purchase. Please do not ship your JBL product to our Customer Service Center without prior authorization. You are responsible for transporting your product for repair or arranging for its transportation and for payment of any initial shipping charges. However, we will pay the return shipping charges if repairs are covered by the warranty.

Limitation of Implied Warranties

ALL IMPLIED WARRANTIES, INCLUDING WARRANTIES OF MERCHANTABILITY AND FITNESS FOR PARTICULAR PURPOSE, ARE LIMITED IN DURATION TO THE LENGTH OF THIS WARRANTY.

EXCLUSION OF CERTAIN DAMAGES

JBL'S LIABILITY IS LIMITED TO THE REPAIR OR REPLACEMENT, AT OUR OPTION, OF ANY DEFECTIVE PRODUCT AND SHALL NOT INCLUDE INCIDENTAL OR CONSEQUENTIAL DAMAGES OF ANY KIND. SOME STATES DO NOT ALLOW LIMITATIONS ON HOW LONG AN IMPLIED WARRANTY LASTS AND/OR DO NOT ALLOW THE EXCLUSION OF INCIDENTAL OR CONSEQUENTIAL DAMAGES, SO THE ABOVE LIMITATIONS AND EXCLUSIONS MAY NOT APPLY TO YOU. THIS WARRANTY GIVES YOU SPECIFIC LEGAL RIGHTS, AND YOU MAY ALSO HAVE OTHER RIGHTS, WHICH VARY, FROM STATE TO STATE.

INTRODUCTION

CPi2000 is a cinema processor developed by JBL to provide audio enhancement and volume control for digital cinemas. It features D/A convertor, room EQ tuning, volume control and system fault detection and can be configured through a tailor-designed GUI software.

CPi2000 offers four input options – Analog Input, Digital Input, Non-Sync Input and mono Mic Input. The Analog Input and Digital Input accept audio signal from a cinema server. Non-Sync Input receives line level stereo signal from a CD or DVD player for background music playback. Mic Input normally connects to a RTA microphone for room tuning.

CPi2000 installs ten (10) HD-15 Analog Output connectors for passive, bi-amp or tri-amp connection and a 25-pin Analog Output connector for connection with a third party audio system. Its Redundant Output (should work together with Analog Input) connector will bypass the CPi2000 system and directly output audio signals while an operation failure appears.

The large LCD display constantly monitors the status of each channel and provides quick setup of its global output volume. Its specially-designed GUI software helps users set up a cinema audio system in an easy and effortless way.

CPi2000 provides a 1/3 octave GEQ for room tuning via the GUI software and is built-in with a list of variable crossover presets to accept a wide range of cinema speakers.

Designed to use with CROWN cinema amplifiers and JBL cinema speakers, CPi2000 is able to detect faults of amplifiers or speakers and send the fault information to a TMS or a 3rd party control system via its RJ45 connector.

Features

- Support 8 channel digital input.
- Support up to 7.1 channel audio input.
- Designed to use with CROWN cinema amplifiers and JBL cinema loudspeakers.
- Intuitive GUI software for easy set-up and tuning.
- 1/3 octave GEQ, built-in variable crossover presets.
- Backup power supply.
- 2U rack space occupation.
- Large LCD display for channel volume and status monitoring.
- 10 output channels suitable for passive, bi-amp and tri-amp connection.
- 25-pin direct outputs compatible with third party audio system.
- Redundant output (should work together with Analog Input) as countermeasure for emergency operation failure.
- USB port for preset import and export.
- Ethernet port for communication with a TMS or third party control system.

Packing List

- 1 x CPi2000 (this unit)
- 1 x Power Cable (250VAC, 10A)
- 1 x User Guide (this literature)

PANEL OVERVIEW

FRONT PANEL



1. LCD Display

The LCD display is 320x160 pixels. When the unit is powered on, the home screen is displayed, where the hall name, IP address and the global output volume are shown.



Home Screen

The following icons may appear on the display:

- indicates the CPi2000's AC Power Input (1 @ rear panel) is properly connected.
- indicates the CPi2000's Backup DC Power Input (10 @ rear panel) is properly connected.
- indicates the CPi2000's USB Connector (6 @ rear panel) is short-circuited.
- appears if one of the following scenario occurs:
 - The CPi2000 is controlled through the front panel controls, which are left idle for 2 minutes. To unlock the front panel controls, long press the Volume/Edit Encoder (9 @ front panel) for 2 seconds.
 - The CPi2000 is controlled through its GUI software. In this situation, the front panel controls can not be unlocked.



2. Menu Button

By pressing the Menu button, the LCD display (1 @ front panel) will navigate to the menu section. Using the Volume/Edit Encoder (9 @ front panel), the following parameters can be monitored or edited. Please refer to "**MENU STRUCTURE**" for more information.

• INPUT LEVEL

The INPUT LEVEL screen is used to monitor and select an input source. To select one of the following input sources:

- Analog Input (5 @ rear panel) - Press the Analog Input button (3 @ front panel).
- Digital Input (4 @ rear panel) - Press the Digital Input button (5 @ front panel).
- Mic Input (2 @ rear panel) - Press the Mic Input button (4 @ front panel).
- Music (Non-Sync) Input (3 @ rear panel) - Press the Music (Non-Sync) Input button (6 @ front panel).

The selected input source on the INPUT LEVEL screen will be backed in white. For instance,  will turn to  when Mic Input is selected using the Mic Input button.

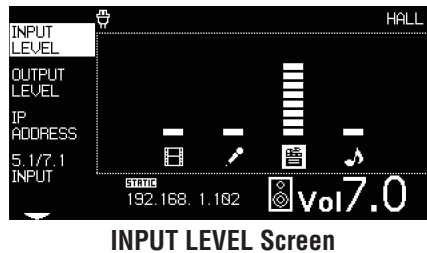

• OUTPUT LEVEL

The OUTPUT LEVEL screen is used to monitor the global output volume of the unit as well as the output volume of each channel. To edit output volume of each channel, please use the GUI software specifically designed for CPi2000.

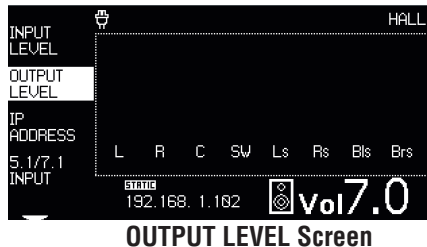

• IP ADDRESS

The IP ADDRESS screen is used to monitor or edit network settings of the unit, which include IP address, Subnet mask, Gateway, etc. The default IP address of CPi2000 is "192.168.1.102", Subnet mask "255.255.255.0", Gateway "192.168.1.101". (NOTE: for MAC address, please refer to the label on the rear panel.)

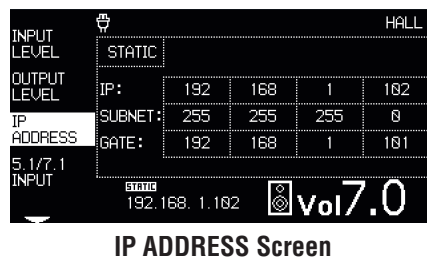

- **5.1/7.1 INPUT**

The 5.1/7.1 INPUT screen is where the input source processing can be selected. The default setting is 5.1 input. Please note, if the unit is set to 5.1 input, BLS and BRS will copy audio signals from LS and RS respectively.



5.1/7.1 INPUT Screen

- **FAULT DETECTION**

The FAULT DETECTION screen shows the fault detected by scrolling the information through the screen.

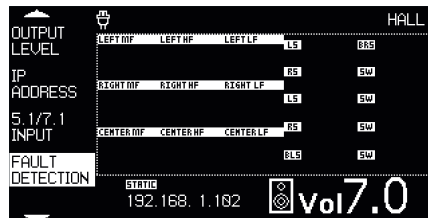

FAULT DETECTION Screen

- **USB**

The USB screen is used to load a preset from or save a preset to a USB device connected to the USB connector (6 @ rear panel). This is helpful when copying the device settings to another CPi2000 or preparing for system upgrading.

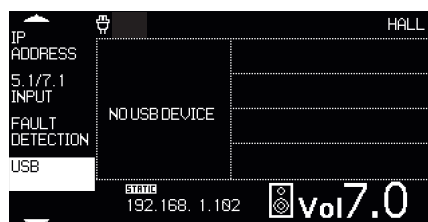

USB Screen

- **RETURN TO PANEL**

RETURN TO PANEL shows the current firmware version of the CPi2000. When the RETURN TO PANEL screen is shown through the LCD display, press the Volume/Edit Encoder (9 @ front panel), then the LCD will navigate back to the home screen.



RETURN TO PANEL Screen

3. Analog Input Button

By pressing the Analog Input Button, input source from the Analog Input Connector (5 @ rear panel) will be used and the button will illuminate to indicate the selection.

4. Mic Input Button

By pressing the Mic Input Button, input source from the Mic Input Connector (2 @ rear panel) will be used and the button will illuminate to indicate the selection.

5. Digital Input Button

By pressing the Digital Input Button, input source from the Digital Input Connector (4 @ rear panel) will be used and the button will illuminate to indicate the selection.

6. Music (Non-Sync) Input Button

By pressing the Music (Non-Sync) Input Button, input source from the Music (Non-Sync) Input (3 @ rear panel) will be used and the button will illuminate to indicate the selection.

7. Power Button

Press the Power button to switch on or off the unit.



NOTE: Ensure the power cable is disconnected from the power supply before installing the unit or doing any service job.



NOTE: Unplug the unit from the power supply during lightning storms or when unused for long periods of time.

8. Mute Button

Press the Mute button to mute or unmute the global output. The button will illuminate when the output is muted.

9. Volume/Edit Encoder

The Volume/Edit Encoder supports long-press, short-press and rotating actions and can be used to unlock front panel

controls, set the global output volume, and navigate through menu screens or edit parameters.

- **To unlock front panel controls (only operatable when the CPi2000 is controlled through front panel controls other than its GUI software)**

1) Long press the Encoder for 2 seconds.



Long press 2 seconds to unlock.

- **To set the global output volume:**

1) Ensure the LCD display is showing the home screen.

2) Rotate the Encoder clockwise to increase the volume or counter-clockwise to decrease the volume.



Rotate clockwise to increase the volume.

- **To navigate through menus or parameters under the Menu button (2 @ front panel):**

1) Press the Menu button (2 @ front panel) to navigate the LCD screen to the Menu section.

2) Rotate the Encoder to select the sub-menu which is going to be checked or edited.

3) Short press the Encoder to navigate to next level menus. Or short press to confirm the any parameter editing.



Rotate to navigate among menus or parameters.

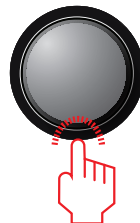

Short press to confirm or navigate to next level menus.

REAR PANEL

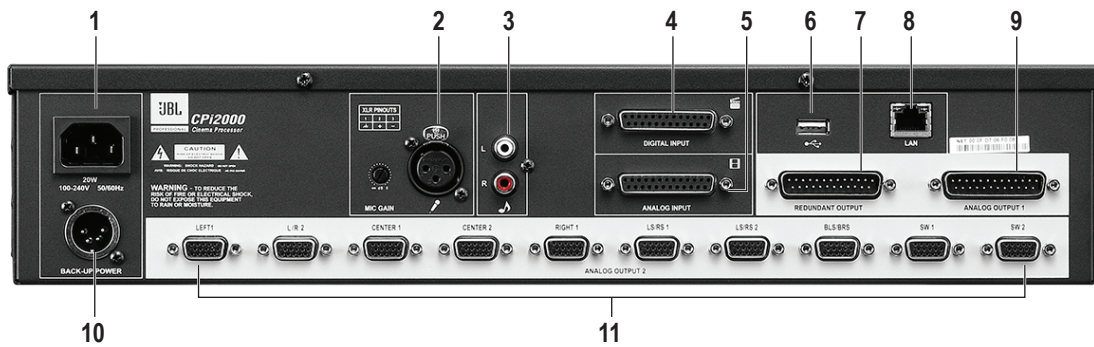

1. AC Power Input

The AC Power Input accepts mains power of 100-240 VAC, 50-60Hz, 20W. Please connect the AC power cable provided by the manufacturer.



NOTE: Ensure the power cable is disconnected from the power supply before installing the unit or doing any service job.



NOTE: Unplug the unit from the power supply during lightning storms or when unused for long periods of time.

2. Mic Input

The Mic Input uses a XLR connector to accept balanced or unbalanced signal with adjustable gain of $-\infty$ dB - 40 dB. +12V phantom power is available and can be switched on or off through the GUI software provided. This connector normally connects to a RTA microphone for room EQ tuning.

By pressing the Mic Input button (4 @ front panel), input signal from the Mic Input will be used.

3. Music (Non-Sync) Input

The Music (Non-Sync) Input uses RCA L-R connectors to accept stereo signal from a CD or DVD player.

By pressing the Music (Non-Sync) Input button (6 @ front panel), input signal from the Music (Non-Sync) Input will be used.

4. Digital Input

The Digital Input uses a female HD-25 connector and normally connects to a cinema server. This input supports up to 7.1-channel audio input and accommodates PCM audio at 96, 48, and 44.1 kHz and 32 kHz (16, 20 and 24 bits) and Dolby Digital at all data rates and sample rates.

5. Analog Input

The 8-channel Analog Input uses a female HD-25 connector and is designed to receive $300\text{mV}_{\text{RMS}}$ (ref) inputs from external sources.

6. USB Connector

This Type-A USB connector can connect to a USB flash disk from preset saving or loading.

7. Redundant Output

This Redundant Output installs a male HD-25 connector which will bypass the CPi2500 system and directly output audio signals in case an operation failure appears to the cinema processor. (**NOTE:** the Redundant Output must work together with Analog Input (5 @ rear panel).)

8. LAN Port

The LAN port uses a RJ45 connector with activity LEDs and provides an interface for TMS (Theatre Management System) communication. This port can also be used for GUI software operation or firmware upgrades.

9. Analog Output 1

The 8-channel Analog Output 1 uses a male HD-25 connector and is compatible with third party audio systems.

10. Backup DC Power Input

This is a 4-pin female XLR connector for use with Cat. No. 994 External Power Supply. This input connects to the +12V 2A DC power adapter (Please consult or purchase from your local dealer or the manufacturer).

11. Analog Output 2

The Analog Output 2 includes ten male HD-15 connectors (Left 1, L/R 2, Center 1, Center 2, Right 1, LS/RS 1, LR/RS 2, BLS/BRS, SW 1, SW 2) and connects to CROWN cinema amplifiers for analog audio output and fault detection signal input. They can be set up through the GUI software.

INSTALLATION

MOUNTING



NOTE: Ensure the power cable is disconnected from the power supply before installing the unit.



NOTE: Please ensure all the rack-mounted devices are properly grounded (earthed).

CPi2000 occupies 2U space and can be placed on a solid and stable surface or mounted on a standard equipment rack. Before mounting or installing the unit, please disconnect its power cable from power supply completely.

To rack-mount the unit, fix its front panel to the rack using the screws provided. See Figure "Rack Mounting".

To avoid hum pickup problems, please locate the unit away from any power amplifiers. For ventilation purpose, always leave 1U space above and below the unit and do not block any ventilation openings.

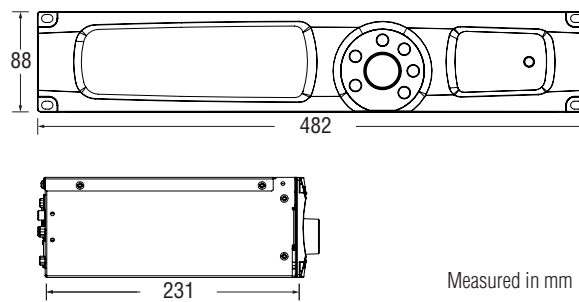

Dimensions

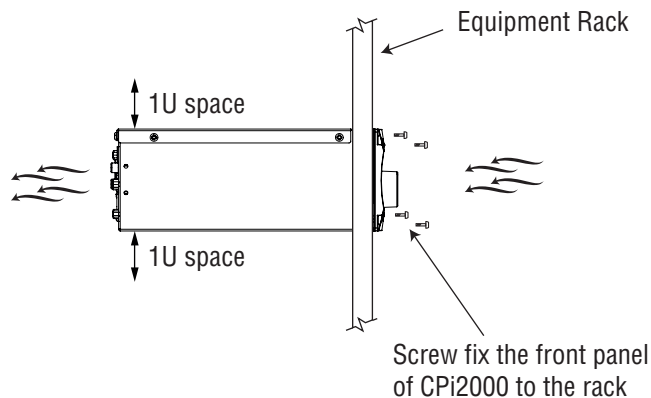

Rack Mounting

QUICK CONNECTION



NOTE: Ensure all the devices are powered off before connection.



NOTE: Turn all the volume controllers of each device to the lowest before connection.



NOTE: Always power on the amplifiers last and power off the amplifiers first.

To start a quick connection of your theatre audio system, please refer to Figure "**Quick Connection Guide**".

1. Connect input devices, e.g. microphone, CD/DVD player, cinema server, control PC, etc.
2. Connect output devices, e.g. power amplifiers and speakers, etc.
3. Connect the unit to power supply.
4. Power on all the devices.

Now you can configure the entire system through the tailor-designed GUI software and monitor the system status via its front panel controls and LCD display.

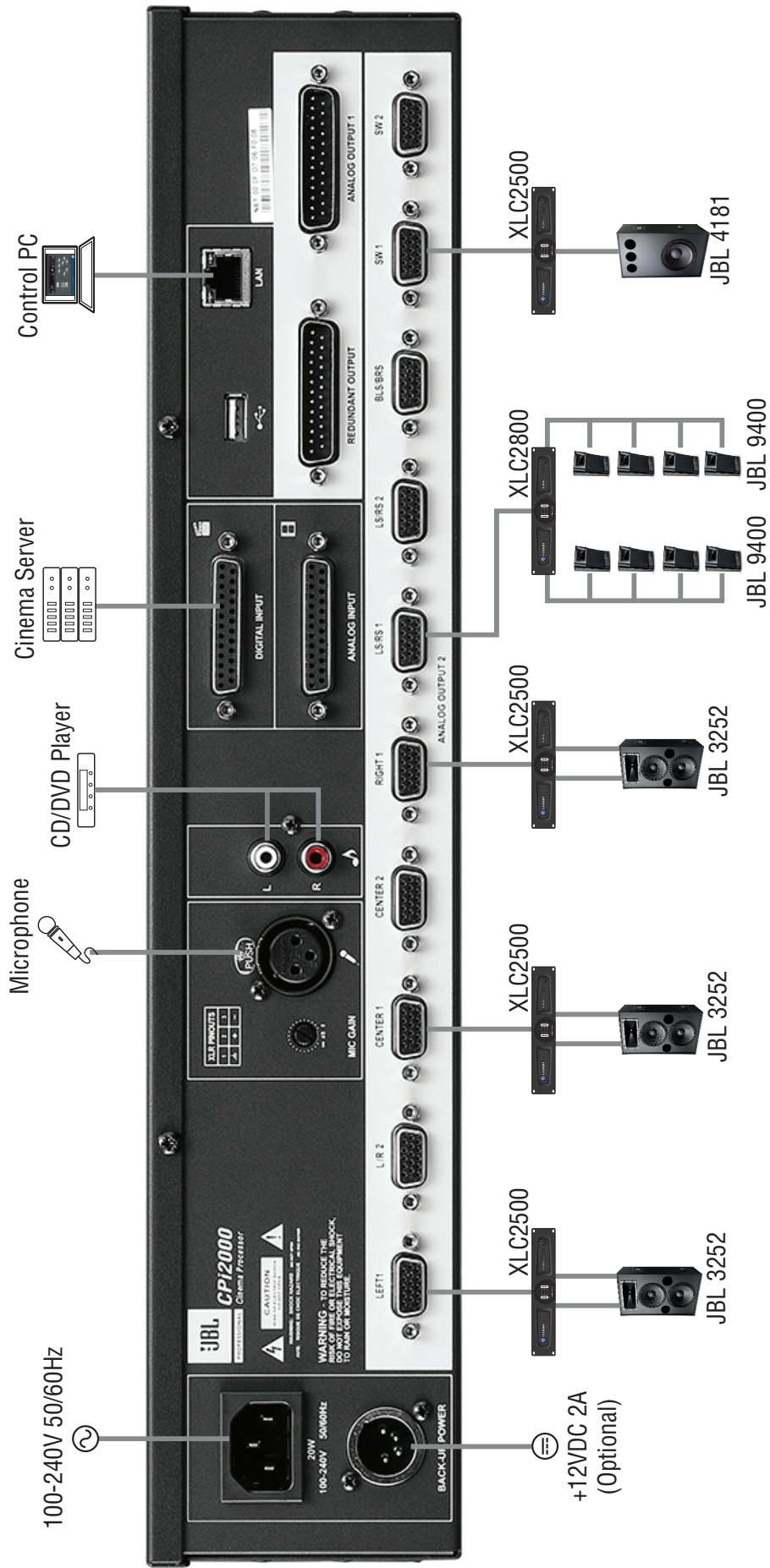

NOTE: Ensure all the devices are powered off before connection.

NOTE: Turn all the volume controllers of each device to the lowest before connection.

NOTE: Always power on the amplifiers last and power off the amplifiers first.

Quick Connection Guide

RESETTING

CPi2000 can be reset using the front panel controls. Such resetting will erase all user data and restore the firmware to factory default. Hence, please save all the device files properly before resetting.

To restore your CPi2000 to factory settings:

1. Press down both the **Mic Input** button (4 @ front panel) and the **Mute** button (8 @ front panel).
2. Switch on the **Power** button (7 @ front panel).
3. Continue to hold the **Mic Input** button and the **Mute** button for about 10 seconds till the LCD shows "RESTORING FACTORY RESETTINGS NOW".



RESTORING FACTORY RESETTINGS NOW

4. Release the two buttons and await about 20 seconds for the CPi2000 to reset and reboot.
5. When the LCD shows the Home Screen, the device is ready for operation.



Home Screen

MENU STRUCTURE

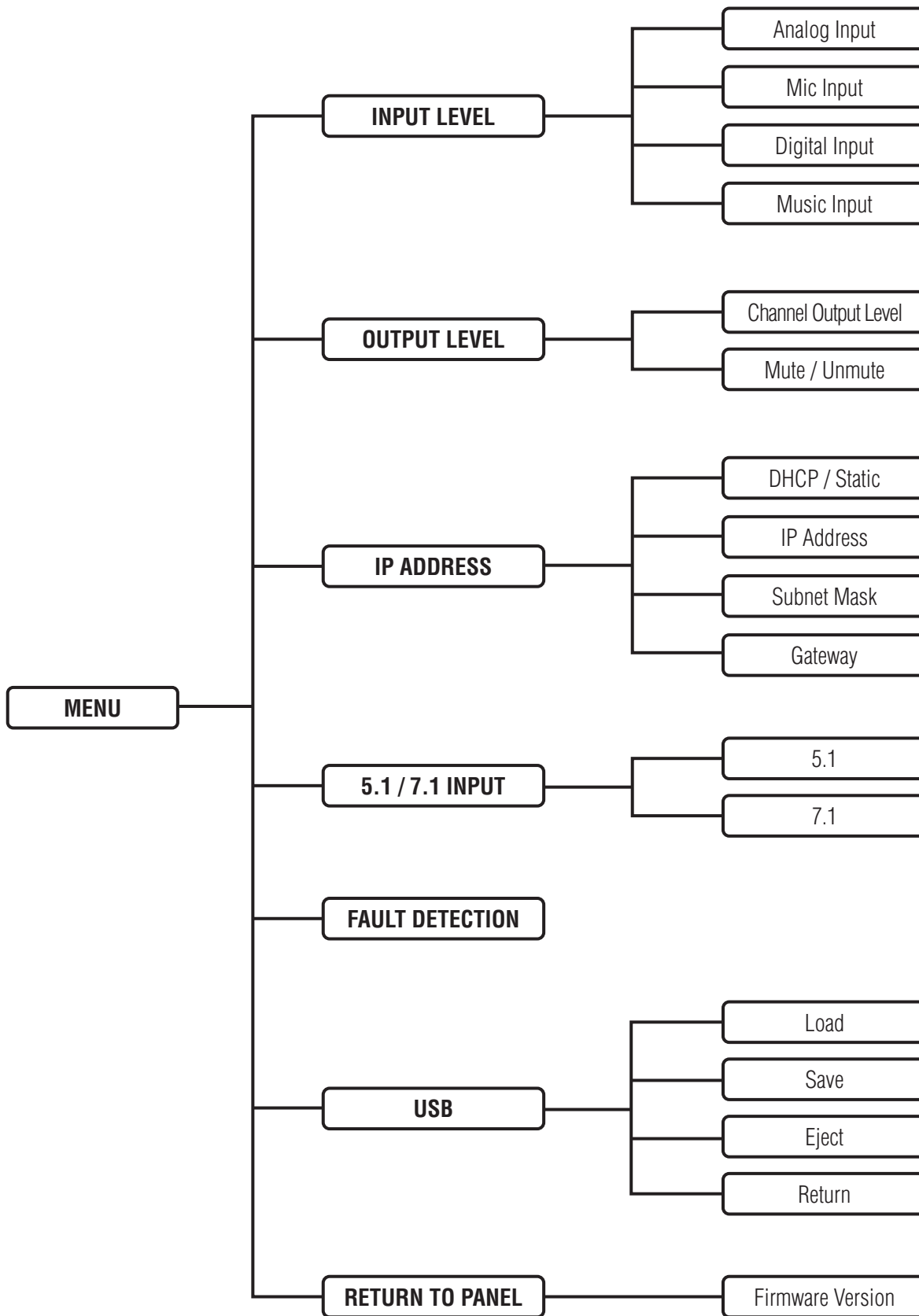

CONNECTOR PIN-OUT

1. Backup DC Power Input Connector

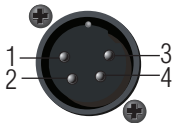
|  | XLR Pin | Connection |
|---|---------|------------|
| | 1 | +12V input |
| | 2 | +12V input |
| | 3 | Ground |
| | 4 | Ground |
| 5 (shell) | Ground | |

2. Mic Input

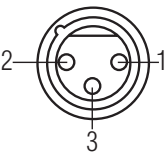
|  <p>(for balanced signal)</p> | XLR Male Plug | Connection | For unbalanced use, connect Pin 1 to 3. |
|--|---------------|-----------------|---|
| | 1 | Ground / Screen | |
| | 2 | Hot (+) | |
| | 3 | Cold (-) | |

3. Digital Input

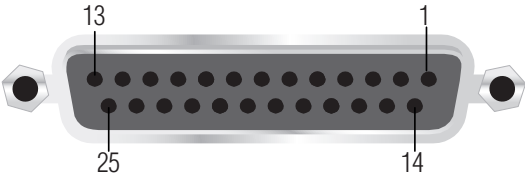
|  <p>(Female)</p> | HD-25 Connector | Connection |
|---|-----------------|---------------|
| | 1 | AES common |
| | 2 | CH 1/2 - |
| | 3 | CH 3/4 + |
| | 4 | AES common |
| | 5 | CH 5/6 - |
| | 6 | CH 7/8 + |
| | 7 | AES common |
| | 8 | No connection |
| | 9 | AES common |
| | 10 | No connection |
| | 11 | No connection |
| | 12 | AES common |
| | 13 | No connection |
| | 14 | CH 1/2 + |
| | 15 | AES common |
| | 16 | CH 3/4 - |
| | 17 | CH 5/6 + |
| | 18 | AES common |
| | 19 | CH 7/8 - |
| | 20 | AES common |
| | 21 | No connection |
| | 22 | No connection |
| | 23 | AES common |
| | 24 | No connection |
| 25 | No connection | |

4. Analog Input / Analog Output 1 / Redundant Output

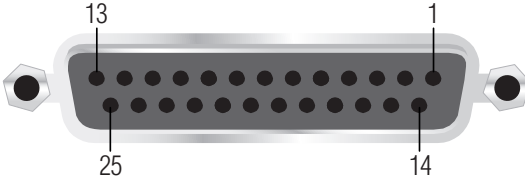
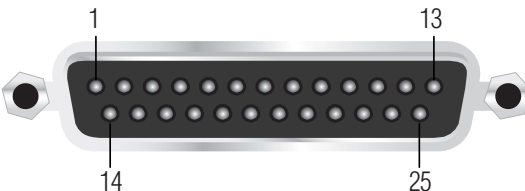
| | HD-25 Connector | Connection |
|--|-----------------|------------|
|  <p>(Analog Input - Female)</p>  <p>(Analog Output 1 & Redundant Output - Male)</p> | 1 | GND |
| | 2 | L + |
| | 3 | BLS - |
| | 4 | GND |
| | 5 | C + |
| | 6 | BRS - |
| | 7 | GND |
| | 8 | R + |
| | 9 | GND |
| | 10 | LS - |
| | 11 | RS - |
| | 12 | SW - |
| | 13 | GND |
| | 14 | L - |
| | 15 | GND |
| | 16 | BLS + |
| | 17 | C - |
| | 18 | GND |
| | 19 | BRS + |
| | 20 | R - |
| | 21 | GND |
| | 22 | GND |
| | 23 | LS + |
| | 24 | RS + |
| | 25 | SW + |

5. Analog Output 2 (10 x HD-15 Connectors)

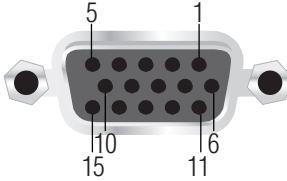
| | HD-15 Connector | Connection |
|---|-----------------|--------------------------|
|  <p>(Female)</p> | 1 | CH 1 Output - |
| | 2 | Null |
| | 3 | Null |
| | 4 | CH 1 Amp Status |
| | 5 | CH 1 Load Current Status |
| | 6 | Null |
| | 7 | CH 1 Output + |
| | 8 | CH 2 Output + |
| | 9 | Null |
| | 10 | GND |
| | 11 | CH 2 Output - |
| | 12 | Null |
| | 13 | Null |
| | 14 | CH 2 Amp Status |
| | 15 | CH 2 Load Current Status |

Channel Assignment of Analog Output 2

| HD-15 Connectors | Tri-Amp | | Bi-Amp | | Passive | |
|------------------|---------|-----------|---------|-----------|---------|--------|
| | Channel | Output | Channel | Output | Channel | Output |
| LEFT 1 | CH1 | Left MF | CH1 | Left LF | CH1 | Left |
| | CH2 | Left HF | CH2 | Left HF | CH2 | Right |
| L/R 2 | CH1 | Left LF | CH1 | Null | CH1 | Null |
| | CH2 | Right LF | CH2 | Null | CH2 | Null |
| CENTER 1 | CH1 | Center MF | CH1 | Center LF | CH1 | Center |
| | CH2 | Center HF | CH2 | Center HF | CH2 | Null |
| CENTER 2 | CH1 | Center LF | CH1 | Null | CH1 | Null |
| | CH2 | Null | CH2 | Null | CH2 | Null |
| RIGHT 1 | CH1 | Right MF | CH1 | Right LF | CH1 | Null |
| | CH2 | Right HF | CH2 | Right HF | CH2 | Null |
| LS / RS 1 | CH1 | LS | CH1 | LS | CH1 | LS |
| | CH2 | RS | CH2 | RS | CH2 | RS |
| LS / RS 2 | CH1 | LS | CH1 | LS | CH1 | LS |
| | CH2 | RS | CH2 | RS | CH2 | RS |
| BLS / BRS | CH1 | BLS | CH1 | BLS | CH1 | BLS |
| | CH2 | BRS | CH2 | BRS | CH2 | BRS |
| SW 1 | CH1 | SW | CH1 | SW | CH1 | SW |
| | CH2 | SW | CH2 | SW | CH2 | SW |
| SW 2 | CH1 | SW | CH1 | SW | CH1 | SW |
| | CH2 | SW | CH2 | SW | CH2 | SW |

SPECIFICATIONS

| INPUT | | |
|------------------------------------|-------------------------|--|
| Digital Input | Connector | Female HD-25 Balanced |
| | Impedance | 110 Ohms |
| | Input level | 0.5 - 10 Vpp |
| Analog Input | Connector | Female HD-25 Balanced or Unbalanced |
| | Impedance | 50K Ohms (Balanced) or 25K Ohms (Unbalanced) |
| | Max. input level | +14.2 dBu |
| Mic Input | Connector | Female XLR Balanced or Unbalanced |
| | Impedance | 660 Ohms (Balanced) or 330 Ohms (Unbalanced) |
| | Total gain | 40 dB |
| | E.I.N. | >113dB, 20K Hz Bandwidth |
| Music (Non-Sync) Input | Connector | RCA |
| | Impedance | 25K Ohms |
| | Max. input level | +14.2 dBu |
| OUTPUT | | |
| Analog Output 1 & Redundant Output | Connector | Male HD-25 Balanced or Unbalanced |
| | Impedance | 30 Ohms (Balanced) or 15 Ohms (Unbalanced) |
| | Max. level | +14.2 dBu |
| | Frequency response | 20 Hz - 20K Hz, Ref 1K Hz +/-1dB |
| | THD + N | <0.01%, 20 Hz - 20K Hz |
| | Dynamic range | >102 dB |
| Analog Output 2 | Connector | 10 x Female HD-15 Balanced or Unbalanced |
| | Impedance | 30 Ohms (Balanced) or 15 Ohms (Unbalanced) |
| | Max. level | +14.2 dBu |
| | Frequency response | 20 Hz - 20K Hz, Ref 1K Hz +/-1dB |
| | THD + N | <0.01%, 20 Hz - 20K Hz |
| | Dynamic range | >102 dB |
| POWER | | |
| AC Power Input | 100-240VAC, 50-60Hz | |
| DC Power Input | +12VDC, 2A | |
| GENERAL | | |
| Rack space | 2U | |
| Dimensions (W x H x D) | 482 mm x 88 mm x 231 mm | |
| Net Weight | 4.0 kg | |
| Shipping Weight | 5.6 kg | |



CPI2000影院处理器

用户手册



首次使用本设备前，请仔细阅读用户手册！

联系方式：

请联系您所在国家或地区的JBL Professional经销商。

有关JBL Professional全球经销商的信息与联系方式，请登录网站：www.jblpro.com。

客户服务热线：

400 166 7806

周一至周五

9:00am - 6:00pm

网址：

www.jblpro.com

产品注册：

在线注册产品，请登录www.jblpro.com/registration。

目录

| | |
|--------------|----|
| 安全须知..... | 4 |
| 质保信息..... | 6 |
| 产品简介..... | 7 |
| 面板概览..... | 8 |
| 前面板 | 8 |
| 后面板 | 13 |
| 安装连接..... | 15 |
| 安装..... | 15 |
| 快速连接..... | 16 |
| 重置..... | 18 |
| 面板菜单结构..... | 19 |
| 连接器引脚定义..... | 20 |
| 规格参数..... | 23 |

安全须知

为确保用户安全与避免保修条款失效，请仔细阅读本章节。

安全标识



注意

用于提醒用户注意产品相关文件中出现的重要操作与维护（维修）说明。



警示

用于提醒用户注意产品中存在无绝缘保护的“危险电压”，防止触电危险。



保护听力

本设备输出的音频信号如长时间通过监听音箱或耳机监听，可能对听力造成损害。

安全须知

- 仔细阅读本用户手册。
- 妥善保管本用户手册。
- 注意所有警示信息。
- 遵守所有操作规范。
- 使用干布清洁本设备。
- 严禁在热源如散热器、热调节器、热炉或其它制热设备（包括功放）等附近安装本设备。
- 严禁堵塞散热口。根据厂商相关说明安装本设备。
- 严禁在近水区域使用本设备。
- 严禁违反极性插头或接地插头的安全使用规范。极性插头由两片宽度不一的金属片构成。接地插头则由两极插片与具有安全保护功能的接地插片构成。如所提供的插头与电源插座不兼容，请更换电源插座。有关电源插座的更换事宜，请咨询电气工程师。
- 保护电源线，避免踩踏或碾压。特别注意保护插头端、插座端与设备端线缆。
- 必须使用厂商指定的附件与配件。
- 雷雨天气或设备长时间停机，请拔下电源插头。
- 如需维护检修，请咨询相关有资质的维修人

员。如有以下情形出现，必须对设备进行检修：电缆或插头损坏、液体渗入、异物掉入、淋雨受潮、无法正常运行或设备摔落等。

- 必须使用厂商指定或随同设备出售的活动机柜、底座、三脚架、支架与作业台。使用活动机柜时，请小心谨慎以防机柜与设备侧翻。
- 严禁在设备上方放置明火，如点燃的蜡烛、香烟等。
- 设备内不含用户可自行维修的元件。如需维护检修，请通过JBL授权经销商咨询相关有资质的维修人员。
- 电源插座应位于设备附近，方便使用。



本设备必须接地！在任何情况下，设备电源必须保持接地良好！



设备的所有检修维护均由JBL或JBL授权代理商实施。因非授权人员维修、维护或修理所造成的任何损失或损坏，JBL不予承担责任。



警告：为避免火灾或触电危险，请勿令本机淋雨受潮。严禁在设备周围喷洒液体。严禁在设备上方摆放盛有液体的容器，如花瓶等。严禁在设备上方放置明火，如点燃的蜡烛、香烟等。



严禁使用报纸、桌布或窗帘等物品遮挡设备的散热口。

产品中有毒有害物质或元素的名称及含量

| 部件名称 | 有毒有害物质或元素 | | | | | |
|----------------|--------------|--------------|--------------|--------------------|------------|--------------|
| | 铅 (Pb) 及其化合物 | 汞 (Hg) 及其化合物 | 镉 (Cd) 及其化合物 | 六价铬 (Cr(VI)) 及其化合物 | 多溴联苯 (PBB) | 多溴二苯醚 (PBDE) |
| 印制电路板 | ○ | ○ | ○ | ○ | ○ | ○ |
| 线材 | ○ | ○ | ○ | ○ | ○ | ○ |
| 除印制电路板外的其他电子组件 | ○ | ○ | ○ | ○ | ○ | ○ |
| 金属件 | X | ○ | ○ | ○ | ○ | ○ |
| 包装材料 | ○ | ○ | ○ | ○ | ○ | ○ |

○：表示该有毒有害物质在该部件所有均质材料中的含量均在SJT 11363-2014规定的限量要求以下。

X：表示该有毒有害物质至少在该部件的某一均质材料中的含量超出SJT 11363-2014规定的限量要求。

根据中国电子行业标准SJT11364-2014和相关的中国政府法规，本产品及其某些内部或外部组件上可能带有环保使用期限标识。取决于组件和组件制造商。产品及其组件上的使用期限标识可能有所不同。组件上的使用期限标识优先于产品上任何与之相冲突的或不同的环保使用期限标识。

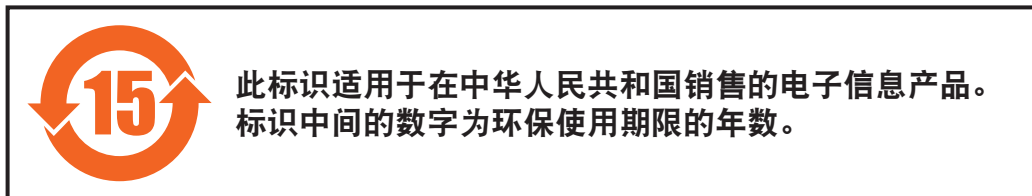

质保信息

自用户首次购买之日起，JBL对CPi2000提供3年有限质保，质保年限见随箱包装质保卡。

哪些人可以享受质保服务？

JBL产品的初始购买者以及相关所有人如需享受JBL质保服务，应满足以下两项条件：A.) 您的JBL产品是在中国地区购买。（本质保不适用于在其他地区购买的JBL产品。在其他地区购买JBL产品的用户，请联系当地JBL经销商了解质保相关信息。）；B.) 享受质保服务前，必须出示标有购买日期的购买单据原件。

JBL质保覆盖范围

JBL质保服务覆盖所有材料与工艺缺陷，但不包含以下情况：因事故、误用、滥用、擅自修改产品或疏忽而造成的损坏；运送过程中造成的损坏；未遵守指引手册规定而造成的损坏；由非JBL授权人员维修而造成的损坏；基于销售方失实陈述而提出的索赔；以及存在序列号污损、被修改或擦除等情况的JBL产品。

费用承担

质保范围内因维修所产生的所有人工与材料费用均由JBL承担。请妥善保管产品的原始包装，否则，因更换包装而产生的费用将由购买者承担。有关运费问题，请参阅下一节内容。

如何获得质保服务

如果您所购买的JBL产品需要质保服务，请联系您所购买产品的经销商或哈曼授权服务中心（热线电话：400 166 7806）。获取JBL质保服务前，您必须出示购买单据原件，以便确定产品购买日期。未获得JBL明确许可，请勿将您的JBL产品送返哈曼授权服务中心。您需要承担产品送返哈曼授权服务中心的运输费用。如产品维修属于质保覆盖范围，我们将承担产品的回程运费。

默示担保

所有默示担保，包括商销性担保与适合特定用途的默示担保，其有效期仅限于本有限质保的有效期内。

免责担保

JBL有限质保范围内的维修或更换（由我方决定）仅限于任何存在缺陷的产品本身，不包含任何附带或间接损坏。部分国家不允许限制默示担保有效期，并且/或者不允许出现免责担保条款，因此，上述默示担保或免责担保可能不适用于您的产品。本有限质保书授予您指定的法律权利，您也可能享有其它权利，具体视所在国家而定。

产品简介

CPi2000 影院处理器由 JBL 研发生产，主要用于数字影院的音效提升与音量控制。CPi2000 搭载高性能数模转换器，提供均衡设置、音量控制与系统故障检测等功能，并配有专门设计的图形用户界面软件。

CPi2000 提供四种输入接口—模拟输入、数字输入、非同步输入与单声道话筒输入。模拟输入与数字输入用于连接影院影音服务器以输入音频信号。非同步输入可连接 CD 或 DVD 播放器，接入线性立体声信号，用于背景音乐播放。话筒输入常用于连接 RTA 话筒，用于辅助房间均衡设置。

CPi2000 设有 10 个 HD-15 模拟输出接口，支持被动、双线分音、三线分音音频连接。25- 针式模拟输出接口可用于连接第三方音频系统。如设备出现运行故障，冗余输出接口（需与模拟输入接口同时使用）将旁通 CPi2000 系统，直接输出音频信号。

前面板 LCD 显示屏持续监控各通道的运行状况，并可快速设置系统全局输出音量。简易直观的专用图形用户界面软件将帮助用户快速搭建影院音频系统。

CPi2000 提供 1/3 倍频程图示均衡器，通过图形用户界面可对音频系统进行精准设置。内置多个分频预置，支持各类影院扬声器连接。

CPi2000 可搭配 CROWN 影院功放与 JBL 影院扬声器使用，可自动检测下游故障，并通过 RJ45 端口将故障信息发送至 TMS 或第三方控制系统。

特点

- 支持 8 路数字输入。
- 支持最高 7.1 声道音频输入。
- 可搭配 CROWN 影院功放与 JBL 影院扬声器使用。
- 简易直观的图形用户界面，用于快速搭建与设置影院音频系统。
- 提供 1/3 倍频程图示均衡器，内置多个分频预置。
- 设有备用电源接口。
- 轻型紧凑机身，仅 2U 机架空间。
- LCD 显示屏用于通道音量与状态监控。
- 10 路输出通道，支持被动、双线分音与三线分音连接。
- 25- 针式输出接口，支持第三方音频系统连接。
- 冗余输出（需与模拟输入接口同时使用）接口可有效应对设备运行故障。
- USB 端口用于预设文件导入导出。
- 网络端口用于设备与 TMS 系统或第三方控制系统间通讯。

包装清单

- 1 x CPi2000（本设备）
- 1 x 电源线（250VAC，10A）
- 1 x 用户手册（本文件）

面板概览

前面板



1. LCD 显示屏

该 LCD 显示屏具有 320x160 像素分辨率。设备开机后，LCD 显示屏将弹出主页面，显示放映厅名称、IP 地址与全局输出音量。



主页面

LCD 显示屏可能出现以下图标：

- 表示 CPi2000 的交流电源输入端口（1 @ 后面板）连接正常。
- 表示 CPi2000 的备用直流电源输入端口（10 @ 后面板）连接正常。
- 表示 CPi2000 的 USB 端口（6 @ 后面板）出现短路。
- 可能在以下情况出现：
 - CPi2000 正通过前面板控制，且前面板控件已闲置 2 分钟。如需解锁，请长按音量 / 编辑旋钮（9 @ 前面板）2 秒。
 - CPi2000 正通过专为用户界面软件控制。此时，前面板控件将无法解锁。

2. 菜单按键【MENU】

轻按菜单按键，LCD 显示屏（1 @ 前面板）将导航至菜单页面。使用音量 / 编辑旋钮（9 @ 前面板），可查看或编辑以下各项设备参数。设备菜单结构的详细设置请参考“**菜单结构**”章节。

• 输入音量【INPUT LEVEL】

输入音量页面用于监控或选择输入音源。如需选择以下音源输入信号：

- 模拟输入（5 @ 后面板）- 轻按模拟输入按键（3 @ 前面板）。

- 数字输入 (4 @ 后面板) - 轻按数字输入按键 (5 @ 前面板)。
- 话筒输入 (2 @ 后面板) - 轻按话筒输入按键 (4 @ 前面板)。
- 音乐 (非同步) 输入 (3 @ 后面板) - 轻按音乐 (非同步) 输入按键 (6 @ 前面板)。

输入音量页面将以白色背景显示被选输入音源。例如，轻按话筒输入按键选中话筒音源，页面中的 将转为 。

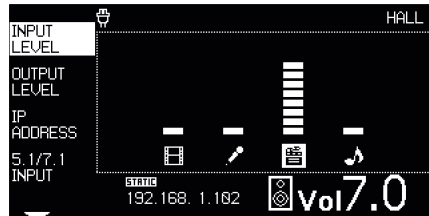

输入音量页面

• 输出音量 [OUTPUT LEVEL]

输出音量页面用于监控设备的全局输出音量以及各通道的输出音量。如需编辑各通道的输出音量，应使用 CPi2000 专用户界面软件。



输出音量页面

• IP 地址 [IP ADDRESS]

IP 地址页面用于监控或编辑设备的网络设置参数，如 IP 地址、子网掩码、网关等。CPi2000 的默认 IP 参数设置为：IP 地址“192.168.1.102”、子网掩码“255.255.255.0”、网关“192.168.1.101”。（注意：如需 MAC 地址信息，请查看后面板处标签。）

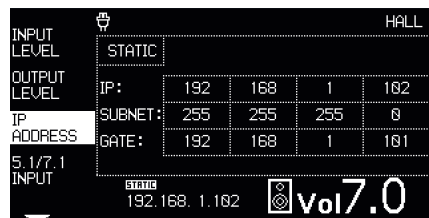

IP地址页面

• 5.1/7.1 输入 [5.1/7.1 INPUT]

5.1/7.1 输入页面用于选择输入音源格式。设备默认为采用 5.1 输入。注意：采用 5.1 输入时，左后环绕 (BLS) 与右后环绕 (BRS) 将分别复制左环绕 (LS) 与右环绕 (RS) 的音频信号。

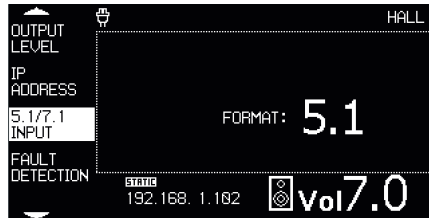

5.1/7.1输入页面

- 故障检测 [FAULT DETECTION]

故障检测页面以滚动方式显示设备检测到的各类故障信息。

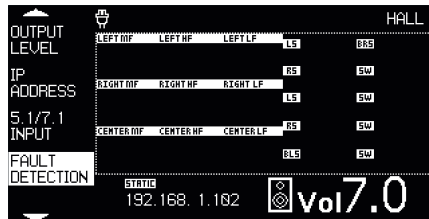

故障检测页面

- USB

USB 页面用于设备预设文件的导入与导出。用于存储预设文件的 USB 驱动盘应连接至设备的 USB 端口 (6 @ 后面板)。USB 文件导入导出可方便用户复制本设备设置至其它 CPI2000 或用于系统升级前的设置文件备份。

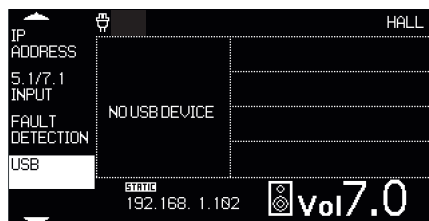

USB页面

- 返回主页 [RETURN TO PANEL]

返回主页页面显示 CPI2000 的当前固件版本信息。LCD 显示屏为返回主页页面时，轻按音量 / 编辑旋钮 (9 @ 前面板)，显示屏将退回至主页面。



返回主页页面

3. 模拟输入按键

轻按模拟输入按键，模拟输入接口（5 @ 后面板）处的输入信号将被选用。此时，该按键将以长亮显示。

4. 话筒输入按键

轻按话筒输入按键，话筒输入接口（2 @ 后面板）处的输入信号将被选用。此时，该按键将以长亮显示。

5. 数字输入按键

轻按数字输入按键，数字输入接口（4 @ 后面板）处的输入信号将被选用。此时，该按键将以长亮显示。

6. 音乐（非同步）输入按键

轻按音乐（非同步）输入按键，音乐（非同步）输入接口（3 @ 后面板）处的输入信号将被选用。此时，该按键将以长亮显示。

7. 电源按键

电源按键用于开启或关闭设备的电源。



注意：安装设备或进行维修操作前，请确保设备电源已完全切断（即设备电源线已与电源插座断开）。



注意：如遇雷雨天气或设备长时间停机，请拔下电源插头。

8. 哑音按键

轻按哑音按键可开启或关闭全局输出音量的哑音设置。哑音设置开启时，该按键将以长亮显示。

9. 音量 / 编辑旋钮

音量 / 编辑旋钮支持长按、短按与旋转操作，可用于解锁前面板控件、调节全局输出音量、菜单页面导航与参数设置编辑等。

- **解锁前面板控件（仅限于 CPi2000 通过前面板控件而非用户界面软件控制时）：**

- 1) 长按旋钮 2 秒即可解锁。



长按2秒解锁前面板控件

- **如需调节全局输出音量：**

- 1) 确保 LCD 显示屏已退回至主页面。
- 2) 顺时针旋转旋钮以调高音量，或逆时针旋转以调低音量。



顺时针旋转调高音量。

- **如需在菜单页面中导航子菜单或参数：**

- 1) 轻按菜单按键（2 @ 前面板），切换 LCD 页面至菜单页面。
- 2) 旋转旋钮选择需查看或编辑的子菜单。
- 3) 短按旋钮进入下一级菜单或确认当前参数设置。



旋转以导航至各子菜单或参数。



短按以确认参数编辑或导航至下一级菜单。

后面板

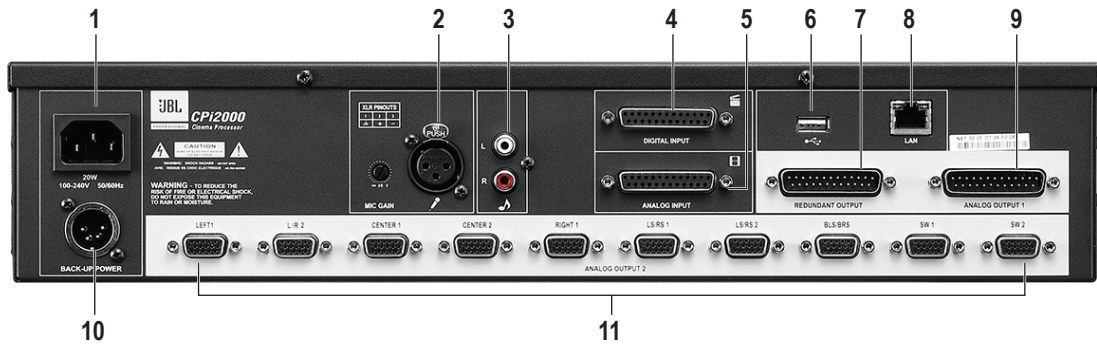

1. 交流电源输入

该交流电源输入接口的电源要求为 100-240VAC 50-60Hz 20W。请使用厂商提供的交流电源线连接该接口。



注意：安装设备或进行维修操作前，请确保设备电源已完全切断（即设备电源线已与电源插座断开）。



注意：如遇雷雨天气或设备长时间停机，请拔下电源插头。

2. 话筒输入

该话筒输入采用 XLR 接口，通常用于连接 RTA 话筒进行系统音频均衡设置，可输入平衡或非平衡信号，增益调节范围为 $-\infty$ dB - 40 dB。该话筒输入设有 +12V 幻象电源，可通过用户界面软件开启或关闭。

轻按话筒输入按键（4 @ 前面板），该话筒输入端口的输入信号将被选用。

3. 音乐（非同步）输入

该音乐（非同步）输入采用一对 RCA 接口，用于连接 CD 或 DVD 播放器等设备，输入立体声信号。

轻按音乐（非同步）输入按键（6 @ 前面板），该音乐（非同步）输入端口的输入信号将被选用。

4. 数字输入 [DIGITAL INPUT]

该数字输入采用 HD-25 接口（母头），用于连接影院影音服务器。该输入接口可输入最高 7.1 声道音频信号，支持 PCM 音频 @ 96、48、44.1、32kHz（16、20 或 24 位）与 Dolby Digital 音频（@ 所有数据位与采样率）格式。

5. 模拟输入 [ANALOG INPUT]

该模拟输入采用 HD-25 接口（母头），支持 8 通道输入，用于外接 $300\text{mV}_{\text{RMS}}$ （参考）输入信号。

6. USB 接口

该接口采用 A 类 USB 接口，用于连接 USB 闪存盘，进行预设文件保存或加载。

7. 冗余输出【REDUNDANT OUTPUT】

该冗余输出采用 HD-25 接口（公头），用于出现运行故障时旁通设备系统，将音频信号直接输出至下游设备。（注意：冗余输出端口必须与模拟输入【ANALOG INPUT】（5 @ 后面板）同时使用。）

8. 局域网端口【LAN】

该局域网端口采用 RJ45 接头，带 LED 指示灯，可用于 TMS（Theatre Management System，影院管理系统）系统通讯，或用于连接控制电脑，进行用户界面软件操作或固件更新。

9. 模拟输出 1【ANALOG OUTPUT 1】

该模拟输出 1 采用 HD-25 接口（公头），支持 8 通道输出，用于连接第三方音频系统。

10. 备用直流电输入【BACKUP DC】

该接口采用 4 - 针式 XLR 接口，用于连接 Cat. No.994 外接电源。该备用电源接口应连接 +12V 2A 直流电源转换器（如需购买，请咨询产品经销商或厂商）。

11. 模拟输出 2【ANALOG OUTPUT 2】

该模拟输出 2 包含 10 个 HD-15 公头接口（左 1、左 / 右 2、中 1、中 2、右 1、左环绕 / 右环绕 1、左环绕 / 右环绕 2、左后环绕 / 右后环绕、超低 1、超低 2），支持连接 CROWN 影院功放，用于模拟音频输出与故障信号输入。所有接口的配置需通过用户界面软件进行操作。

安装连接

安装



注意：安装设备前，请确保设备电源已完全切断（即设备电源线已与电源插座断开）。



注意：确保所有机架安装设备均接地良好。

CPi2000采用2U机身设计，可直接放置于水平稳固的作业台面或固定安装于标准机架。

如采用机架安装，应使用固定螺丝，将设备前面板固定于机架。见图“机架安装”。

为避免噪音干扰，应将设备远离功放安装。为确保通风良好，设备上方与下方应留出1U的开放空间，并确保所有通风口均无阻塞。

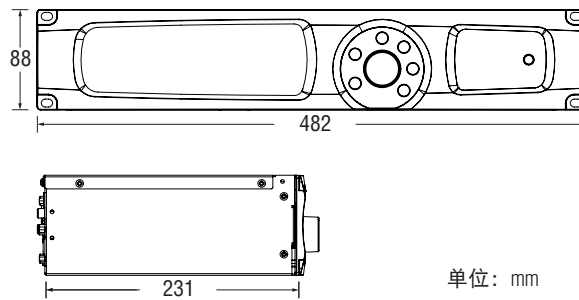

尺寸

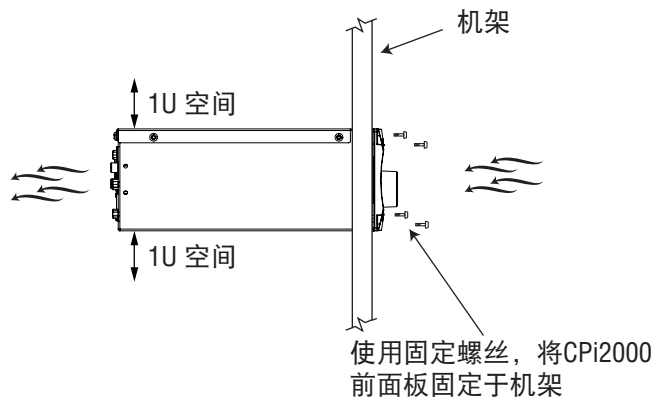

机架安装

快速连接



注意：连接前，请确保所有设备电源已关闭。



注意：连接前，请确保所有设备的音量控件均调至最低位。



注意：开启或关闭系统中的功放时，应遵循“后开先关”原则。

如需快速搭建影院音频系统，请参考下方步骤与“快速连接示例”图进行操作：

1. 连接输入设备，如话筒、CD/DVD 播放器、影音服务器、控制电脑等。
2. 连接输出设备，如功放、扬声器等。
3. 连接设备电源。
4. 开启所有设备电源。

完成上述步骤后，使用CPi2000专用户界面软件即可对整个音频系统进行详细设置，并通过前面板控件与LCD显示屏对系统状态进行监控。

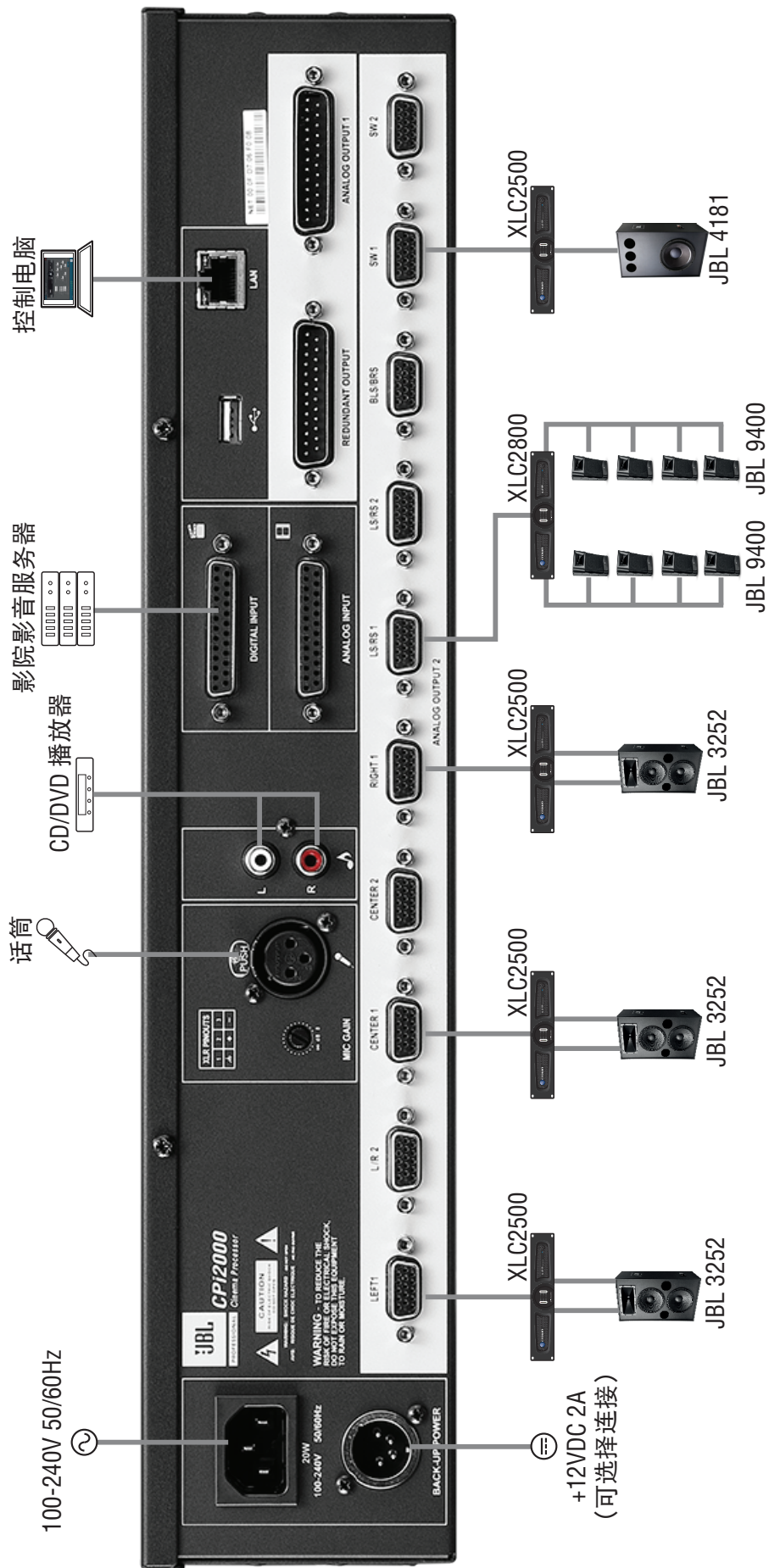

注意：连接前，请确保所有设备电源已关闭。

注意：连接前，请确保所有设备的音量控件均调至最低位。

注意：开启或关闭系统中的功放时，应遵循“后先关”原则。

快速连接示例

重置

使用前面板控件可快速将CPi2000重置至出厂设置。该重置操作仅将设备的固件恢复至出厂状态，不对用户的各项参数设置造成影响（但不含IP地址设置）。

CPi2000重置步骤：

1. 同时按住**话筒输入按键**（4 @ 前面板）与**哑音按键**（8 @ 前面板）。
2. 开启**电源按键**（7 @ 前面板）。
3. 持续按住**话筒输入按键**与**哑音按键**约10秒，直至LCD显示屏显示“RESTORING FACTORY RESETTINGS NOW”（正在恢复出厂设置）。



正在恢复出厂设置

4. 释放按键，等候约20秒，直至CPi2000完成重置与重启。
5. 当LCD显示主页面，则表示设备已准备就绪。



主页面

面板菜单结构



连接器针脚定义

1. 备用直流电输入 [BACKUP DC]

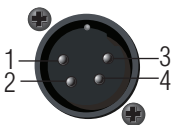
|  | XLR 针脚 | 连接 |
|---|--------|---------|
| | 1 | +12V 输入 |
| | 2 | +12V 输入 |
| | 3 | 接地 |
| | 4 | 接地 |
| 5 (外壳) | 接地 | |

2. 话筒输入

|  <p>(用于连接平衡话筒输入)</p> | XLR接头 (公头) | 连接 | 如需连接非平衡信号，连接针脚1至针脚3。 |
|---|------------|-------|----------------------|
| | 1 | 接地/屏蔽 | |
| | 2 | 热端(+) | |
| | 3 | 冷端(-) | |

3. 数字输入 [DIGITAL INPUT]

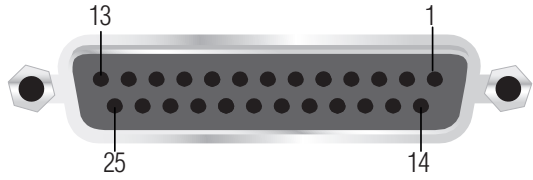
|  <p>(母头)</p> | HD-25 接头 | 连接 |
|---|---------------|---------------|
| | 1 | AES common |
| | 2 | CH 1/2 - |
| | 3 | CH 3/4 + |
| | 4 | AES common |
| | 5 | CH 5/6 - |
| | 6 | CH 7/8 + |
| | 7 | AES common |
| | 8 | No connection |
| | 9 | AES common |
| | 10 | No connection |
| | 11 | No connection |
| | 12 | AES common |
| | 13 | No connection |
| | 14 | CH 1/2 + |
| | 15 | AES common |
| | 16 | CH 3/4 - |
| | 17 | CH 5/6 + |
| | 18 | AES common |
| | 19 | CH 7/8 - |
| | 20 | AES common |
| | 21 | No connection |
| | 22 | No connection |
| | 23 | AES common |
| | 24 | No connection |
| 25 | No connection | |

4. 模拟输入 [ANALOG INPUT] /模拟输出1 [ANALOG OUTPUT 1] /冗余输出 [REDUNDANT OUTPUT]

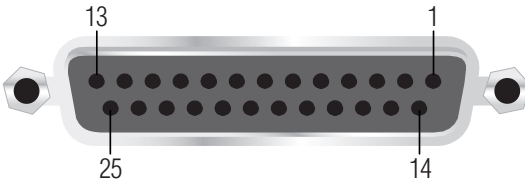
|  (模拟输入 - 母头) | HD-25 接头 | 连接 |
|--|----------|-------|
| | | 1 |
| | 2 | L + |
| | 3 | BLS - |
| | 4 | GND |
| | 5 | C + |
| | 6 | BRS - |
| | 7 | GND |
| | 8 | R + |
| | 9 | GND |
| | 10 | LS - |
| | 11 | RS - |
| | 12 | SW - |
| | 13 | GND |
| | 14 | L - |
| | 15 | GND |
| | 16 | BLS + |
| | 17 | C - |
| | 18 | GND |
| | 19 | BRS + |
| | 20 | R - |
| | 21 | GND |
| | 22 | GND |
| | 23 | LS + |
| | 24 | RS + |
| | 25 | SW + |

5. 模拟输出2 [ANALOG OUTPUT 2] (10 x HD-15接头)

|  (母头) | HD-15 接头 | 连接 |
|---|----------|--------------------------|
| | | 1 |
| | 2 | Null |
| | 3 | Null |
| | 4 | CH 1 Amp Status |
| | 5 | CH 1 Load Current Status |
| | 6 | Null |
| | 7 | CH 1 Output + |
| | 8 | CH 2 Output + |
| | 9 | Null |
| | 10 | GND |
| | 11 | CH 2 Output - |
| | 12 | Null |
| | 13 | Null |
| | 14 | CH 2 Amp Status |
| | 15 | CH 2 Load Current Status |

模拟输出2 [ANALOG OUTPUT 2] 通道分配

| HD-15 接头 | 三线分音 | | 双线分音 | | 被动 | |
|-------------|------|-----------|------|-----------|-----|--------|
| | 通道 | 输出 | 通道 | 输出 | 通道 | 输出 |
| LEFT 1 | CH1 | Left MF | CH1 | Left LF | CH1 | Left |
| | CH2 | Left HF | CH2 | Left HF | CH2 | Right |
| L/R 2 | CH1 | Left LF | CH1 | Null | CH1 | Null |
| | CH2 | Right LF | CH2 | Null | CH2 | Null |
| CENTER 1 | CH1 | Center MF | CH1 | Center LF | CH1 | Center |
| | CH2 | Center HF | CH2 | Center HF | CH2 | Null |
| CENTER 2 | CH1 | Center LF | CH1 | Null | CH1 | Null |
| | CH2 | Null | CH2 | Null | CH2 | Null |
| RIGHT 1 | CH1 | Right MF | CH1 | Right LF | CH1 | Null |
| | CH2 | Right HF | CH2 | Right HF | CH2 | Null |
| LS / RS 1 | CH1 | LS | CH1 | LS | CH1 | LS |
| | CH2 | RS | CH2 | RS | CH2 | RS |
| LS / RS 2 | CH1 | LS | CH1 | LS | CH1 | LS |
| | CH2 | RS | CH2 | RS | CH2 | RS |
| BLS / BRS | CH1 | BLS | CH1 | BLS | CH1 | BLS |
| | CH2 | BRS | CH2 | BRS | CH2 | BRS |
| SW 1 | CH1 | SW | CH1 | SW | CH1 | SW |
| | CH2 | SW | CH2 | SW | CH2 | SW |
| SW 2 | CH1 | SW | CH1 | SW | CH1 | SW |
| | CH2 | SW | CH2 | SW | CH2 | SW |

规格参数

| 输入 | | |
|----------------|-------------------------|---------------------------------|
| 数字输入 | 接口 | 平衡HD-25 (母头) |
| | 阻抗 | 110 Ohms |
| | 输入电平 | 0.5 - 10 Vpp |
| 模拟输入 | 接口 | 平衡或非平衡HD-25 (母头) |
| | 阻抗 | 50K Ohms (平衡) 或 25K Ohms (非平衡) |
| | 最高输入电平 | +14.2 dBu |
| 话筒输入 | 接口 | 平衡或非平衡XLR (母头) |
| | 阻抗 | 660 Ohms (平衡) 或 330 Ohms (非平衡) |
| | 总增益 | 40 dB |
| | E.I.N. | >113dB, 20K Hz 带宽 |
| 音乐 (非同步) 输入 | 接口 | RCA |
| | 阻抗 | 25K Ohms |
| | 最高输入电平 | +14.2 dBu |
| 输出 | | |
| 模拟输出1 & 冗余输出 | 接口 | 平衡或非平衡HD-25 (公头) |
| | 阻抗 | 30 Ohms (平衡) 或 15 Ohms (非平衡) |
| | 最高音量 | +14.2 dBu |
| | 频率响应 | 20 Hz - 20K Hz, 参考 1K Hz +/-1dB |
| | 总谐波失真 + 噪音 | <0.01%, 20 Hz - 20K Hz |
| | 动态范围 | >102 dB |
| 模拟输出2 | 接口 | 10 x 平衡或非平衡HD-15 (母头) |
| | 阻抗 | 30 Ohms (平衡) 或 15 Ohms (非平衡) |
| | 最高音量 | +14.2 dBu |
| | 频率响应 | 20 Hz - 20K Hz, 参考 1K Hz +/-1dB |
| | 总谐波失真 + 噪音 | <0.01%, 20 Hz - 20K Hz |
| | 动态范围 | >102 dB |
| 电源 | | |
| 交流电源输入 | 100-240VAC, 50-60Hz | |
| 直流电源输入 | +12VDC, 2A | |
| 常规 | | |
| 机架空间 | 2U | |
| 尺寸 (W x H x D) | 482 mm x 88 mm x 231 mm | |
| 净重 | 4.0 kg | |
| 运输重量 | 5.6 kg | |

