

Fixed Bumper

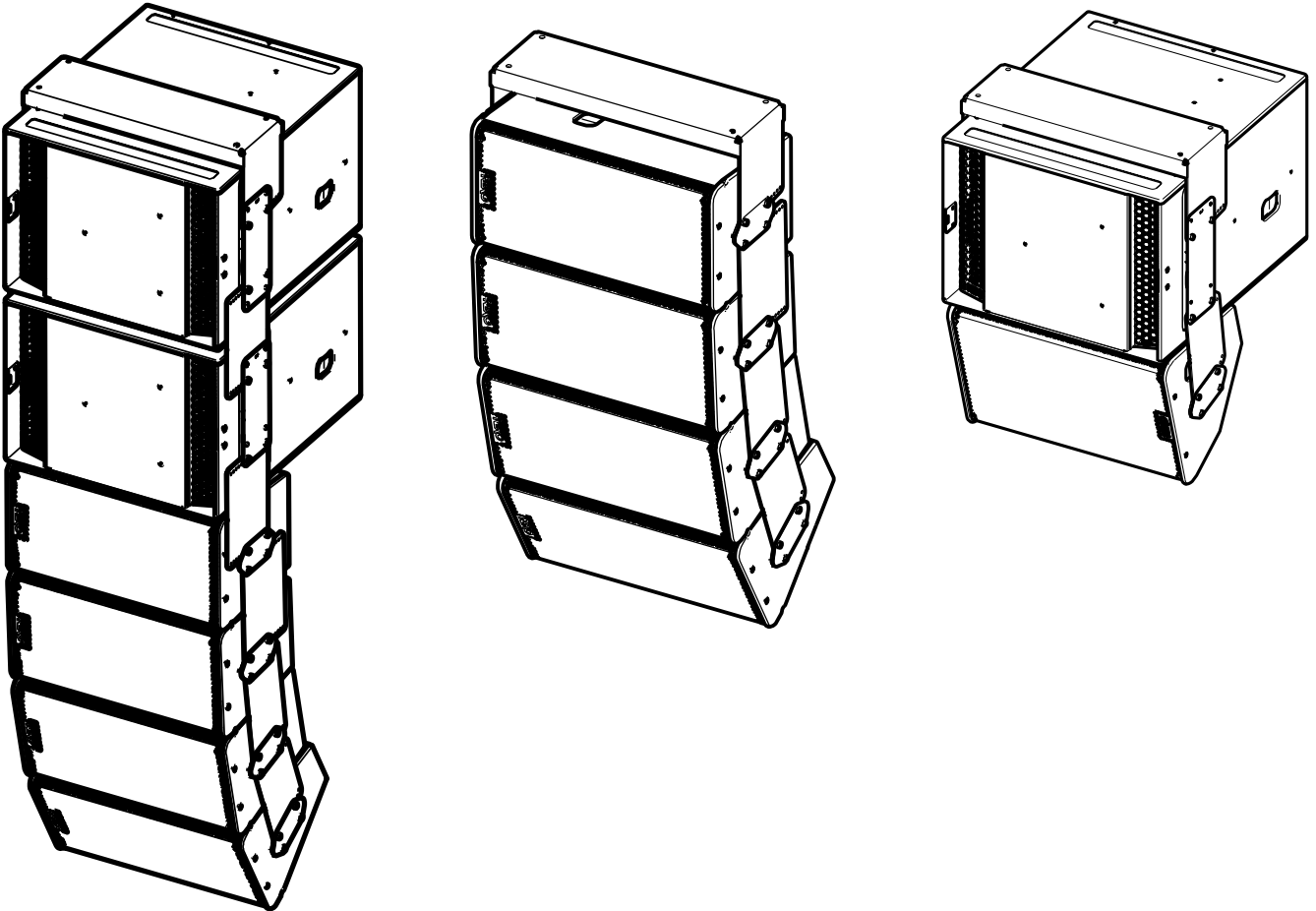
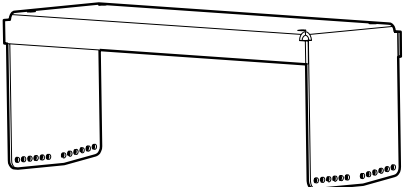
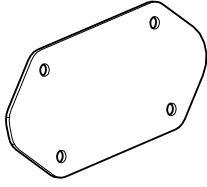
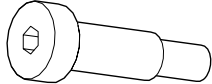

Contents:

<p>X1</p> 	<p>X4 (CPLA)</p> 	<p>X4 (D8x20 M6)</p> 
---	--	--

Weight: 14.5 kg / 32 lb

Dimensions:

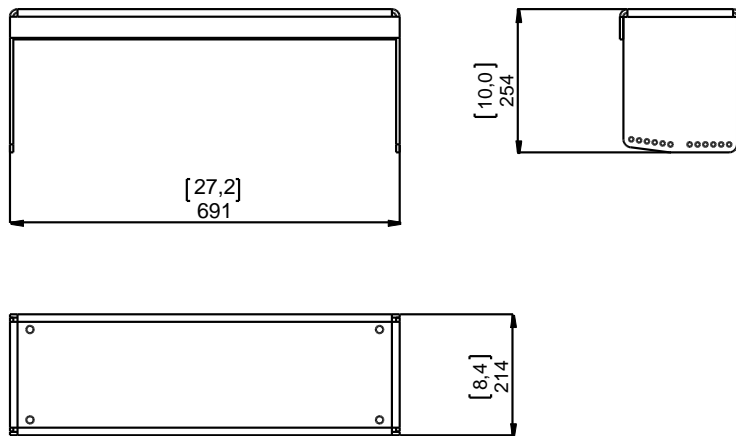

Angles:

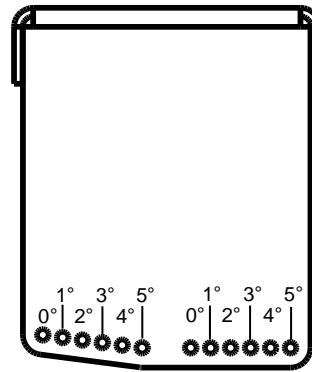

Assembly:

- 1) Remove the 4 Torx Screws holding connector plate, and replace with CPLA.
- 2) Insert BUMPER (adjust the angle), CPLA (and/or LSI-CPLA), and tighten.

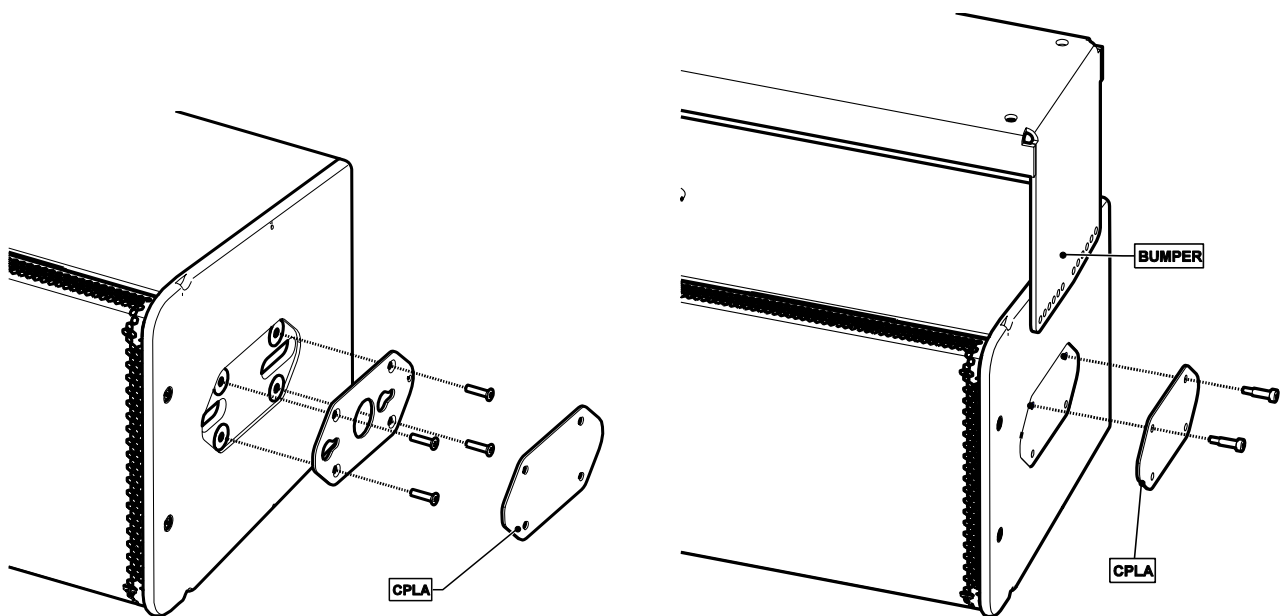

Warning:

- **Use only provided screws (thread lock coated or use Loctite 243).**
- **Be sure that the mounting location and fastener can bear at least 4 times the weight of the of all installed cabinets, auxiliary equipment and cables.**
- **NEXO cannot accept responsibility for accidents caused by any factor other than defects in this product itself.**
- **Please check the web site www.nexo-sa.com for the latest update.**

NEXO

www.nexo-sa.com
ZA du pre de la Dame Jeanne
60128 PLAILLY-France

- Read this document before using.
- Keep this document.
- Observe all warnings and cautions.