

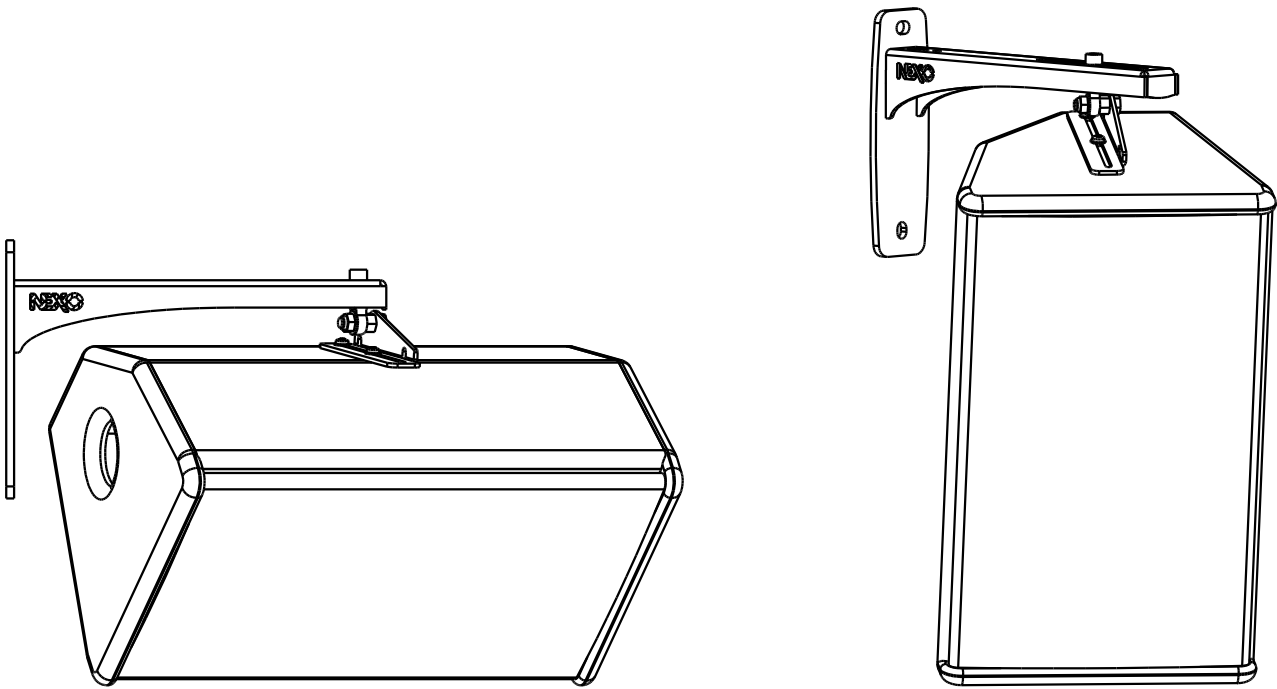

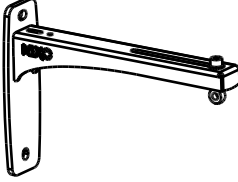

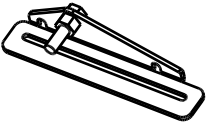

## PS8 Wall Bracket



### Contents:

<p>X1 (Arm)</p> 	<p>X1 (Adapter)</p> 	<p>X2</p> 
<p>X1</p> 	<p>X2</p> 	<p>X1</p> 
<p>X1</p> 	<p>X2</p> 	

Weight: 1.2 kg / 2.7 lb

## Dimensions:

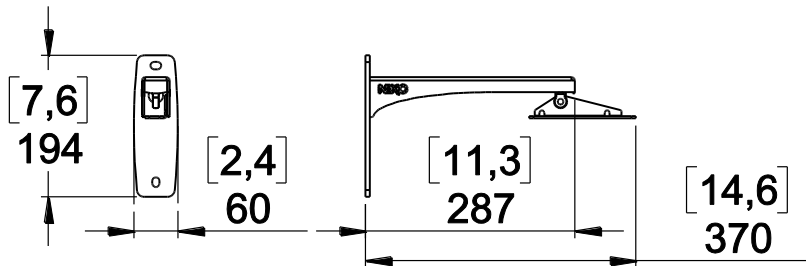

## Adapter mounting

- Remove 2 screws from the PS8 and use the 2 screws and the 2 washers provided to fix the adapter.
- Please, do not push on the 2 screws while screwing them, to avoid disengaging the bolt that is inside the cabinet.
- **WARNING:** Screws must be secured using Loctite 243™

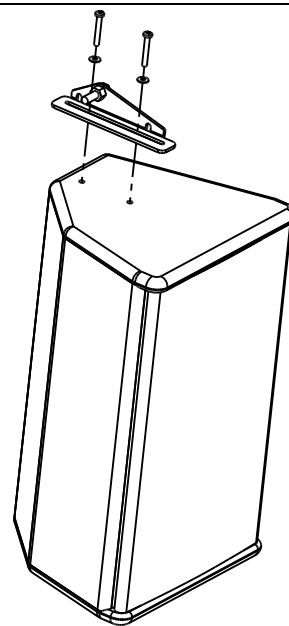

## Tilt in vertical position

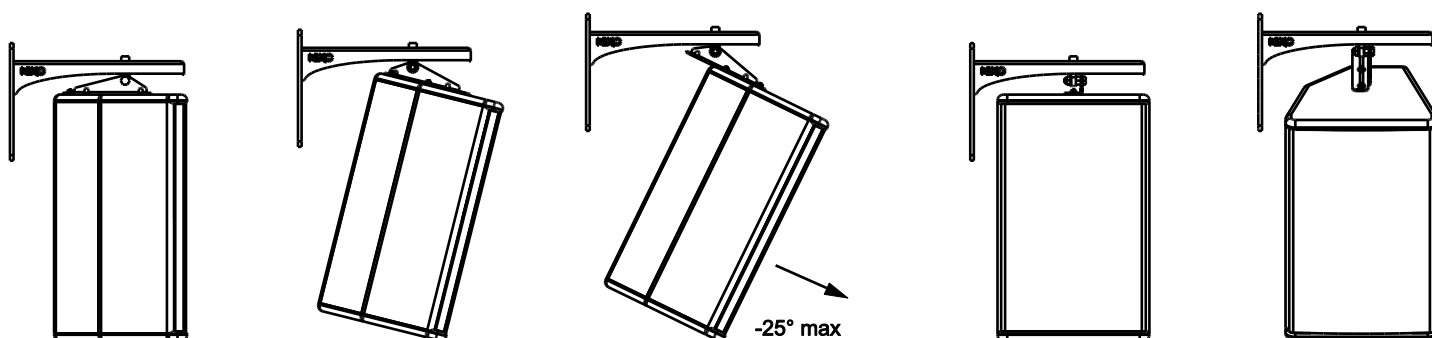

# NEXO

nexo-sa.com

ZA du Pre de la Dame Jeanne  
60128 PLAILLY - France

- Read this document before using.
- Keep this document.
- Observe all warnings and cautions.



## Tilt in horizontal position

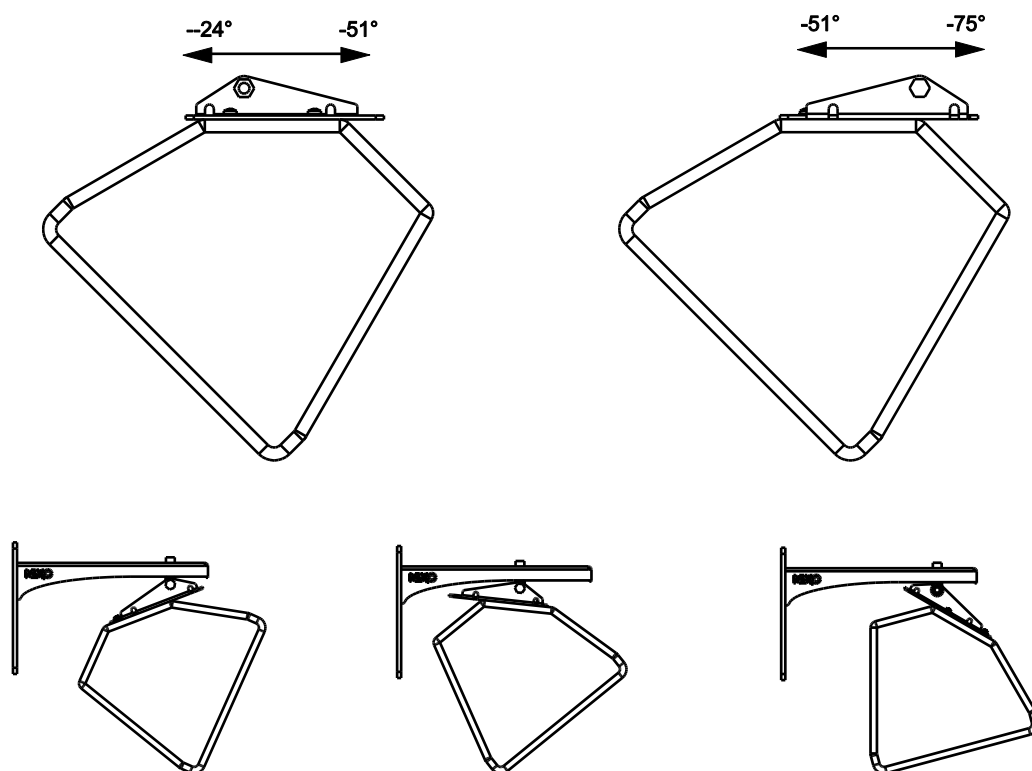

## Adapter / Arm mounting

*For the wall mount of VNI-WS8, please select screws and mounting location supporting 4 times the system weight.*

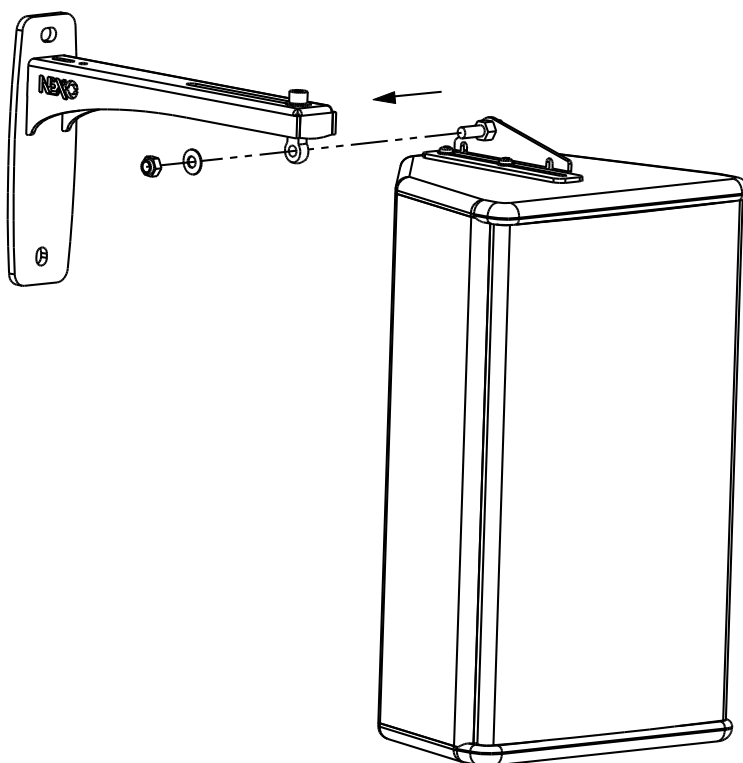

**Tighten well to cancel any float between the arm and the adapter.**

# NEXO

nexo-sa.com  
ZA du Pre de la Dame Jeanne  
60128 PLAILLY - France

- Read this document before using.
- Keep this document.
- Observe all warnings and cautions.



## Safety device

Use the parts provided

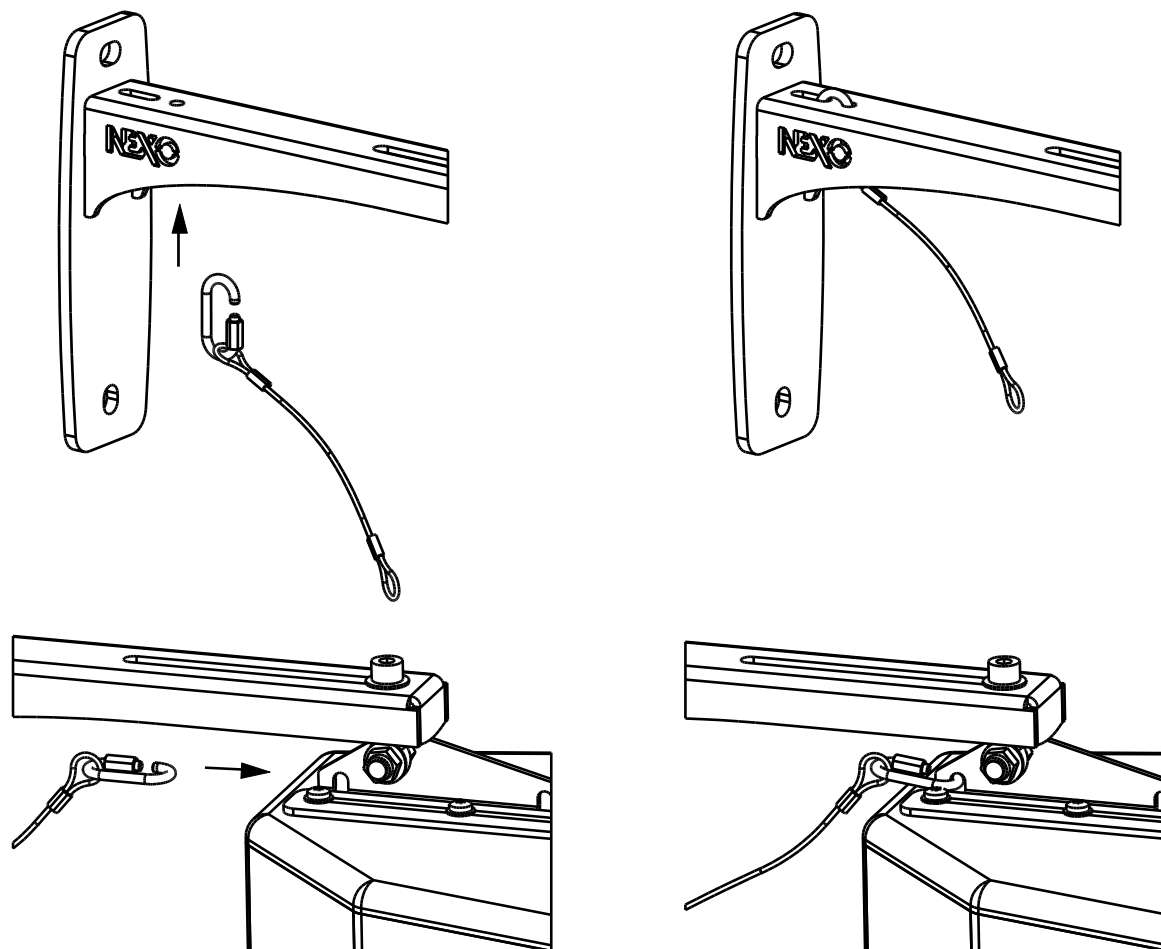

- NEXO cannot accept responsibility for accidents caused by any factor other than defects in this product itself.
- Please check the web site [nexo-sa.com](http://nexo-sa.com) for the latest update.

# NEXO

[nexo-sa.com](http://nexo-sa.com)

ZA du Pre de la Dame Jeanne  
60128 PLAILLY - France

- Read this document before using.
- Keep this document.
- Observe all warnings and cautions.

