

Sonus Bar 8

Product code: 41272

Preface

Thank you for purchasing this Showtec product.

The purpose of this user manual is to provide instructions for the correct and safe use of this product.

Keep the user manual for future reference as it is an integral part of the product. The user manual shall be stored at an easily accessible location.

This user manual contains information concerning:

- Safety instructions
- Intended and non-intended use of the device
- Installation and operation of the device
- Maintenance procedures
- Troubleshooting
- Transport, storage and disposal of the device

Non-observance of the instructions in this user manual may result in serious injuries and damage of property.

©2025 Showtec. All rights reserved.

No part of this document may be copied, published or otherwise reproduced without the prior written consent of Highlite International.

Design and product specifications are subject to change without prior notice.

For the latest version of this document or other language versions, please visit our website www.highlite.com or contact us at service@highlite.com.

Highlite International and its authorized service providers are not liable for any injury, damage, direct or indirect loss, consequential or economic loss or any other loss arising from the use of, or inability to use or reliance on the information contained in this document.

Highlite International B.V. – Vestastraat 2 – 6468 EX Kerkrade – the Netherlands

Table of contents

1. Introduction	4
1.1. Before Using the Product.....	4
1.2. Intended Use.....	4
1.3. LEDs Lifespan.....	4
1.4. Product Lifespan.....	4
1.5. Text Conventions.....	5
1.6. Symbols and Signal Words.....	5
1.7. Symbols on the Information Label.....	5
2. Safety	6
2.1. Warnings and Safety Instructions.....	6
2.2. Requirements for the User.....	8
2.3. Personal Protective Equipment.....	8
3. Description of the Device	9
3.1. Front view.....	9
3.2. Back View.....	9
3.3. Product Specifications.....	10
3.4. Dimensions.....	11
3.5. Optional Accessories.....	11
4. Installation	12
4.1. Safety Instructions for Installation.....	12
4.2. Personal Protective Equipment.....	12
4.3. Installation Site Requirements.....	12
4.4. Rigging.....	12
4.5. Angle Adjustment.....	13
4.6. Connecting to Power Supply.....	13
4.7. Power Linking of Multiple Devices.....	14
5. Setup	15
5.1. Warnings and Precautions.....	15
5.2. Stand-alone Setup.....	15
5.3. DMX Connection	15
5.3.1. DMX-512 Protocol.....	15
5.3.2. DMX Cables.....	16
5.3.3. Master/Slave Setup.....	16
5.3.4. DMX Linking.....	17
5.3.5. DMX Addressing.....	17
6. Operation	18
6.1. Safety Instructions for Operation.....	18
6.2. Control Modes.....	18
6.3. Control Panel.....	19
6.4. Start-up.....	19
6.5. Menu Overview.....	20
6.6. Main Menu Options.....	21
6.6.1. Auto Mode.....	21
6.6.2. Program mode.....	21
6.6.2.1. Program 01.....	22
6.6.2.2. Program 02–24.....	22
6.6.3. Color mode.....	22
6.6.4. Sound Mode.....	22
6.6.5. Settings.....	23
6.6.5.1. Dimmer Curve.....	23
6.6.5.2. Backlight Time.....	24
6.6.5.3. Pixel Direction.....	24
6.6.5.4. DMX Fail.....	24
6.6.5.5. Display Lock.....	24
6.6.5.6. Default Factory Settings.....	24
6.6.6. Info.....	25
6.6.7. DMX Mode.....	25

6.6.8. Slave Mode.....	25
6.7. Remote Control.....	26
6.7.1. Remote Control Mode.....	26
6.7.2. Functions of the Remote Control Buttons.....	27
6.7.3. Remote Control Operation.....	28
6.7.3.1. IR Auto Mode.....	28
6.7.3.2. IR Program Mode.....	28
6.7.3.3. IR Sound Mode.....	28
6.7.3.4. IR Color Mode.....	29
6.7.3.5. IR Preset Colors.....	29
6.7.3.6. IR Strobe.....	29
6.7.3.7. IR Factory Reset.....	29
6.8. DMX Channels.....	30
6.8.1. DMX Channels Overview.....	30
6.8.2. RGBW (4 CH), Pixel (32 CH).....	31
6.8.3. Basic (6 CH), Extended (34 CH), Auto (6 CH), Basic Auto (10 CH), Extended Auto (38 CH).....	32
6.9. RDM Information.....	35
6.9.1. RDM Details.....	35
6.9.2. Supported RDM PIDs (Parameter IDs).....	35
7. Troubleshooting.....	36
8. Maintenance.....	37
8.1. Safety Instructions for Maintenance.....	37
8.2. Preventive Maintenance.....	37
8.2.1. Basic Cleaning Instructions.....	37
8.3. Corrective Maintenance.....	37
9. Deinstallation, Transportation and Storage.....	38
9.1. Instructions for Deinstallation.....	38
9.2. Instructions for Transportation.....	38
9.3. Storage.....	38
10. Disposal.....	38
11. Approval.....	38

1. Introduction

1.1. Before Using the Product

**Important**

Read and follow the instructions in this user manual before installing, operating or servicing this product.

The manufacturer will not accept liability for any resulting damages caused by the non-observance of this manual.

After unpacking, check the contents of the box. If any parts are missing or damaged, contact your Highlite International dealer.

Your shipment includes:

- Showtec Sonus Bar 8
- Schuko to Power Pro cable (1,5 m)
- User manual

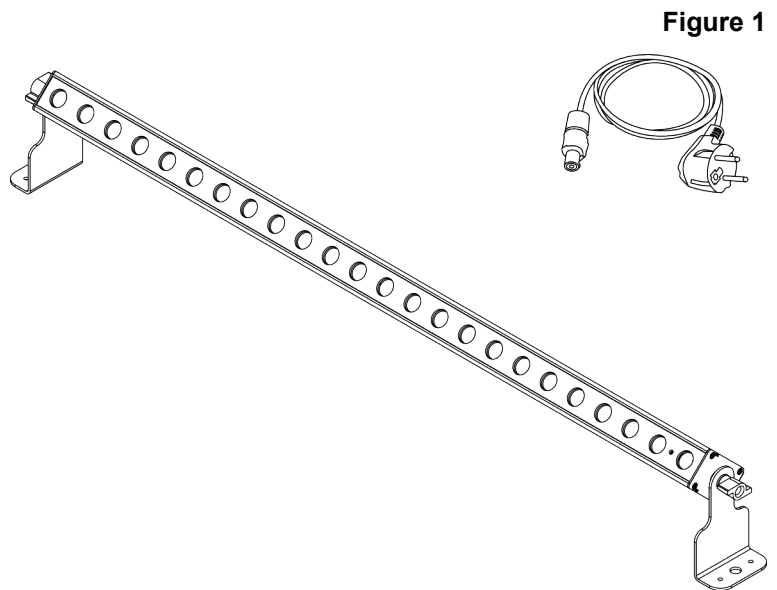

Figure 1

1.2. Intended Use

This device is intended for professional use as a stage light effect. It can be installed only indoors. This device is not suitable for households.

Any other use, not mentioned under intended use, is regarded as non-intended and incorrect use.

1.3. LEDs Lifespan

The light output of the LEDs gradually decreases over time (lumen depreciation). High operating temperatures contribute to this process. You can extend the lifespan of the LEDs by providing adequate ventilation and operating the LEDs at the lowest possible brightness.

1.4. Product Lifespan

This device is not designed for permanent operation.

Disconnect the device from the electrical power supply when the device is not in operation. This will reduce the wear and will improve the lifespan of the device.

1.5. Text Conventions

Throughout the user manual the following text conventions are used:

- Buttons: All buttons are in bold lettering, for example "Press the **UP/DOWN** buttons"
- References: References to parts of the device are in bold lettering, for example: "turn the **adjustment handle (05)**". References to chapters are hyperlinked
- 0–255: Defines a range of values
- Notes: **Note:** (in bold lettering) is followed by useful information or tips

1.6. Symbols and Signal Words

Safety notes and warnings are indicated throughout the user manual by safety signs.

Always follow the instructions provided in this user manual.



DANGER

Indicates an imminently hazardous situation which, if not avoided, will result in death or serious injury.



WARNING

Indicates a potentially hazardous situation which, if not avoided, could result in death or serious injury.



CAUTION

Indicates a potentially hazardous situation, which, if not avoided, may result in minor or moderate injury.



Attention

Indicates important information for the correct operation and use of the product.



Important

Read and observe the instructions in this document.



Electrical hazard



Provides important information about the disposal of this product.

1.7. Symbols on the Information Label

This product is provided with an information label. The information label is located on the back side of the device.

The information label contains the following symbols:



This device is designed for indoor use.



This device shall not be treated as household waste.



Read and follow the instructions in the user manual before installing, operating or servicing the device.



This device falls under IEC protection class I.

2. Safety



Important
Read and follow the instructions in this user manual before installing, operating or servicing this product.

The manufacturer will not accept liability for any resulting damages caused by the non-observance of this manual.

2.1. Warnings and Safety Instructions



DANGER
Danger for children

For adult use only. The device must be installed beyond the reach of children.

- Do not leave any parts of the packaging (plastic bags, polystyrene foam, nails, etc.) within the reach of children. Packaging material is a potential source of danger for children.



DANGER
Electric shock caused by dangerous voltage inside

There are areas inside the device where dangerous touch voltage may be present.

- Do not open the device or remove any covers.
- Do not operate the device if the covers or the housing are open. Before operation, check if the housing is firmly closed and all screws are tightly fastened.
- Disconnect the device from the electrical power supply before service and maintenance, and when the device is not in use.



DANGER
Electric shock caused by short-circuit

This device falls under IEC protection Class I.

- Make sure that the device is electrically connected to ground (earth). Connect the device only to a socket-outlet with a ground (earth) connection.
- Do not cover the ground (earth) connection.
- Do not bypass the thermostatic switch or fuses.
- Do not let the power cable come into contact with other cables. Handle the power cable and all connections with the mains with caution.
- Do not modify, bend, mechanically strain, put pressure on, pull or heat up the power cable.
- Make sure that the power cable is not crimped or damaged. Examine the power cable periodically for any defects.
- Do not immerse the device in water or other liquids. Do not install the device in a location where flooding may occur.
- Do not use the device during thunderstorms. Disconnect the device from the electrical power supply immediately.



WARNING
Risk of epileptic shock

Strobe lighting can trigger seizures in photosensitive epilepsy. Sensitive persons should avoid looking at strobe lights.



Attention
Power supply

- Before connecting the device to the power supply, make sure that the current, voltage and frequency match the input voltage, current and frequency specified on the information label on the device.
- Make sure that the cross-sectional area of the extension cords and power cables is sufficient for the required power consumption of the device.



Attention
General safety

- Do not connect the device to a dimmer pack.
- Do not switch the device on and off in short intervals. This reduces the device's life.
- Do not shake the device. Avoid brute force when installing or operating the device.
- Change the lens or the LEDs if they are visibly damaged to such an extent that their effectiveness is impaired, for example by cracks or deep scratches. Contact your Highlite International dealer for more information, as servicing can be performed only by instructed or skilled persons.
- If the device is dropped or struck, disconnect the device from the electrical power supply immediately.
- If the device is exposed to extreme temperature variations (e.g. after transportation), do not switch it on immediately. Let the device reach room temperature before switching it on, otherwise it may be damaged by the formed condensation.
- If the device fails to work properly, discontinue use immediately.



Attention
For professional use only
This device must be used only for the purposes it is designed for.

This device is intended for professional use as a stage light effect. Any incorrect use may lead to hazardous situations and result in injuries and material damage.

- This device is not suitable for households and for general lighting.
- This device is not designed for permanent operation.
- This device does not contain user-serviceable parts. Unauthorized modifications to the device will render the warranty void. Such modifications may result in injuries and material damage.



Attention
Before each use, examine the device visually for any defects.

Make sure that:

- All screws used for installing the device or parts of the device are tightly fastened and are not corroded.
- The safety devices are not damaged.
- There are no deformations on housings, fixings and installation points.
- The lens is not cracked or damaged.
- The power cables are not damaged and do not show any material fatigue.

**Attention****Do not expose the device to conditions that exceed the rated IP class conditions.**

This device is IP20 rated. IP (Ingress Protection) 20 class provides protection against solid objects greater than 12 mm, such as fingers, and no protection against harmful ingress of water.

2.2. Requirements for the User

This product may be used by ordinary persons. Maintenance may be carried out by ordinary persons. Installation and service shall be carried out only by instructed or skilled persons. Contact your Highlite International dealer for more information.

Instructed persons have been instructed and trained by a skilled person, or are supervised by a skilled person, for specific tasks and work activities associated with the installation, service and maintenance of this product, so that they can identify risks and take precautions to avoid them.

Skilled persons have training or experience, which enables them to recognize risks and avoid hazards associated with the installation, service and maintenance of this product.

Ordinary persons are all persons other than instructed persons and skilled persons. Ordinary persons include not only users of the product but also any other persons that may have access to the device or who may be in the vicinity of the device.

2.3. Personal Protective Equipment

During installation, deinstallation and rigging wear personal protective equipment in compliance with the national and site-specific regulations.

3. Description of the Device

The Showtec Sonus Bar 8 is a light bar with 24 RGBW LEDs of 2 W each. The LEDs can be controlled in up to 8 sections via up to 38 DMX channels. It can also work in stand-alone mode with built-in programs, sound-controlled programs, manual settings, in master/slave mode and it supports RDM. The Showtec Sonus Bar 8 is convection-cooled, so it is completely silent in operation.

3.1. Front view

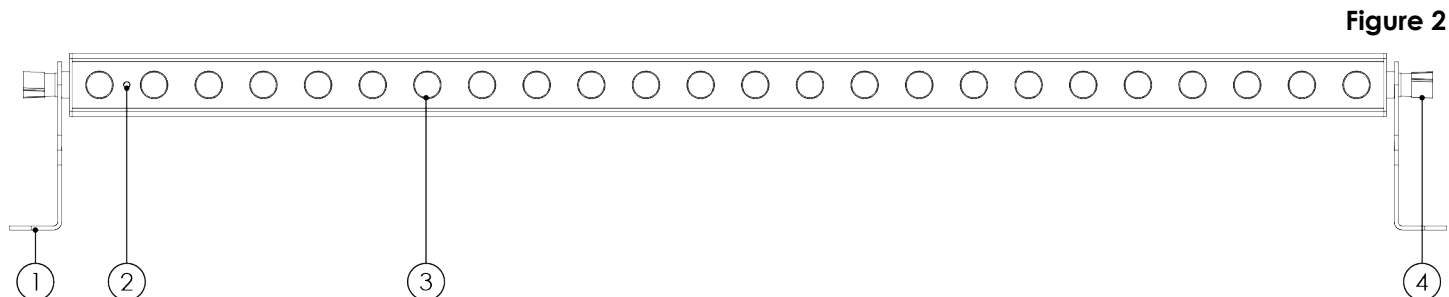

Figure 2

- 01) 2 x Mounting brackets
- 02) IR sensor
- 03) 24 x RGBW 4-in-1 2 W LEDs
- 04) 2 x Adjustment screws

3.2. Back View



Figure 3

- 05) 2 x Safety eyes
- 06) Power Pro connector OUT
- 07) 3-pin DMX signal connector OUT
- 08) Control panel: 7-segment display, control buttons and built-in microphone
- 09) Ground/earth connection
- 10) 3-pin DMX signal connector IN
- 11) Power Pro connector IN

3.3. Product Specifications

Model:	Sonus Bar 8
--------	-------------

Source:	
Light source type	LED
Light source quantity	24
Light source power	2 W
LED color type	RGBW
Refresh rate	1000 Hz
Luminous flux (total)	924 lm

Optical:	
Beam angle (horizontal)	16,4°
Beam angle (vertical)	11,3°

Control and Programming:	
Control mode	Built-in Program / DMX / Manual / Master Slave / Remote / RDM / Sound
DMX channels	4 / 6 / 6 / 10 / 32 / 34 / 38
Protocols	DMX / RDM
Display	7-segment

Dynamic Effects:	
Dimmer	0-100 %
Strobe	0-15 Hz

Electrical Specifications and Connections:	
Power supply	100-240 V AC 50/60 Hz
Power consumption	30 W
Power connector IN	Power Pro Blue
Power connector OUT	Power Pro Grey
DMX connector	XLR 3P IN/OUT
DMX connector IN	XLR 3P
DMX connector OUT	XLR 3P

Mechanical Specifications:	
Length	1.091 mm
Width	80 mm
Height	148 mm
Weight	3,1 kg
IP rating	IP20 (indoor use only)
Housing	Aluminum
Color	Black

Product Properties:	
Cooling	Convection

Rigging:	
Mounting options	Clamp

Thermal Specifications:	
Maximum ambient temperature	40 °C
Minimum operating temperature	-5 °C

Included Items:

Included cables Power Pro cable

3.4. Dimensions

Figure 4

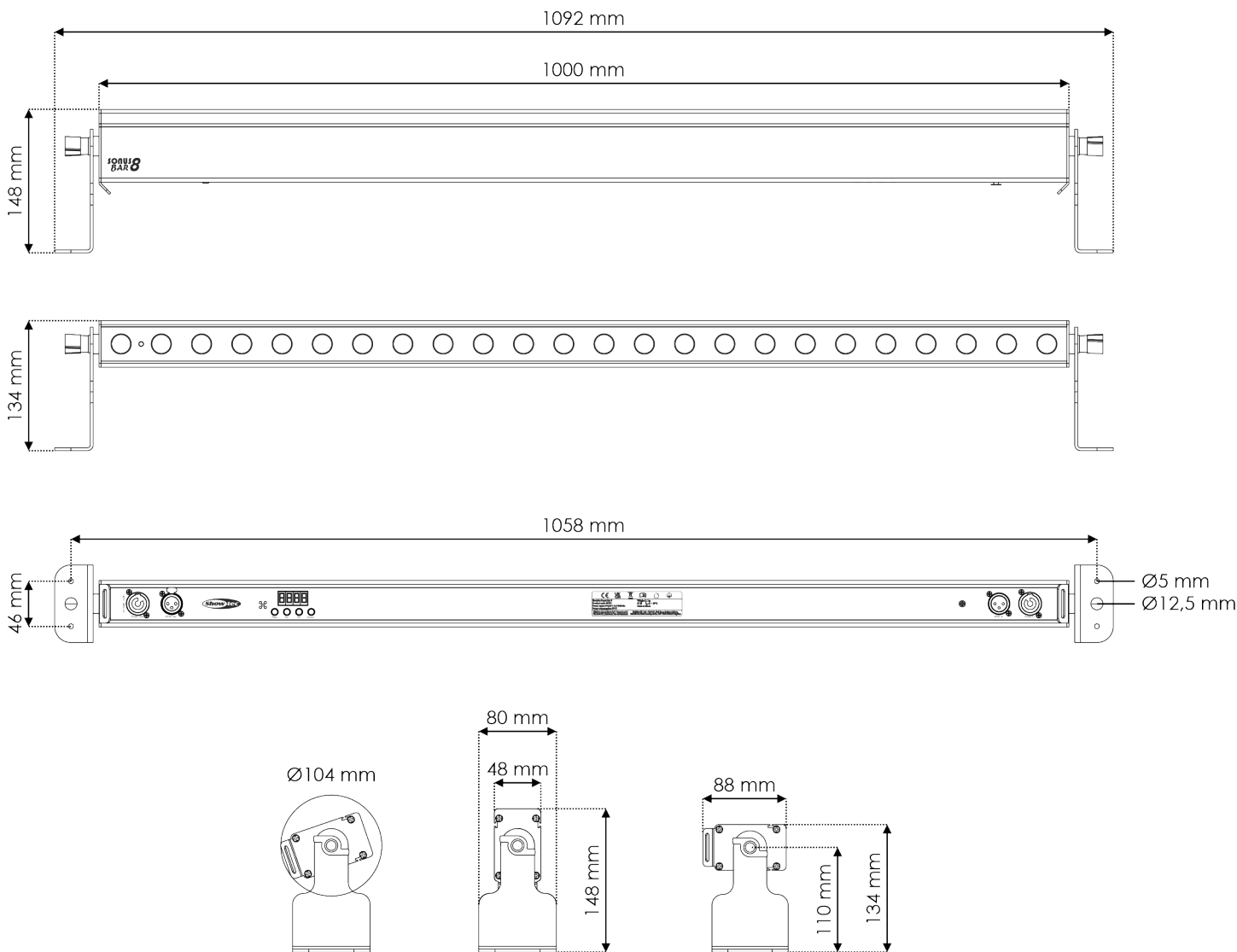

3.5. Optional Accessories

The IR remote control is not supplied with the device. Contact your Highlite International dealer for more information.

Product code: [44002](#) (Showtec UR-5 Universal IR Remote)

4. Installation

4.1. Safety Instructions for Installation



WARNING

Incorrect installation can cause serious injuries and damage of property.

If trussing systems are used, installation must be carried out only by instructed or skilled persons.

Follow all applicable European, national and local safety regulations concerning rigging and trussing.

4.2. Personal Protective Equipment

During installation, deinstallation and rigging wear personal protective equipment in compliance with the national and site-specific regulations.

4.3. Installation Site Requirements

- The device can be used only indoors.
- The minimum distance to other objects must be bigger than 0,5 m.
- The maximum ambient temperature $t_a = 40\text{ °C}$ must never be exceeded.
- The relative humidity must not exceed 50 % with an ambient temperature of 40 °C.

4.4. Rigging

The device can be positioned on a flat surface or mounted to a truss or other rigging structure in any orientation. Make sure that all loads are within the pre-determined limits of the supporting structure.



CAUTION

Restrict the access under the work area during rigging/derigging.

To mount the device, follow the steps below:

- 01) Use 2 clamps to attach the device to the supporting structure. Make sure that the device cannot move freely.
- 02) Secure the device with a secondary suspension, for example a safety cable. Make sure that the secondary suspension can hold 10 times the weight of the device. If possible, the secondary suspension should be attached to a supporting structure independent of the primary suspension. Put the safety cable through the **safety eye (05)**.

Figure 5
Safety cable

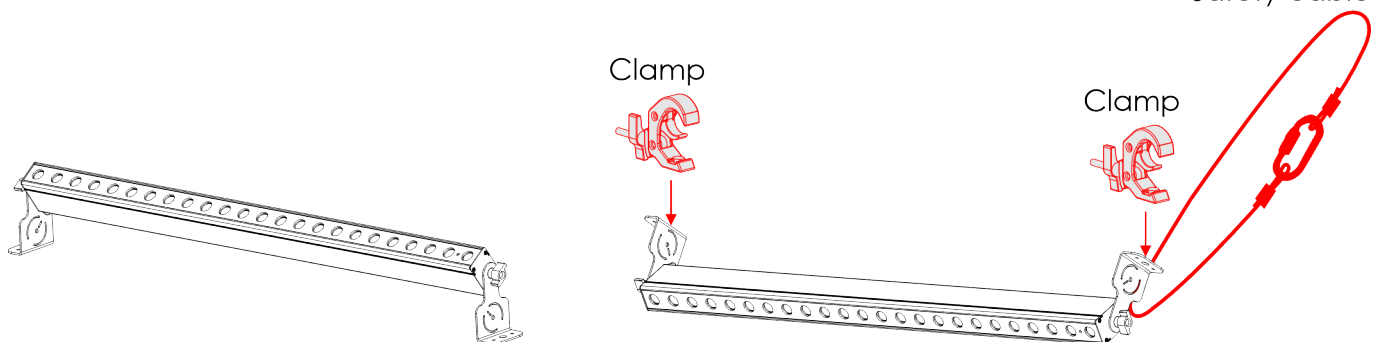

4.5. Angle Adjustment

You can adjust the angle of the device with the **adjustment screws (04)**.

- 01) Turn the **adjustment screws (04)** counterclockwise to loosen it.
- 02) Tilt the device to the desired angle.
- 03) Turn the **adjustment screws (04)** clockwise to tighten it. Make sure that the device cannot move freely after the **adjustment screws (04)** is tightened.

Figure 6

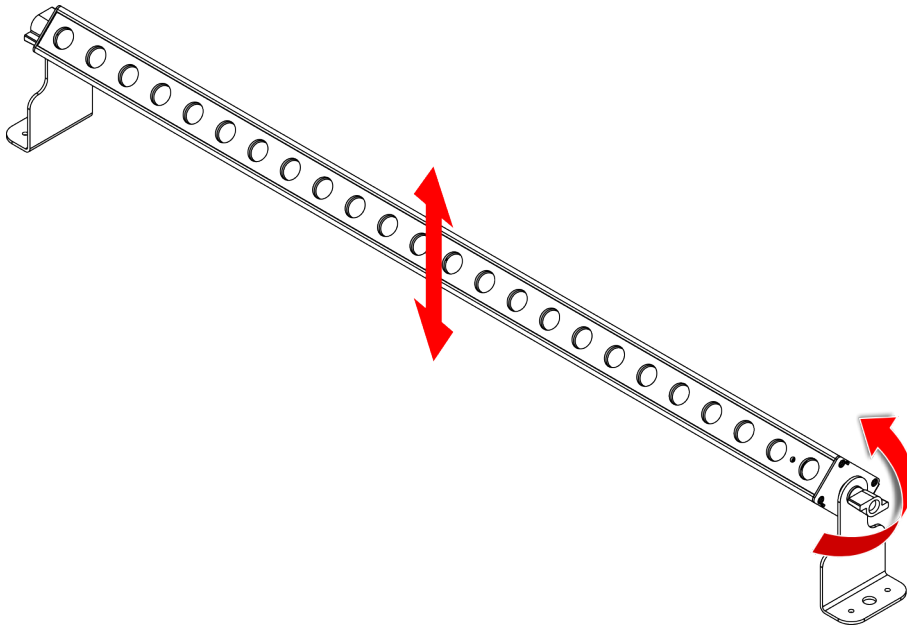

4.6. Connecting to Power Supply



DANGER
Electric shock caused by short-circuit

The device accepts AC mains power at 100–240 V and 50/60 Hz. Do not supply power at any other voltage or frequency to the device.

This device falls under IEC protection class I. Make sure that the device is always electrically connected to the ground (earth).

Before connecting the device to the socket-outlet:

- Make sure that the power supply matches the input voltage specified on the information label on the device.
- Make sure that the socket-outlet has a ground (earth) connection.

Connect the device to the socket-outlet with the power plug. Do not connect the device to a dimmer circuit, as this may damage the device.

4.7. Power Linking of Multiple Devices

This device supports power linking. Power can be relayed to another device via the power OUT connector. Note that the input and the output connectors have different designs: one type cannot be connected to the other.

Power linking of multiple devices must be carried out only by instructed or skilled persons.

**WARNING**

Incorrect power linking may lead to overload of the electrical circuit and result in serious injuries and damage of property.

To prevent overload of the electrical circuit, when power linking multiple devices:

- Use cables with sufficient current-carrying capacity. The power cable supplied with the device is not suitable for power linking of multiple devices.
- Make sure that the total current draw of the device and all connected devices does not exceed the rated capacity of the power cables and the circuit breaker.
- Do not link more devices on one power link than the maximum recommended number.

Maximum recommended number of devices:

- at 100–120 V: 23 devices Sonus Bar 8
- at 200–240 V: 46 devices Sonus Bar 8

5. Setup

5.1. Warnings and Precautions

**Attention**

Connect all data cables before supplying power.

Disconnect power supply before connecting or disconnecting data cables.

5.2. Stand-alone Setup

When the Sonus Bar 8 is not connected to a controller or to other devices, it functions as a stand-alone device. It can be operated manually via the control panel and the manual controls or via an optional remote control.

For more information refer to Control Modes (see [6.2. Control Modes](#) on page 18).

5.3. DMX Connection

5.3.1. DMX-512 Protocol

You need a DMX serial data link to run light shows of one or more devices using a DMX-512 controller.

The Sonus Bar 8 has 3-pin DMX signal IN and OUT connectors.

The pin assignment is as follows: pin 1 (ground), pin 2 (-), pin 3 (+).

Devices on a serial data link must be daisy-chained in a single line. The number of devices that you can control on one data link is limited by the combined number of the DMX channels of the connected devices and the 512 channels available in one DMX universe.

To comply with the TIA-485 standard, no more than 32 devices should be connected on one data link. In order to connect more than 32 devices on one data link, you must use a DMX optically isolated splitter/booster, otherwise this may result in deterioration of the DMX signal.

Note:

- Maximum recommended DMX data link distance: 300 m
- Maximum recommended number of devices on a DMX data link: 32 devices

5.3.2. DMX Cables

Shielded twisted-pair cables with 3-pin XLR connectors must be used for reliable DMX connection. You can purchase DMX cables directly from your Highlite International dealer or make your own cables.

If you use XLR audio cables for DMX data transmission, this may lead to signal degradation and unreliable operation of the DMX network.

When you make your own DMX cables, make sure that you connect the pins and wires correctly as shown in the figure below.

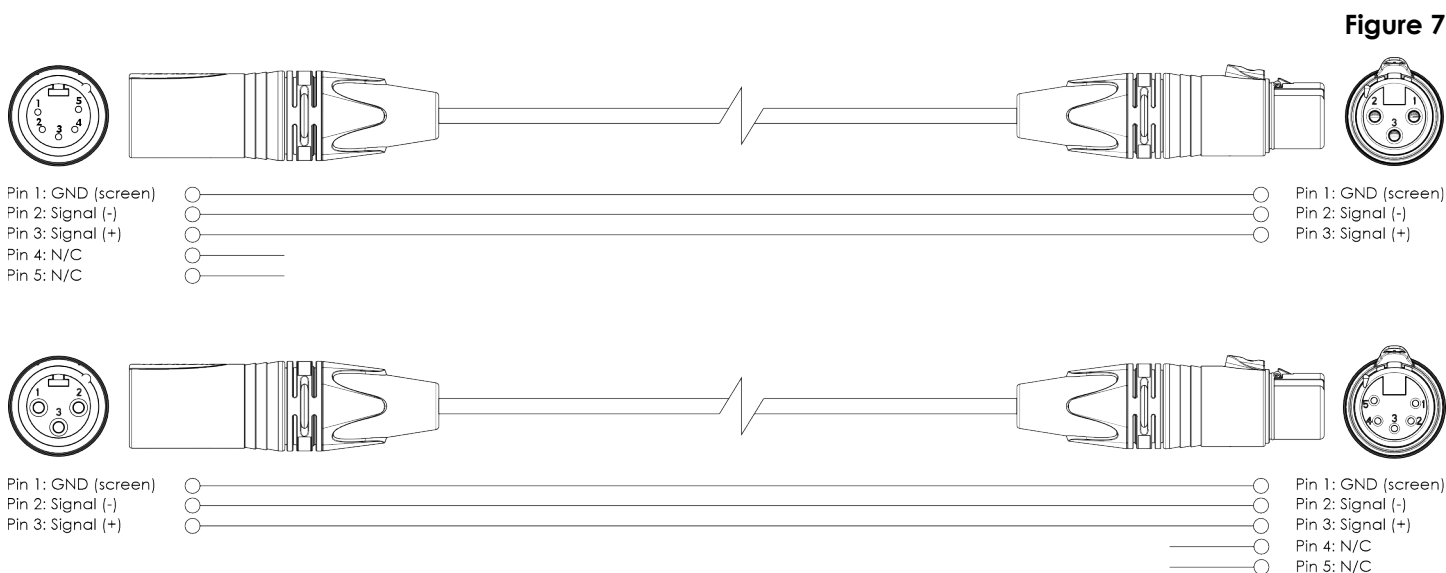

5.3.3. Master/Slave Setup

The Sonus Bar 8 supports master/slave control mode. To connect multiple devices in a master/slave setup, follow the steps below:

- 01) Connect the DMX OUT connector of the 1st device to the DMX IN connector of the 2nd device with a 3-pin DMX cable.
- 02) Repeat step 1 to connect all devices in a daisy-chain.
- 03) Connect a DMX terminator (120 Ω resistor) to the DMX OUT connector of the last device on the data link.
- 04) Set the 1st device on the data link as a master device. Refer to Slave Mode (see [6.6.8. Slave Mode](#) on page 25) for more information.
- 05) Select a slave setting for the other devices on the data link. Refer to Slave Mode (see [6.6.8. Slave Mode](#) on page 25) for more information.

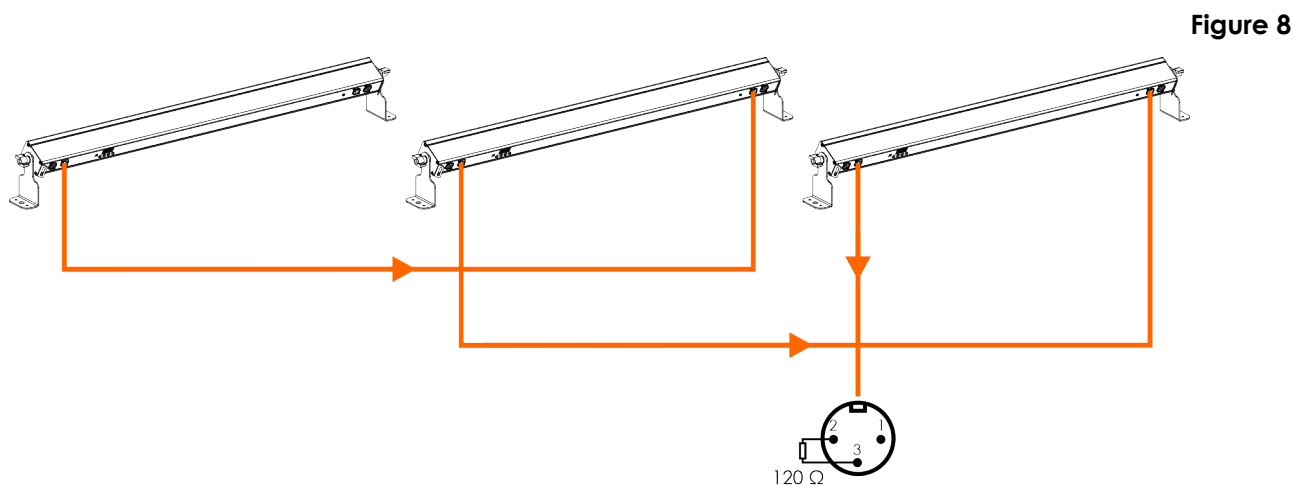

5.3.4. DMX Linking

To connect multiple devices on one DMX data link, follow the steps below:

- 01) Use a 3-pin DMX cable to connect the DMX OUT connector of the lighting controller to the DMX IN connector of the 1st device.
- 02) Connect the DMX OUT connector of the 1st device to the DMX IN connector of the 2nd device with a 3-pin DMX cable.
- 03) Repeat step 2 to connect all devices in a daisy-chain.
- 04) Connect a DMX terminator (120 Ω resistor) to the DMX OUT connector of the last device on the data link.

Figure 9

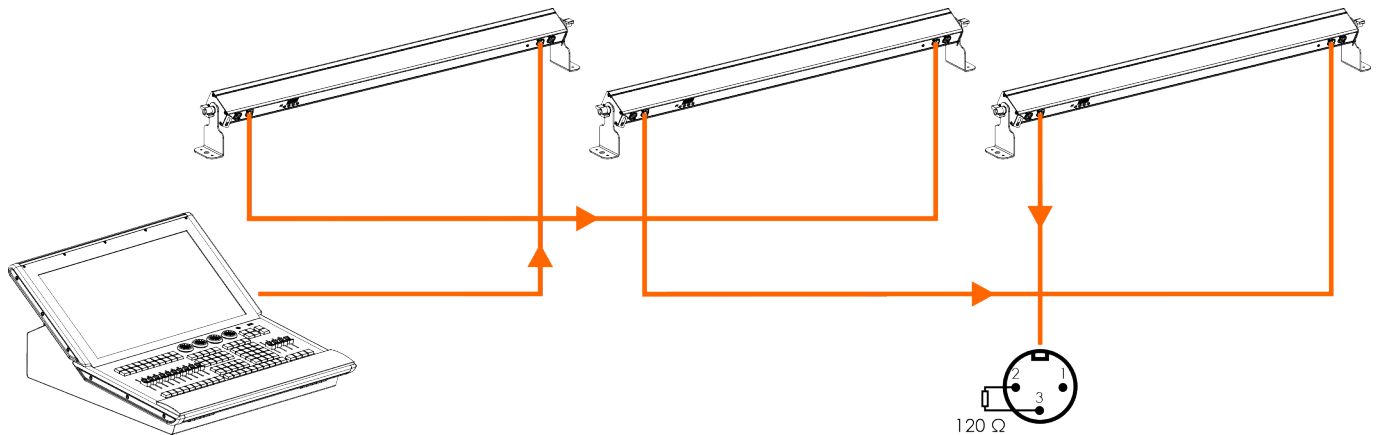

5.3.5. DMX Addressing

In a setup with multiple devices, make sure that you set the DMX starting address of each device correctly. The Sonus Bar 8 has 7 personalities: RGBW (4 channels), Pixel (32 channels), Basic (6 channels), Extended (34 channels), Auto (6 channels), Basic Auto (10 channels), Extended Auto (38 channels).

If you want to connect multiple devices on one data link and use them in 38-channel mode, for example, follow the steps below:

- 01) Set the starting address of the 1st device on the data link to 1 (001).
- 02) Set the starting address of the 2nd device on the data link to 39 (039), as $1 + 38 = 39$.
- 03) Set the starting address of the 3rd device on the data link to 77 (077), as $39 + 38 = 77$.
- 04) Continue assigning the starting addresses of the remaining devices by adding each time 38 to the previous number.

When addressing multiple devices on one data link, make sure that there are no overlapping channels. You cannot control devices individually if they have overlapping channels.

6. Operation

6.1. Safety Instructions for Operation



Attention

This device must be used only for the purposes it is designed for.

This device is intended for professional use as a stage light effect. It can be installed only indoors. This device is not suitable for households and for general lighting.

Any other use, not mentioned under intended use, is regarded as non-intended and incorrect use.



Attention

Power supply

Before connecting the device to the power supply, make sure that the current, voltage and frequency match the input voltage, current and frequency specified on the information label on the device.

6.2. Control Modes

The Sonus Bar 8 can be controlled as a stand-alone device, in master/slave mode and with a DMX controller.

The Sonus Bar 8 supports the following control modes:

- Stand-alone: Auto mode, program mode, color mode, sound-controlled mode, IR remote control
- Master/save: Auto mode, program mode, color mode, sound-controlled mode, IR remote control
- DMX-512: RGBW (4 channels), Pixel (32 channels), Basic (6 channels), Extended (34 channels), Auto (6 channels), Basic Auto (10 channels), Extended Auto (38 channels)

For more information about how to connect the devices, refer to Setup (see [5. Setup](#) on page 15).

To run the built-in programs in auto mode without a DMX controller:

- 01) Select one of the 3 auto programs in Auto Mode (see [6.6.1. Auto Mode](#) on page 21).
- 02) Adjust the parameters of the selected auto program.

To run the built-in programs in program mode without a DMX controller:

- 01) Select one of the 24 built-in programs in Program Mode (see [6.6.2. Program mode](#) on page 21).
- 02) Adjust the parameters of the selected built-in program.

To adjust the colors manually in color mode without a DMX controller:

- 01) Select one of the 4 colors in Color Mode (see [6.6.3. Color mode](#) on page 22).
- 02) Adjust the dimmer value of the selected color.

To run the sound programs in sound-controlled mode without a DMX controller:

- 01) Select one of the 21 sound programs in Sound Mode (see [6.6.4. Sound Mode](#) on page 22).
- 02) Adjust the parameters of the selected sound program.

To run the built-in programs in auto operation mode or in program mode, the sound-controlled mode or manually control the colors with the IR remote control (see [6.7. Remote Control](#) on page 26).

To operate the device with a DMX controller:

- 01) Select the DMX channel mode in the DMX Mode menu (see [6.6.7. DMX Mode](#) on page 25).
- 02) Set the DMX starting address of the device in the DMX Mode menu (see [6.6.7. DMX Mode](#) on page 25).
Refer to DMX Channels (see [6.8. DMX Channels](#) on page 30) for a complete overview of all DMX channels.

6.3. Control Panel

Figure 10

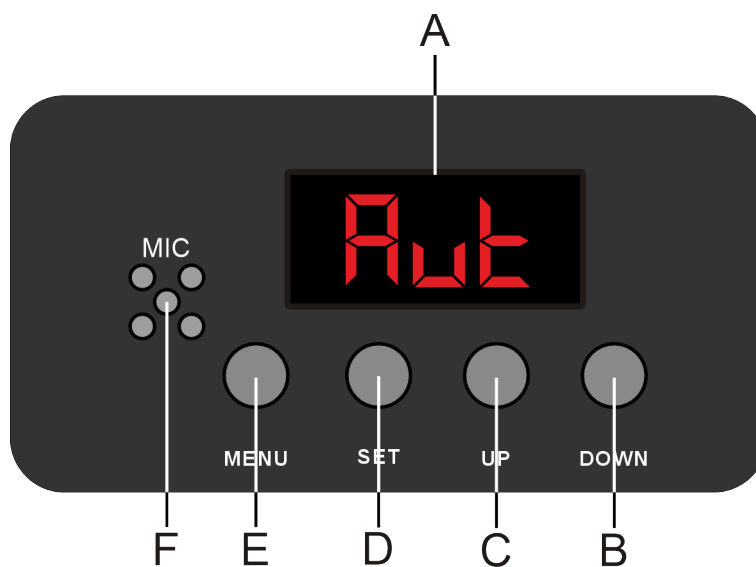

- A) 7-segment display
- B) DOWN button
- C) UP button
- D) SET button
- E) MENU button
- F) Built-in microphone

- Use the **MENU** button to exit the current submenu, to return to the Main Menu and to return to the start screen.
- Use the **UP/DOWN** buttons to navigate through the menus or to increase/decrease numeric values.
- Use the **SET** button to open the desired menu, to confirm your choice or to set the currently selected value.

6.4. Start-up

Upon start-up, the display shows a splash screen with the software version of the device.

v307

Immediately afterwards, the display shows the start screen. The start screen provides information about the current control mode of the device. For example:

AUTO

Press the **MENU** button to enter the main menu.

6.5. Menu Overview

Level 1	Level 2	Level 3
Auto (see 6.6.1. Auto Mode on page 21)	AU.01–AU.03	SP.01–SP.99–SP.FL FS.00–FS.99
Program (see 6.6.2. Program mode on page 21)	Pr.01	Co.01–Co.33 FS.00–FS.99
	Pr.02–Pr.24	SP.01–SP.99–SP.FL FS.00–FS.99
Color (see 6.6.3. Color mode on page 22)	r.000–r.255	
	g.000–g.255	
	b.000–b.255	
	u.000–u.255	
Sound (see 6.6.4. Sound Mode on page 22)	SO.01–SO.21	
	SU.00–SU.99–SU.FL	
Settings (see 6.6.5. Settings on page 23)	Cur	Cu-1–Cu-4
	bAck	ON–OFF
	PIdi	Nor–Inv
	FAIL	HOLd–OFF
	LOCK	ON–OFF
	FAc†	YES–NO
Info (see 6.6.6. Info on page 25)	Ver	v3.0.6
	Li-e	045h–00-
DMX Mode (see 6.6.7. DMX Mode on page 25)	d001–d511	4-ch
		32.ch
		6A.ch
		34.ch
		6b.ch
		10.ch 38.ch
Slave (see 6.6.8. Slave Mode on page 25)	YES–NO	

6.6. Main Menu Options

The main menu has the following options:

AUFO	Auto mode
Pro	Program mode
Colr	Color mode
Soud	Sound mode
SEt	Settings
Info	Info
d---	DMX mode
SLAu	Slave mode

01) Press the **MENU** button to navigate through the main menu.

02) Press the **SET** button to open the submenu.

6.6.1. Auto Mode

In this menu you can activate the auto programs, adjust the speed and add a strobe effect.



AU.01	Built-in program 3, built-in program 17–23
AU.02	Built-in program 2, built-in program 4–16, built-in program 24
AU.03	Built-in program 1–24

01) Press the **UP/DOWN** buttons to scroll through the 3 available options.

02) Press the **SET** button to confirm the selection and to open the submenu, where you can adjust the speed and add a strobe effect.

03) Press the **UP/DOWN** buttons to adjust the speed of the auto programs. The adjustment range is 01–99 and FL, from slow to fast. FL stands for 'full speed'.

04) Press the **UP/DOWN** buttons to add a strobe effect to the auto programs. The adjustment range is 00–99, from off to high frequency.

6.6.2. Program mode

In this menu you can select a preset color or a built-in program.

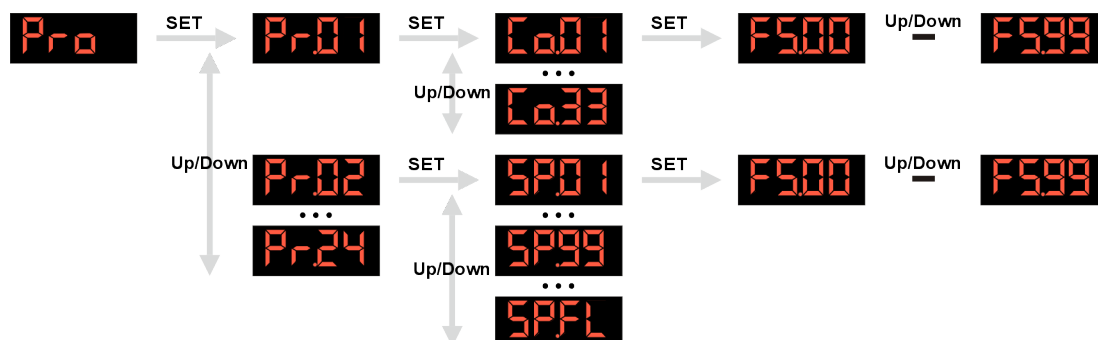

01) Press the **UP/DOWN** buttons to select one of the following options:

- Program 01: Select one of the 33 preset colors (see [6.6.2.1. Program 01](#))
- Programs 02–24: Select one of the 23 built-in programs (see [6.6.2.2. Program 02–24](#))

02) Press the **SET** button to confirm the selection.

6.6.2.1. Program 01

In this submenu you can select one of the 33 preset colors and add strobe effect.

- 01) Press the **UP/DOWN** buttons to select one of the 33 preset colors.
- 02) Press the **SET** button to confirm the selection and to open the submenu where you can add strobe effect.
- 03) Press the **UP/DOWN** buttons to add strobe effect. The adjustment range is 00–99, from off to high frequency.

6.6.2.2. Program 02–24

In this submenu you can select one of the 23 built-in programs, adjust the speed and add strobe effect.

- 01) Press the **UP/DOWN** buttons to select one of the 23 built-in programs.
- 02) Press the **SET** button to confirm the selection and open the submenu where you can adjust the speed.
- 03) Press the **UP/DOWN** buttons to set the speed of the selected built-in program. The adjustment range is 01–99 and FL, from slow to fast. FL stands for 'full speed'.
- 04) Press the **SET** button to confirm the selection and open the submenu where you can add strobe effect.
- 05) Press the **UP/DOWN** buttons to add strobe effect. The adjustment range is 00–99, from off to high frequency.

6.6.3. Color mode

In this menu you can adjust the color intensity for each LED individually and create custom colors.

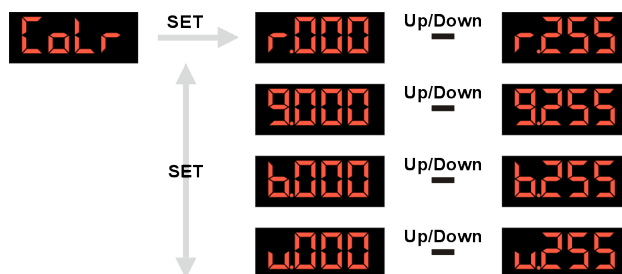

- 01) Press the **SET** button to select one of the 4 options: red, green, blue and white.
- 02) Press the **UP/DOWN** buttons to adjust the value. The adjustment range is 000–255, from low to high intensity.
- 03) Press the **SET** button to set the value and move to the next color.

6.6.4. Sound Mode

In this menu you can select a sound-controlled program and adjust the sensitivity of the built-in microphone.



- 01) Press the **UP/DOWN** buttons to select one of the 21 sound-controlled programs.
- 02) Press the **SET** button to confirm the selection and to open the submenu where you can adjust the sensitivity.
- 03) Press the **UP/DOWN** buttons to adjust the sensitivity of the built-in microphone. The adjustment range is 00–99 and FL, from off to high sensitivity. FL stands for 'maximum sensitivity'.

6.6.5. Settings

In this menu you can adjust the settings of the device.

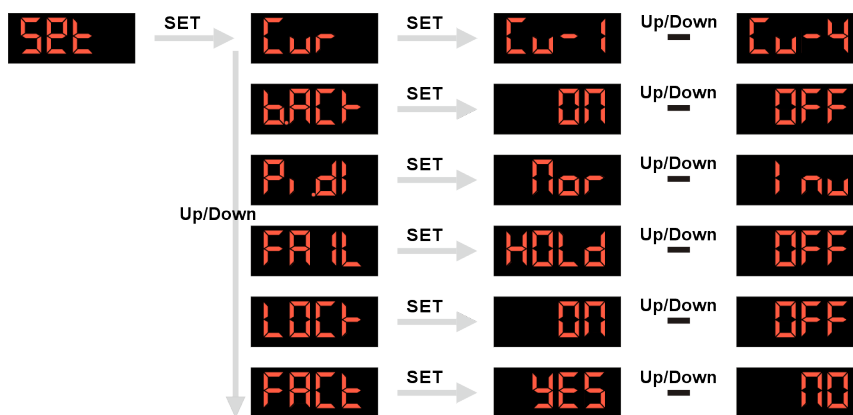

01) Press the **UP/DOWN** buttons to select one of the following 6 options:

- Dimmer Curve (see [6.6.5.1. Dimmer Curve](#))
- Backlight Time (see [6.6.5.2. Backlight Time](#))
- Pixel Direction (see [6.6.5.3. Pixel Direction](#))
- DMX Fail (see [6.6.5.4. DMX Fail](#))
- Display Lock (see [6.6.5.5. Display Lock](#))
- Default Factory Settings (see [6.6.5.6. Default Factory Settings](#))

02) Press the **SET** button to confirm the selection.

6.6.5.1. Dimmer Curve

In this submenu you can select the dimming curve.

01) Press the **UP/DOWN** buttons to select one of the 4 options:

- Curve 1: Linear
- Curve 2: Square Law
- Curve 3: Inverse Square Law
- Curve 4: S-Curve

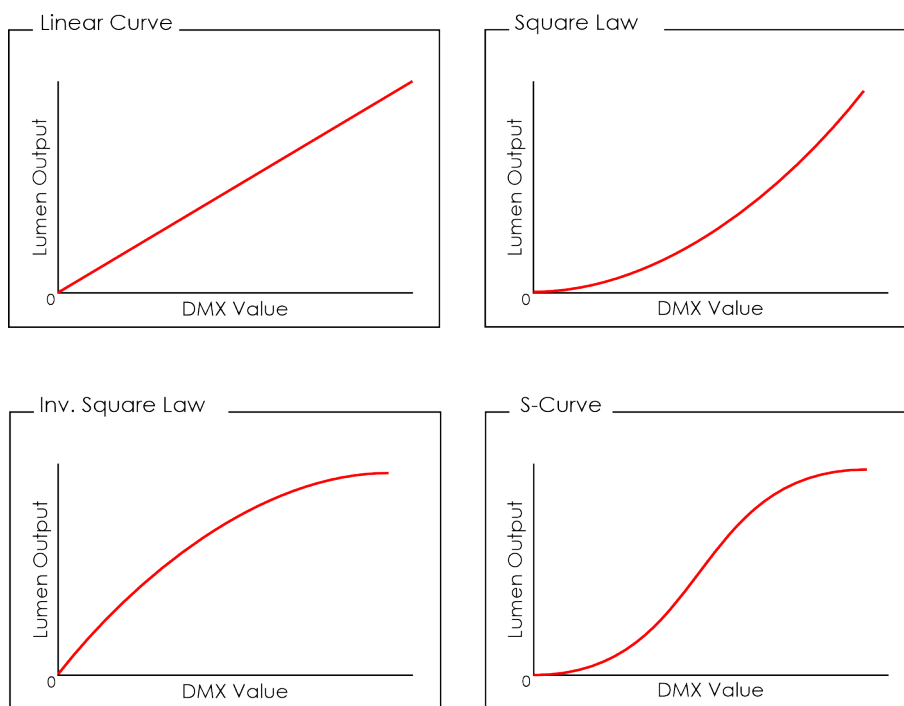

Figure 11

02) Press the **SET** button to confirm the selection.

6.6.5.2. Backlight Time

In this submenu you can adjust the behavior of the display.

01) Press the **UP/DOWN** buttons to select one of the 2 options:

- On: The backlight of the display remains on
- Off: The backlight of the display turns off after 15 s of inactivity and remains off

02) Press the **SET** button to confirm the selection.

6.6.5.3. Pixel Direction

In this submenu you can set the pixel direction of the device.

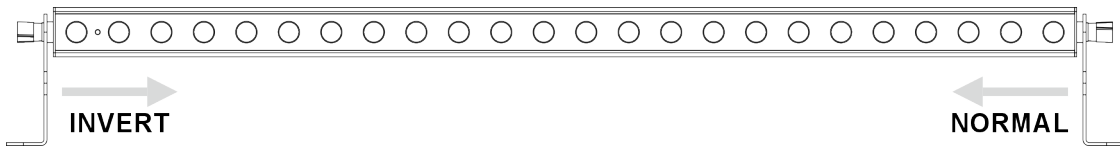

01) Press the **UP/DOWN** buttons to select one of the 2 options:

- Normal: Regular pixel direction
- Invert: Pixel direction is inverted

02) Press the **SET** button to confirm the selection.

6.6.5.4. DMX Fail

In this submenu you can determine the behavior of the device in case of a DMX failure.

01) Press the **UP/DOWN** buttons to select one of the 2 options:

- Off: The device will black out the light output
- Hold: The device will use the last properly received DMX signal which ensures uninterrupted performance

02) Press the **SET** button to confirm the selection.

6.6.5.5. Display Lock

In this submenu you can activate the display lock.

01) Press the **UP/DOWN** buttons to select one of the 2 options:

- On: The display lock is on. Do not press any button within 10 s of activating the lock. If you do so, the lock will be canceled. The selection remains but the display is not locked
- Off: The access to the main menu remains unlocked

02) Press the **SET** button to confirm the selection.

Note:

If the display is locked, you need to enter a password to access the main menu. The default password is pressing and holding the **MENU** button and the **SET** button for 3 seconds.

6.6.5.6. Default Factory Settings

In this submenu you can reset the settings of the device to the default factory settings.

01) Press the **UP/DOWN** buttons to select one of the 2 options:

- Yes: Reset to default factory settings
- No: Keep current settings, no factory reset

02) Press the **SET** button to confirm the selection.

6.6.6. Info

In this menu you can view the firmware version and the operating hours of the device.



- 01) Press the **UP/DOWN** buttons to select one of the 2 options:
 - Firmware Version: Shows the current firmware version
 - Fixture Hours: Shows the operating hours of the device
- 02) Press the **SET** button to confirm the selection.

6.6.7. DMX Mode

In this menu you can set the starting DMX address of the device.

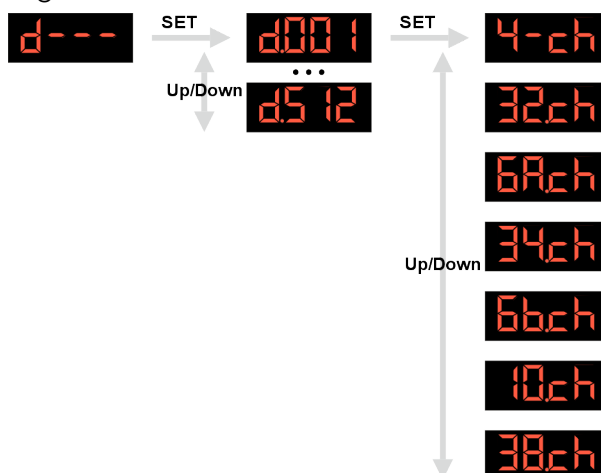

- 01) Press the **UP/DOWN** buttons to set the starting DMX address of the device. The selection range is d001–d512.
- 02) Press the **SET** button to confirm the selection and to open the submenu where you can set the channel mode of the device.
- 03) Press the **UP/DOWN** buttons to select the DMX channel mode of the device. There are 7 options available:
 - 4.ch: 4 CH (RGBW)
 - 32.ch: 32 CH (Pixel)
 - 6A.ch: 6 CH (Basic)
 - 34.ch: 34 CH (Extended)
 - 6b.ch: 6 CH (Auto)
 - 10.ch: 10 CH (Basic Auto)
 - 38.ch: 38 CH (Extended Auto)
- 04) Press the **SET** button to confirm the selection. For more information about DMX channels, refer to DMX Channels (see [6.8. DMX Channels](#) on page 30).

6.6.8. Slave Mode

In this menu you can set the device as a slave device in a master/slave setup.



- 01) Press the **UP/DOWN** buttons to select one of the 2 options:
 - Yes: The device is set as a slave and reacts the same as the master device
 - No: The device is set as the master device
- 02) Press the **SET** button to confirm the selection.

Note:

In a master/slave setup, make sure that only one device is set to master device and the remaining devices are set to slave devices. All slave devices will follow the master device.

6.7. Remote Control

The device can be operated with an IR remote control. The remote control is not included in the delivery. For more information about the IR remote control, refer to Optional Accessories (see [3.5. Optional Accessories](#) on page 11).



DANGER
Do not ingest battery, chemical burn hazard.

The remote control contains a coin cell battery. If the coin cell battery is swallowed, it can cause severe internal burns in just 2 hours and can lead to death.

6.7.1. Remote Control Mode

Point the IR remote control to the **IR sensor (02)** to control the device remotely (see [6.7.3. Remote Control Operation](#)). Make sure that you point the remote control in the range of the infrared sensor.

Note:

You can control several devices at the same time with the IR remote control.

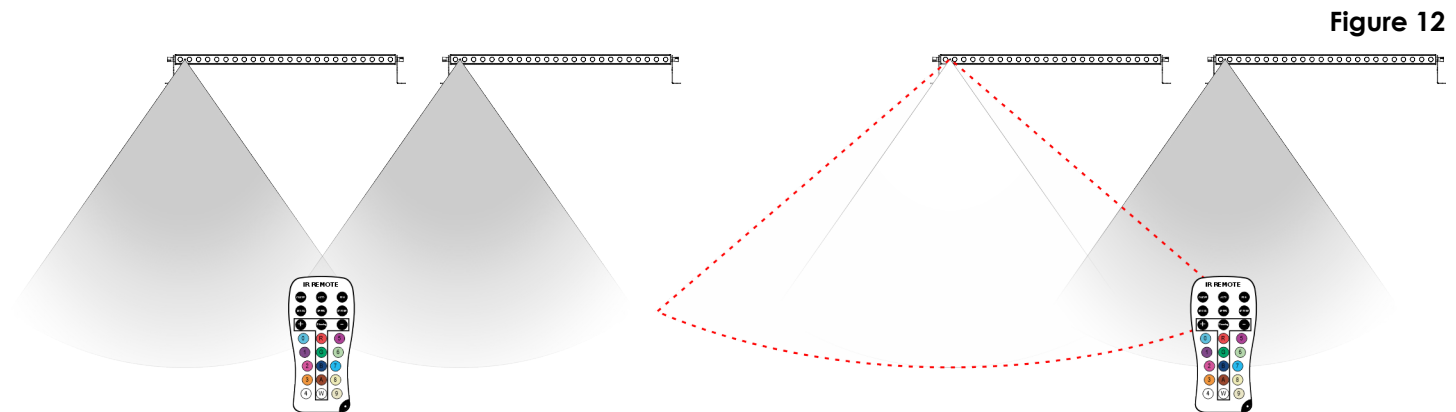

6.7.2. Functions of the Remote Control Buttons

The buttons of the remote control have the following functions:

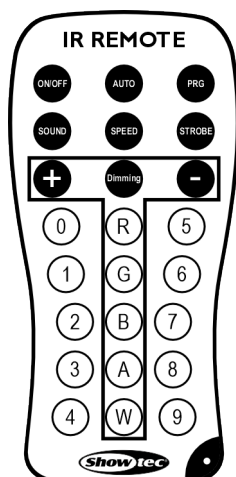

Button	Function	Description
	On/Off	Turns the LEDs on/off
	Auto	Auto mode 1–3
	Program	Program mode 1–24
	Sound	Sound mode 1–21
	Speed	Activates speed adjustment of the auto programs /built-in programs
	Strobe	Adds strobe effect
	Dimming	Activates Color mode
	Plus	Increase value
	Minus	Decrease value
	Red	Activates Red LEDs
	Green	Activates Green LEDs
	Blue	Activates Blue LEDs
	Amber	No Function
	White	Activates White LEDs
	Cyan	Activates color 14 (R000, G255, B255, W000)
	Purple	Activates color 22 (R 160; G 000; B 255; W 000)
	Purple/pink	Activates color 23 (R 255; G 000; B 255; W 000)
	Orange	Activates color 4 (R 255; G 050; B 000; W 000)
	Cool White	Activates color 33 (R 255; G 255; B 255; W 255)
	Pink	Activates color 25 (R 255; G 000; B 100; W 000)

6	Light Green	Activates color 8 (R 000; G 255; B 000; W 255)
7	Light Blue	Activates color 18 (R 000; G 000; B 255; W 100)
8	Light Yellow	Activates color 6 (R 255; G 255; B 000; W 000)
9	Warm White	Activates color 31 (R 075; G 075; B 000; W 255)

6.7.3. Remote Control Operation

When you control the device with the IR remote control, the following operation modes are possible:

- IR Auto mode (see [6.7.3.1. IR Auto Mode](#))
- IR Program mode (see [6.7.3.2. IR Program Mode](#))
- IR Sound mode (see [6.7.3.3. IR Sound Mode](#))
- IR Color mode (see [6.7.3.4. IR Color Mode](#))
- IR Preset colors (see [6.7.3.5. IR Preset Colors](#))

With the IR remote control you can also:

- add strobe effect
- reset the settings of the device to the default factory settings.

6.7.3.1. IR Auto Mode

- 01) Press the **AUTO** button to activate the IR auto mode.
- 02) Press the **AUTO** button multiple times to select one of the auto programs. There are 3 auto programs available.

To change the speed of the auto program:

- 01) Press the **SPEED** button to activate the speed function.
- 02) Press the **+** (**plus**) or **-** (**minus**) buttons to increase or decrease the speed of the selected auto program. You can view the adjustments on the **7-segment display (A)**. The adjustment range is 01–99 and FL, from slow to fast. FL stands for 'full speed'.

6.7.3.2. IR Program Mode

- 01) Press the **PRG** button to activate the IR program mode.
- 02) Press the **PRG** button multiple times to select one of the built-in programs. There are 24 built-in programs available.

To change the speed of the built-in program:

- 01) Press the **SPEED** button to activate the speed function.
- 02) Press the **+** (**plus**) or **-** (**minus**) buttons to increase or decrease the speed of the selected built-in program. You can view the adjustments on the **7-segment display (A)**. The adjustment range is 01–99 and FL, from slow to fast. FL stands for 'full speed'.

6.7.3.3. IR Sound Mode

- 01) Press the **SOUND** button to activate the IR sound mode.
- 02) Press the **+** (**plus**) or **-** (**minus**) buttons multiple times to select one of the sound-controlled programs. There are 21 sound-controlled programs available.

To change the sensitivity of the built-in microphone:

- 01) Press the **SOUND** button again to activate the sensitivity option.
- 02) Press the **+** (**plus**) or **-** (**minus**) buttons to increase or decrease the sensitivity. You can view the adjustments on the **7-segment display (A)**. The adjustment range is 00–95 and FL (in intervals of 5), from off to high sensitivity.

6.7.3.4. IR Color Mode

- 01) Press the **DIMMING** button to activate the IR color mode.
- 02) Press one of the **R/G/B/W** buttons to select the respective LEDs.
- 03) Press the **+** (**plus**) or **-** (**minus**) buttons to adjust the color intensity. You can view the adjustments on the **7-segment display (A)**. The adjustment range is 000–255 (in intervals of 5), from low to high intensity.

6.7.3.5. IR Preset Colors

Press the **0, 1, 2, 3, 4, 5, 6, 7, 8,** or **9** button to select one of the preset colors. For more information about the preset colors, refer to Functions of the Remote Control Buttons (see [6.7.2. Functions of the Remote Control Buttons](#) on page 27).

6.7.3.6. IR Strobe

You can add strobe effect:

- to IR Auto mode (see [6.7.3.1. IR Auto Mode](#))
- to IR Program mode (see [6.7.3.2. IR Program Mode](#))
- to IR Sound mode (see [6.7.3.3. IR Sound Mode](#))
- to IR Color mode (see [6.7.3.4. IR Color Mode](#))
- to IR Preset Colors (see [6.7.3.5. IR Preset Colors](#))

To add strobe effect:

- 01) Press the **STROBE** button.
- 02) Press the **+** (**plus**) or **-** (**minus**) buttons to increase or decrease the strobe frequency. You can view the adjustments on the **7-segment display (A)**. The adjustment range is 00–95 and 99 (in intervals of 5), from low to high frequency.
- 03) Press the **STROBE** button again to stop the strobe effect.

6.7.3.7. IR Factory Reset

You can reset the settings of the device to the default factory settings with the remote control.

Press and hold down the **ON/OFF** button and then press continuously buttons **9, 8** and **7** in this order.

6.8. DMX Channels

6.8.1. DMX Channels Overview

Function	RGBW 4 CH	Pixel 32 CH	Basic 6 CH	Extended 34 CH	Auto 6 CH	Basic Auto 10 CH	Extended Auto 38 CH
Dimmer			1	1	1	1	1
Strobe			2	2	2	2	2
Color presets					3	3	3
Program mode					4	4	4
Sound mode					5	5	5
Speed/sensitivity					6	6	6
Red section 1	1	1	3	3		7	7
Green section 1	2	2	4	4		8	8
Blue section 1	3	3	5	5		9	9
White section 1	4	4	6	6		10	10
Red section 2	1	5	3	7		7	11
Green section 2	2	6	4	8		8	12
Blue section 2	3	7	5	9		9	13
White section 2	4	8	6	10		10	14
Red section 3	1	9	3	11		7	15
Green section 3	2	10	4	12		8	16
Blue section 3	3	11	5	13		9	17
White section 3	4	12	6	14		10	18
Red section 4	1	13	3	15		7	19
Green section 4	2	14	4	16		8	20
Blue section 4	3	15	5	17		9	21
White section 4	4	16	6	18		10	22
Red section 5	1	17	3	19		7	23
Green section 5	2	18	4	20		8	24
Blue section 5	3	19	5	21		9	25
White section 5	4	20	6	22		10	26
Red section 6	1	21	3	23		7	27
Green section 6	2	22	4	24		8	28
Blue section 6	3	23	5	25		9	29
White section 6	4	24	6	26		10	30
Red section 7	1	25	3	27		7	31
Green section 7	2	26	4	28		8	32
Blue section 7	3	27	5	29		9	33
White section 7	4	28	6	30		10	34
Red section 8	1	29	3	31		7	35
Green section 8	2	30	4	32		8	36
Blue section 8	3	31	5	33		9	37
White section 8	4	32	6	34		10	38

6.8.2. RGBW (4 CH), Pixel (32 CH)

4 CH	32 CH	Function	Value	Setting
1	1	Red section 1	000-255	From low to high intensity (0-100 %)
2	2	Green section 1	000-255	From low to high intensity (0-100 %)
3	3	Blue section 1	000-255	From low to high intensity (0-100 %)
4	4	White section 1	000-255	From low to high intensity (0-100 %)
1	5	Red section 2	000-255	From low to high intensity (0-100 %)
2	6	Green section 2	000-255	From low to high intensity (0-100 %)
3	7	Blue section 2	000-255	From low to high intensity (0-100 %)
4	8	White section 2	000-255	From low to high intensity (0-100 %)
1	9	Red section 3	000-255	From low to high intensity (0-100 %)
2	10	Green section 3	000-255	From low to high intensity (0-100 %)
3	11	Blue section 3	000-255	From low to high intensity (0-100 %)
4	12	White section 3	000-255	From low to high intensity (0-100 %)
1	13	Red section 4	000-255	From low to high intensity (0-100 %)
2	14	Green section 4	000-255	From low to high intensity (0-100 %)
3	15	Blue section 4	000-255	From low to high intensity (0-100 %)
4	16	White section 4	000-255	From low to high intensity (0-100 %)
1	17	Red section 5	000-255	From low to high intensity (0-100 %)
2	18	Green section 5	000-255	From low to high intensity (0-100 %)
3	19	Blue section 5	000-255	From low to high intensity (0-100 %)
4	20	White section 5	000-255	From low to high intensity (0-100 %)
1	21	Red section 6	000-255	From low to high intensity (0-100 %)
2	22	Green section 6	000-255	From low to high intensity (0-100 %)
3	23	Blue section 6	000-255	From low to high intensity (0-100 %)
4	24	White section 6	000-255	From low to high intensity (0-100 %)
1	25	Red section 7	000-255	From low to high intensity (0-100 %)
2	26	Green section 7	000-255	From low to high intensity (0-100 %)
3	27	Blue section 7	000-255	From low to high intensity (0-100 %)
4	28	White section 7	000-255	From low to high intensity (0-100 %)
1	29	Red section 8	000-255	From low to high intensity (0-100 %)
2	30	Green section 8	000-255	From low to high intensity (0-100 %)
3	31	Blue section 8	000-255	From low to high intensity (0-100 %)
4	32	White section 8	000-255	From low to high intensity (0-100 %)

Figure 13

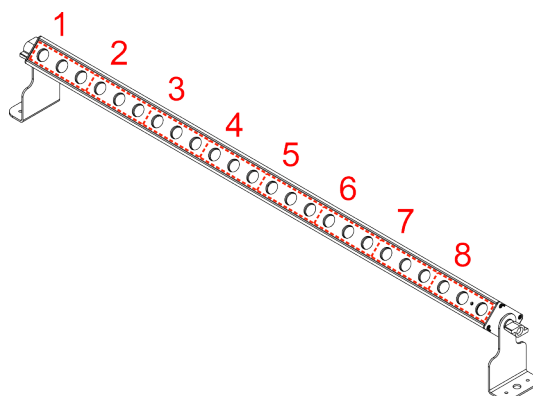

6.8.3. Basic (6 CH), Extended (34 CH), Auto (6 CH), Basic Auto (10 CH), Extended Auto (38 CH)

6CH	34CH	6CH	10CH	38CH	Function	Value	Setting
1	1	1	1	1	Dimmer	000–255	From low to high intensity (0–100 %)
2	2	2	2	2	Strobe	000–004	No function
						005–127	Linear strobe, from low to high frequency
						128–189	Random strobe for all LEDs, from low to high frequency
						190–255	Random strobe for sectional LEDs, from low to high frequency
3	3	3	3	Color presets	000–006	No function	
					007–013	Color 1 (R255, G000, B000, W000)	
					014–020	Color 2 (R255, G000, B000, W100)	
					021–027	Color 3 (R255, G000, B000, W200)	
					028–034	Color 4 (R255, G050, B000, W000)	
					035–041	Color 5 (R255, G150, B000, W000)	
					042–048	Color 6 (R255, G255, B000, W000)	
					049–055	Color 7 (R255, G255, B000, W075)	
					056–062	Color 8 (R000, G255, B000, W255)	
					063–069	Color 9 (R000, G255, B000, W150)	
					070–076	Color 10 (R000, G255, B000, W050)	
					077–083	Color 11 (R000, G255, B000, W000)	
					084–090	Color 12 (R000, G255, B050, W000)	
					091–097	Color 13 (R000, G255, B150, W000)	
					098–104	Color 14 (R000, G255, B255, W000)	
					105–111	Color 15 (R000, G255, B255, W075)	
					112–118	Color 16 (R000, G255, B255, W150)	
					119–125	Color 17 (R000, G100, B255, W255)	
					126–132	Color 18 (R000, G000, B255, W100)	
					133–139	Color 19 (R000, G000, B255, W050)	
					140–146	Color 20 (R000, G000, B255, W000)	
					147–153	Color 21 (R075, G000, B255, W000)	
					154–160	Color 22 (R160, G000, B255, W000)	
					161–167	Color 23 (R255, G000, B255, W000)	
					168–174	Color 24 (R255, G000, B175, W000)	
					175–181	Color 25 (R255, G000, B100, W000)	
					182–188	Color 26 (R255, G000, B100, W050)	
					189–195	Color 27 (R255, G000, B025, W050)	
					196–202	Color 28 (R255, G000, B025, W025)	
					203–209	Color 29 (R255, G000, B025, W000)	
					210–216	Color 30 (R000, G000, B000, W255)	
					217–223	Color 31 (R075, G075, B000, W255)	
					224–230	Color 32 (R000, G000, B100, W255)	
231–255	Color 33 (R255, G255, B255, W255)						
4	4	4	4	Color program	000–015	No function	
					016–025	Jump 1	
					026–035	Jump 2	
					036–045	Jump 3	
					046–055	Jump 4	

6CH	34CH	6CH	10CH	38CH	Function	Value	Setting
						056-065	Jump 5
						066-075	Jump 6
						076-085	Jump 7
						086-095	Jump 8
						096-105	Jump 9
						106-115	Jump 10
						116-125	Jump 11
						126-135	Jump 12
						136-145	Fade 1
						146-155	Fade 2
						156-165	Fade 3
						166-175	Fade 4
						176-185	Fade 5
						186-195	Fade 6
						196-205	Fade 7
						206-215	Fade 8
						216-225	Fade 9
						226-235	Fade 10
						236-245	Fade 11
						246-255	No function
						000-003	No function
						004-015	Sound Mode 1
						016-027	Sound Mode 2
						028-039	Sound Mode 3
						040-051	Sound Mode 4
						052-063	Sound Mode 5
						064-075	Sound Mode 6
						076-087	Sound Mode 7
						088-099	Sound Mode 8
						100-111	Sound Mode 9
		5	5	5	Sound mode	112-123	Sound Mode 10
						124-135	Sound Mode 11
						136-147	Sound Mode 12
						148-159	Sound Mode 13
						160-171	Sound Mode 14
						172-183	Sound Mode 15
						184-195	Sound Mode 16
						196-207	Sound Mode 17
						208-219	Sound Mode 18
						220-231	Sound Mode 19
						232-243	Sound Mode 20
						244-255	Sound Mode 21
		6	6	6	Speed/sensitivity	000-255	From slow to fast (Program mode) / Sensitivity (Sound mode)
3	3		7	7	Red section 1	000-255	From low to high intensity (0-100 %)
4	4		8	8	Green section 1	000-255	From low to high intensity (0-100 %)
5	5		9	9	Blue section 1	000-255	From low to high intensity (0-100 %)

6CH	34CH	6CH	10CH	38CH	Function	Value	Setting
6	6		10	10	White section 1	000-255	From low to high intensity (0-100 %)
3	7		7	11	Red section 2	000-255	From low to high intensity (0-100 %)
4	8		8	12	Green section 2	000-255	From low to high intensity (0-100 %)
5	9		9	13	Blue section 2	000-255	From low to high intensity (0-100 %)
6	10		10	14	White section 2	000-255	From low to high intensity (0-100 %)
3	11		7	15	Red section 3	000-255	From low to high intensity (0-100 %)
4	12		8	16	Green section 3	000-255	From low to high intensity (0-100 %)
5	13		9	17	Blue section 3	000-255	From low to high intensity (0-100 %)
6	14		10	18	White section 3	000-255	From low to high intensity (0-100 %)
3	15		7	19	Red section 4	000-255	From low to high intensity (0-100 %)
4	16		8	20	Green section 4	000-255	From low to high intensity (0-100 %)
5	17		9	21	Blue section 4	000-255	From low to high intensity (0-100 %)
6	18		10	22	White section 4	000-255	From low to high intensity (0-100 %)
3	19		7	23	Red section 5	000-255	From low to high intensity (0-100 %)
4	20		8	24	Green section 5	000-255	From low to high intensity (0-100 %)
5	21		9	25	Blue section 5	000-255	From low to high intensity (0-100 %)
6	22		10	26	White section 5	000-255	From low to high intensity (0-100 %)
3	23		7	27	Red section 6	000-255	From low to high intensity (0-100 %)
4	24		8	28	Green section 6	000-255	From low to high intensity (0-100 %)
5	25		9	29	Blue section 6	000-255	From low to high intensity (0-100 %)
6	26		10	30	White section 6	000-255	From low to high intensity (0-100 %)
3	27		7	31	Red section 7	000-255	From low to high intensity (0-100 %)
4	28		8	32	Green section 7	000-255	From low to high intensity (0-100 %)
5	29		9	33	Blue section 7	000-255	From low to high intensity (0-100 %)
6	30		10	34	White section 7	000-255	From low to high intensity (0-100 %)
3	31		7	35	Red section 8	000-255	From low to high intensity (0-100 %)
4	32		8	36	Green section 8	000-255	From low to high intensity (0-100 %)
5	33		9	37	Blue section 8	000-255	From low to high intensity (0-100 %)
6	34		10	38	White section 8	000-255	From low to high intensity (0-100 %)

6.9. RDM Information

This device supports RDM (see [6.9.2. Supported RDM PIDs \(Parameter IDs\)](#)).

6.9.1. RDM Details

- Responder ID: 29B4:0FAXXXXX
- Manufacturer's ID: Showtec (Highlite International B.V.)
- Manufacturer Label: Showtec
- Model Description: Sonus Bar 8
- Model ID: 250 (0FA hexadecimal)
- Device Label: Sonus Bar 8

Note:

An RDM responder ID consists of 3 parts:

- 1st part – 4 digits – Manufacturer's ID
- 2nd part – 3 digits – Model ID
- 3rd part – 5 digits – Unique ID

The RDM responder IDs of all products of Highlite International start with the same 4 digits. The first 7 digits of the RDM responder ID for each model are the same. The last 5 digits are different for each device.

6.9.2. Supported RDM PIDs (Parameter IDs)

RDM Parameter ID	Value	Required	GET	SET
SUPPORTED_PARAMETERS	0x0050	*	*	
DEVICE_MODEL_DESCRIPTION	0x0080		*	
MANUFACTURER_LABEL	0x0081		*	
DEVICE_LABEL	0x0082		*	*
FACTORY_DEFAULTS	0x0090		*	*
DMX_PERSONALITY	0x00E0		*	*
DMX_PERSONALITY_DESCRIPTION	0x00E1		*	
DMX_START_ADDRESS	0x00F0	*	*	*
RESET_DEVICE	0x1001			*

7. Troubleshooting

This troubleshooting guide contains solutions to problems which can be carried out by an ordinary person. The device does not contain user-serviceable parts.

Unauthorized modifications to the device will render the warranty void. Such modifications may result in injuries and material damage.

Refer servicing to instructed or skilled persons. Contact your Highlite International dealer in case the solution is not described in the table.

Problem	Probable cause(s)	Solution
The device does not function at all	No power to the device	<ul style="list-style-type: none"> Make sure that the device is connected to power supply and the cables are plugged in
	The internal fuse is blown	<ul style="list-style-type: none"> Disconnect the device and contact your Highlite International dealer
The device responds erratically	The factory settings of the device are changed	<ul style="list-style-type: none"> Reset the parameters of the device to the default factory settings (see 6.6.5.6. Default Factory Settings on page 24)
The device does not respond to DMX control	The controller is not connected	<ul style="list-style-type: none"> Connect the controller
	The signal is reversed. The 3-pin DMX OUT of the controller does not match the DMX IN of the device	<ul style="list-style-type: none"> Install a phase-reversing cable between the controller and the device
	The controller is defective	<ul style="list-style-type: none"> Try using another controller
The device responds erratically to DMX control	Connections are defective	<ul style="list-style-type: none"> Examine connections and cables. Correct defective connections. Repair or replace damaged cables
	The data link is not terminated with a 120 Ω termination plug	<ul style="list-style-type: none"> Insert a termination plug in the DMX OUT connector of the last device on the link
	Incorrect addressing	<ul style="list-style-type: none"> Make sure that the address settings are correct
	In case of a setup with multiple devices, one of the devices is defective and disturbs data transmission on the link	<ul style="list-style-type: none"> To find out the defective device, bypass one device at a time until normal operation is restored
No light or LEDs cut out intermittently	LEDs are damaged	<ul style="list-style-type: none"> Disconnect the device and contact your Highlite International dealer
	The input power parameters of the device do not match the local AC voltage and frequency	<ul style="list-style-type: none"> Disconnect the device. Make sure that the local current, voltage and frequency match the input voltage, current and frequency specified on the information label on the device
The device does not function with the IR remote control	The IR remote control is not compatible with the device	<ul style="list-style-type: none"> Make sure that you use an IR remote control that is compatible with the device (see 3.5. Optional Accessories on page 11)
	The battery of the IR remote is depleted	<ul style="list-style-type: none"> Replace the battery of the IR remote
	The remote control is outside of the range of the infrared sensor	<ul style="list-style-type: none"> Walk closer to the device or change the angle at which you point the remote control to the device (see 6.7. Remote Control on page 26)

8. Maintenance

8.1. Safety Instructions for Maintenance



DANGER
Electric shock caused by dangerous voltage inside

Disconnect power supply before servicing or cleaning.

8.2. Preventive Maintenance



Attention
Before each use, examine the device visually for any defects.

Make sure that:

- All screws used for installing the device or parts of the device are tightly fastened and are not corroded.
- The safety devices are not damaged.
- There are no deformations on housings, fixings and installation points.
- The lens is not cracked or damaged.
- The power cables are not damaged and do not show any material fatigue.

8.2.1. Basic Cleaning Instructions

The external lens of the device must be cleaned periodically in order to optimize the light output. The cleaning schedule depends on the conditions at the site where the device is installed. When smoke or fog machines are used at the site, the device will need more frequent cleaning. On the other hand, if the device is installed in well-ventilated area, it will need less frequent cleaning. To establish a cleaning schedule, examine the device at regular intervals during the first 100 hours of operation.

To clean the device, follow the steps below:

- 01) Disconnect the device from the electrical power supply.
- 02) Allow the device to cool down for at least 15 minutes.
- 03) Remove the dust collected on the external surface with dry compressed air and a soft brush.
- 04) Clean the lens with a damp cloth. Use a mild detergent solution.
- 05) Dry the lens carefully with a lint-free cloth.
- 06) Clean the DMX and other connections with a damp cloth.



Attention

- Do not immerse the device in liquid.
- Do not use alcohol or solvents.
- Make sure that the connections are fully dry before connecting the device to the power supply and to other devices.

8.3. Corrective Maintenance

The device does not contain user-serviceable parts. Do not open the device and do not modify the device.

Refer repairs and servicing to instructed or skilled persons. Contact your Highlite International dealer for more information.

9. Deinstallation, Transportation and Storage

9.1. Instructions for Deinstallation



WARNING

Incorrect deinstallation can cause serious injuries and damage of property.

- Let the device cool down before dismounting.
- Disconnect power supply before deinstallation.
- Always observe the national and site-specific regulations during deinstallation and derigging of the device.
- Wear personal protective equipment in compliance with the national and site-specific regulations.

9.2. Instructions for Transportation

- Use the original packaging to transport the device, if possible.
- Always observe the handling instructions printed on the outer carton box, for example: "Handle with care", "This side up", "Fragile".

9.3. Storage

- Clean the device before storing.
- Store the device in the original packaging, if possible.

10. Disposal

Correct disposal of this product



Waste Electrical and Electronic Equipment

This symbol on the product, its packaging or documents indicates that the product shall not be treated as household waste. Dispose of this product by handing it to the respective collection point for recycling of electrical and electronic equipment. This is to avoid environmental damage or personal injury due to uncontrolled waste disposal. For more detailed information about recycling of this product contact the local authorities or the authorized dealer.

11. Approval



Check the respective product page on the website of Highlite International (www.highlite.com) for an available declaration of conformity.

